

# MAXIGEAR

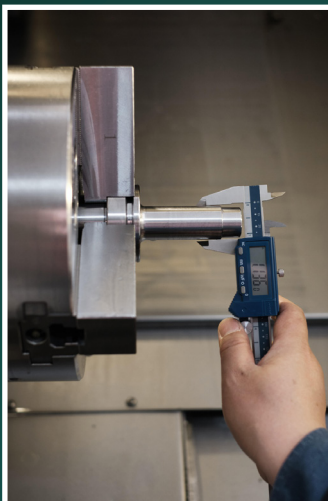

WWW.PRETOOLING.COM.AU

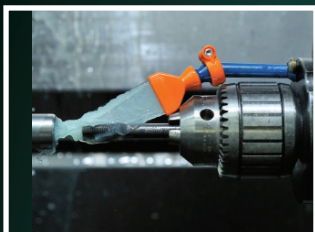



## MARKING TOOLS AND TEMPERATURE INDICATORS

**ABOUT:** LA-CO Industries, Inc. is a family owned global manufacturing company specializing in the manufacturing of industrial hand-held markers and temperature indicators. Since 1934, LA-CO have taken pride in the design and manufacturing of high quality, performance-based products for our customers' unique applications.

Like any other tool, markers and temperature indication products are specialized to help professionals do the jobs they need to do. As the industry's leader in these categories, LA-CO continuously invest in research and development to meet the requirements of a constantly changing and advancing marketplace. Through careful product evaluation and analysis, our chemists create proprietary formulas, which are designed to meet the needs of our customers.

### MARKAL

Markal® is the global leader in high-performance, hand-held industrial marking products. LA-CO's North American and European manufacturing locations, supporting the hardworking contractors that build the world's great bridges, ships, automobiles, homes, office towers, power plants, railways and many other engineering marvels with Markal products.

### PRO-LINE HIGH PERFORMANCE MARKERS

PRO-LINE® HP is a liquid paint marker developed for superior marking performance on oily and greasy surfaces. The high performance paint penetrates through oils and greases to dry quickly and leave a bold, permanent mark that is wear, weather and fade-resistant.

#### PRO-LINE HP



- **HIGH PERFORMANCE MARKERS**
- High performance paint penetrates through oils and greases to dry quickly and leave a bold, permanent mark
- Unique paint formula resists spreading and dries quickly through oily surfaces to leave precise, permanent marks
- Marking range: -46°C to 66°C

Colour	Part No
White	MK96960
Yellow	MK96961
Red	MK96962
Black	MK96963
Orange	MK96964
Blue	MK96965
Green	MK96966
Pink	MK96973
Replacement Nibs	MK96908



Mark Size 3mm

#### PRO LINE FINE & PRO LINE MICRO



- **FINE TIP FOR PRECISION MARKING**
- Liquid paint marker for fine line marking
- High-strength, lightweight barrel designed for industrial-grade use
- Small tip sizes provide highly-visible, sharp lines for greater mark identification.
- Marking range: -18°C to 66°C

Colour	Type	Part No
White	Fine	MK96871
Yellow	Fine	MK96872
Black	Fine	MK96873
White	Micro	MK96888
Yellow	Micro	MK96889
Black	Micro	MK96890



Pro Line Fine:  
Mark Size 1.5mm

Pro Line Micro:  
Mark Size 1mm

## HIGH QUALITY INDUSTRIAL MARKPAINT MARKERS

### MARKPAINT

Markpaint is a high quality permanent paint marker. Paint offers an opaque and glossy mark on most light or dark surfaces. Perfect for indoor and outdoor use, the paint is weatherproof. Marks do not fade, for long-lasting results. This market does not contain xylene or toluene protecting users health.

- Low odor
- Made in Germany
- Smudge-proof
- Waterproof
- Marking Temp range -16C° TO 50C°
- Light and durable barrel w/ acrylic bullet nib 2-4mm

Colour	Part No
White	MK97520
Yellow	MK97521
Red	MK97522
Black	MK97523
Blue	MK97524
Green	MK97525
Orange	MK97526
Pink	MK97527
Purple	MK97528



INDIVIDUAL MARKERS



#### PACK OF 3 MARKERS ON HANG CARDS

MK975Y3	3 X YELLOW
MK975W3	3 X WHITE
MK975B3	3 X BLACK



MK199015  
CUSTOM COLOURS X 32  
COUNTER DISPLAY

#### Industry Uses:

- Automotive & Other transportations
- Automotive Assembly
- Industrial Manufacturing
- Metal Fabrication
- Construction
- Welding
- Textile Industry
- Rail Industry
- Shipping Supply
- Military

#### Surface Uses:

- Steel, Iron, Non-ferrous Metals
- Aluminum
- Rubber/ Tyres
- Glass
- Plastic
- Cardboard
- Ceramic
- Cloth & Fabric (Textiles)
- Pipes, Tubes, & Plates
- Tiles, Concrete & Stone



## PRO LINE WP



- **WET SURFACE MARKING**
- Specially formulated paint resists running or spreading on wet or damp surfaces to leave permanent, highly-visible marks
- Marking range: -46°C to 66°C

Colour	Part No
Yellow	MK96931
Black	MK96933



Mark Size 3mm

## PRO MAX



- **EXTRA LARGE MARKING**
- Extra large tip ideal for signage or safety marking where immediate identification is required
- Valve-actuated tip releases paint on-demand for smooth, continuous use
- Marking range: -18°C to 66°C

Colour	Part No
Yellow	MK90900
Black	MK90903



Mark Size up to 14mm

## PRO WASH D



- **REMOVABLE LIQUID PAINT MARKER**
- Fast drying paint easily removes leaving surfaces free of mark ghosting or paint residue.
- Pro-Wash D marks can be removed with detergent solutions that have a pH level of 10 or above.
- Marking range: -18°C to 66°C

Colour	Part No
Yellow	MK97011
Black	MK97013



Mark Size 3mm

## STYLMARK TUBE MARKER

Markal® Stylmark® is a metal-ball tip marker for marking most surfaces. The aluminum squeeze tube and thick paint makes it suitable for rough, vertical and overhead surfaces with excellent adhesion on oily and wet surfaces. Xylene-free paint reduces user health risks.



- **METAL-BALL TIP PAINT MARKER FOR MULTIPLE SURFACES**
- Aluminum squeeze tube and thick paint makes it suitable for rough, vertical and overhead surfaces with excellent adhesion on oily and wet surfaces.
- Marking range -20°C to 70°C

Colour	Part No
White	MK96652
Yellow	MK96653
Black	MK96655



Mark Size 3mm

## SECURITY CHECK PAINT MARKER

Security Check Paint Marker is perfect for indicating tampering or loosening of bolts or parts, Markal Security Check paint provides an easy-to-read visual indication. The non-drip formula easily applies across bolt threads and cracks when loosened.



- Paint marks crack for visual indication of loosening or tampering of bolts and parts
- Each tube packed with extended plastic tip
- Dry to touch: 15 minutes
- Full Cure: 4 days
- Larger volume tube holds 70% more paint than leading competitor
- Marking range: -4°F to 158°F, (20°C to 70°C)
- Mark temperature resistance: 392°F. (200°C)

Colour	Part No
Orange	MK96674



Mark Size 3mm

## QUIK STIK

Quik Stik® is a smooth-marking solid paint crayon that dries quickly to leave a bold, permanent mark on most surfaces. The durable plastic twist-up holder prevents breakage. Keep hands, clothing, and toolboxes clean with the industry's largest twist-up solid paint marker.

### QUIK STIK TWIST UP



- **FAST-DRYING SOLID PAINT IN TWIST-UP HOLDER**
- Marks dry in 5 to 7 minutes
- Contains 20% more paint than other brands
- Marks on virtually any surface: wet, smooth, rough, or hot
- Airtight, self-storing cap keeps the marker clean and fresh between uses
- Weather- and UV-resistant paint for long-lasting mark
- Marking range: -18°C to 200°C

Colour	Part No
Red	MK61049
Black	MK61050
White	MK61051
Blue	MK61070

- **AVAILABLE IN HI-VISIBILITY YELLOW**

Colour	Part No
Fluoro Yellow	MK61041



### QUIK STIK MINI



- **MINI MARKER FOR FINE LINE MARKING**
- Ideal for finer line marking on smooth or rough surfaces.
- Fast-drying, vibrant paint marks dry in 5 to 7 minutes
- Marks on virtually any surface: wet, smooth, rough, or hot
- Weather- and UV-resistant paint for long-lasting mark
- Marking range: -18°C to 200°C

Colour	Part No
White	MK61126
Yellow	MK61127
Red	MK61128
Black	MK61129



## PAINTSTIK

As Markal's most versatile and economic marker, the original B® Paintstik® solid paint marker combines the durability of paint in the convenience of a crayon. The real paint formula has superior marking performance on oily, icy, wet, dry or cold surfaces and is weather and UV-resistant. This Paintstik® works on rough, rusty, smooth, or dirty surfaces.

### PAINTSTIK B



- **MULTI-PURPOSE PERMANENT SOLID PAINT CRAYON**
- Real paint for long-lasting, highly visible marks
- Solid paint marker eliminates replacement tips, sharpening or priming, increasing productivity
- Weather- and UV-resistant for long-lasting marks
- Marking range: -46°C to 66°C

Colour	Part No
White	MK80220
Yellow	MK80221
Red	MK80222
Black	MK80223
Blue	MK80225



Mark Size 17mm

### LUMBER CRAYON 500 CLAY BASED LUMBER CRAYON

**NEW**



Markal Lumber Crayon #500 is a harder, clay-based crayon for longer marking life and is suitable for marking in hot climates. The bold, bright marks are weather and UV-resistant.

available in **YELLOW** only  
Part No  
MK80321



## PAINTSTIK CONT.

As Markal's most versatile and economic marker, the original B® Paintstik® solid paint marker combines the durability of paint in the convenience of a crayon. The real paint formula has superior marking performance on oily, icy, wet, dry or cold surfaces and is weather and UV-resistant. This Paintstik® works on rough, rusty, smooth, or dirty surfaces.

### PAINTSTIK B-L BLEED THRU



Designed to bleed through solvent- or oil-based primers or painted surfaces, the B-L Paintstik is ideal for structural steel parts or layout work where marks are required to show through a covering coat of paint or primer.

Colour	Part No
Blue	MK80725



Mark Size 17mm

### PAINTSTIK H - HOT SURFACE MARKER

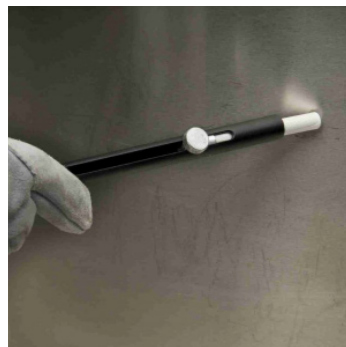

- **THE INDUSTRY ORIGINAL** Writes on hot castings, forgings, coils, billets, plates and other hot metal surfaces
- Lasts up to 3X longer than the writing life of hot chalk
- Fast-drying marks are permanent and will not run, char, flow, discolor, peel or crack
- Forgings and parts can be immediately dipped into cold water baths without damaging the marks
- Marking range: 107°C to 593°C

Colour	Part No
Yellow	MK81021
Black	MK81023

EXTRA LONG METAL HOLDER TO SUIT

Length	Part No
28mm	MK85700



Box Quantity 144  
Mark Size 9.5mm

### PAINTSTIK N - WHITE MARKER



- **MARKS WILL NOT SHOW THROUGH TOP COAT OF PAINT OR PRIMER**
- Ideal for ship building or other metal fabrication
- Solid paint formula designed for marking on wet, dry, oily, rusty, icy, smooth, or rough surfaces
- Marking range: -18°C to 66°C

Colour	Part No
White	MK82120



Mark Size 17mm

### PAINTSTIK WS - 3/8 WATER SOLUBLE



- **REMOVABLE SOLID PAINT CRAYON**
- The fine line marks are easily wiped away with water and will not ghost.
- Ideal for temporary marking on non-porous surfaces
- Marking range: -18°C to 66°C

Colour	Part No
Yellow	MK82421



Mark Size 9.5mm

### PAINTSTIK P - GALVANISER'S MARKER



- **SUPERIOR MARKING ON ROUGH, RUSTY, OILY, OR SMOOTH SURFACES**
- Designed for use in pickling baths or galvanizing operations.
- Marks remove in pickling baths to allow excellent adhesion for zinc coating compared to liquid paint markers
- Solid paint crayon makes wide, bold marks for instant identification

Colour	Part No
White	MK83420



Mark Size 17mm

## DURA INK - PERMANENT INK MARKERS

### DURA-INK 5



- **PERMANENT MARKER WITH EXTENDED MICRO TIP**
- For precision marking needs and is ideal to use through drill holes, mounting brackets, or in any hard to reach areas.
- Industrial-strength ink is smear- and water-resistant for longer lasting marks

Colour	Part No
Black	MK96520



Mark Size 1mm

### DURA-INK 20



- **RETRACTABLE MARKER WITH FINE BULLET TIP**
- Marker features a one-handed, push-button for easy opening and closing.
- Fast-drying ink formula completely washes off all non-porous surfaces
- High-visibility marks are water and detergent removable without ghosting or residue

Colour	Part No
Black	MK96575
Red	MK96576



Mark Size 3mm

### DURA-INK 55



- **MEDIUM CHISEL TIP**
- Permanent ink marker with medium chisel tip to produce both fine and broad permanent marks.
- Industrial-strength ink is smear- and water-resistant for longer lasting marks

Colour	Part No:
Red	MK96528
Black	MK96529
Blue	MK96530
Green	MK96531



Mark Size  
1.5mm / 4.5mm

### DURA-INK 200



- **LARGE BROAD CHISEL TIP**
- Can produce both extra-large or medium-sized marks
- Industrial grade tip will not spread or mush
- Jumbo ink supply for greater marking mileage

Colour	Part No:
Red	MK96916
Black	MK96917



Mark Size  
9.5mm / 16mm

### DURA-INK WASH AWAY



- **TEMPORARY INK MARKER**
- Quickly and completely washes off non-porous surfaces with water or cleaning solutions without leaving a residue or ghosting on the surface.
- Engineered specially for temporary marking applications, the highly-visible ink formula dries quickly to avoid smudging or lost marks and is ideal for use on most metals and glass.

Colour	Part No:
Blue	MK96302



Mark Size  
3mm / 8mm

## TRADES MARKER - GREASE HOLDER WITH 5 REFILLS



- Trades Marker has the marking versatility of a paper-wrapped grease pencil combined with simple push-button advance that helps reduce cost and waste.
- This refillable, all-surface marker leaves a wear-resistant mark and is safe for all surfaces.
- Suitable for Smooth, rough, rusty, or dirty surfaces
- Holder maximizes complete use of marker
- Marks are rub- and weather-resistant, leaving a bold, permanent mark
- Contains 5 coloured refills:
- **Orange** **White** **Red** **Yellow** **Black**



PART NO: MK96000

### 12 PCE REFILL PACK

Colour	Part No
<b>Orange</b>	MK96247
<b>White</b>	MK96240
<b>Red</b>	MK96242
<b>Yellow</b>	MK96241
<b>Black</b>	MK96243



## TRADES MARKER - WATER SOLUBLE 12 PCE - YELLOW



- Trades Marker WS is a refillable, all-surface marker that leaves a removable mark and is safe for all surfaces.
- Marks can be wiped away easily with water. Ideal for quality control and temporary marking needs
- Suitable for Smooth, rough, rusty, or dirty surfaces
- Holder maximizes complete use of marker

### TRADES MARKER KIT

Colour	Part No
<b>Yellow</b>	MK961910

### 12 PCE REFILL PACK

Colour	Part No
<b>Yellow</b>	MK96181



## MARKAL PRO HOLDER



- Markal Pro Holder uses a long needle-nose tip to mark in hard-to-reach spots.
- The all-metal and refillable construction, built-in sharpener, and one-click advance provide years of reliability and ease-of-use.

### 6 PCE REFILL PACK

Colour	Part No
<b>Silver Streak Pro</b>	MK96271
<b>Red Riter Pro</b>	MK96272
<b>Graphite, Red &amp; Yellow</b>	MK96276

PRO HOLDER  
PART NO: MK96270



## SILVER-STREAK METAL MARKER

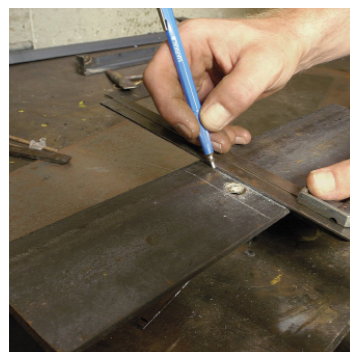

- Highly visible marks illuminate when cutting or welding
- Superior to soapstone in markability and durability; will not rub, burn or blow off surface
- Marks on oily, wet or rusty metals, and will not scratch or abrade surfaces
- Durable, mechanical holder prevents stick breakage and features a convenient, built-in sharpener and pocket clip for easy storage.
- **MARKER WITH 1 LEAD SILVER REFILL**  
MK96006
- **MARKER WITH 6 LEAD SILVER REFILLS**  
MK96107
- **SILVER STREAK REFILL PACK OF 6**  
MK96007



## WELDERS PENCIL - SILVER STREAK & RED RITER

Welders pencils for metal layout and fabrication



- **RED TO SUIT ALUMINUM OR OTHER BRIGHT METALS, SILVER SUITS DARKER SURFACES**
- Reflective lead illuminates when cutting or welding for improved visibility
- The soapstone alternative: marks resist torch flames; will not rub, burn or blow off
- Durable marks will not scratch or abrade metal surfaces

<b>Box of 12</b>	<b>Part No</b>
<b>Red Riter</b>	MK96100
<b>Silver Streak</b>	MK96101

<b>Pack of 3</b>	<b>Part No</b>
<b>2 x Silver 1 x Red</b>	MK22219
<b>3 x Silver</b>	MK22220



3 PCE HANG PACKS



BOX QUANTITY 12

## VALVE ACTION PAINT MARKER

The UV-visible Valve Action makes an invisible paint mark that glows bright blue when viewed with a UV or black light, making it ideal for security, quality control, tamper-proofing, and anti-counterfeiting processes. The permanent invisible liquid paint dries quickly to provide long-lasting, weather- and wear-resistant marks.



- **UV INVISIBLE MARKER**
- Ideal for security, theft-prevention and quality control.
- Fast-drying formula to reduce smearing.
- Dura-Nib medium bullet tip resists wear and tear for a longer marking life
- Marking range: -46°C to 66°C

<b>Colour</b>	<b>Part No</b>
<b>Ultraviolet Blue</b>	MK97054



Mark Size 3mm

## TEMPIL

Tempil® is an industrial leader in advanced and accurate temperature indication technologies. From protecting NASA's Space Shuttle Orbiter to measuring critical temperatures of life saving drugs and devices, engineers and professionals rely on the accuracy of Tempil for the most vital applications.

## TEMPILSTIK - TEMPERATURE INDICATING STICK

Fast, accurate surface temperature indicator.

Providing accuracy, confidence and compliance for over 80 years, Tempilstik is the original temperature-indicating stick with the best combination of precision and convenience for surface temperature measurement. Specially engineered for accurate temperature indication in pre-heating, interpass and post-weld heat treating applications, Tempilstik is the industry's leading choice for use in the most critical jobs.

Stick instantly melts at designated temperature for easy and immediate visual inspection

Accurate to within +/- 1% of Fahrenheit and +/- 3% Celsius rated

Part No:	Temperature Reading °
TS28006	66 C / 150 F
TS28301	50 C / 122 F
TS28310	100 C / 212 F
TS28318	150 C / 302 F
TS28327	200 C / 392 F
TS28336	250 C / 482 F
TS28600	20 Piece Temperature Indicator Kit





**HEAVY DUTY 3 POINT PUNCHES**

- Produce holes in sheet metal up to 3mm (10 SWG) in mild steel, or 2mm (14 SWG) in Stainless Steel
- 3 Point Punches have a hexagon head bolt to facilitate use with a ratchet and socket.
- Thrust races are also available to reduce friction & make for easier use on thicker materials

Sheet Metal Punches Produce accurate Burr Free Holes in steel and brass.

Part No.	Hole Diameter
QMM10HD	10mm
QMM11HD	11mm
QMM12.7HD	12.7mm
QMM14HD	14mm
QMM15.2HD	15.2mm
QMM15HD	15mm
QMM16HD	16mm
QMM17.5	17.5mm
QMM18.6HD	18.6mm
QMM19HD	19mm
QMM20.4HD	20.4mm
QMM20HD	20mm
QMM21HD	21mm
QMM22.5HD	22.5mm
QMM24HD	24mm
QMM25HD	25mm
QMM27.5HD	27.5mm
QMM28.3HD	28.3mm
QMM29HD	29mm
QMM30HD	30mm
QMM31HD	31mm
QMM32HD	32mm

Part No.	Hole Diameter
QMM32.5HD	32.5mm
QMM34HD	34mm
QMM35HD	35mm
QMM37.5HD	37.5mm
QMM37HD	37mm
QMM40HD	40mm
QMM45HD	45mm
QMM47HD	47mm
QMM48HD	48mm
QMM50HD	50mm
QMM51HD	51mm
QMM52HD	52mm
QMM54HD	54mm
QMM55HD	55mm
QMM60HD	60mm
QMM64HD	64mm
QMM65HD	65mm
QMM70HD	70mm
QMM75HD	75mm
QMM76.5HD	76.5mm
QMM80HD	80mm
Square	
QMMS19	19mm
QMMS25.4	25.4mm

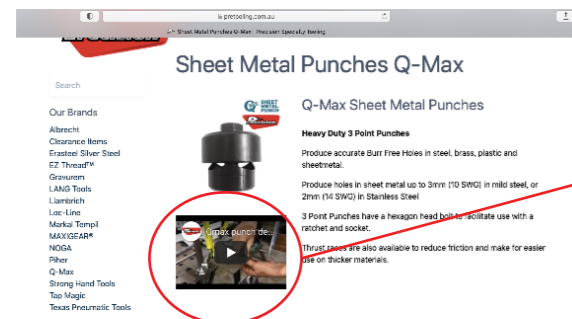

**A Demonstration video on how to use a QMAX Sheet Metal Punch is displayed on our website.**

**WAD PUNCHES**

For cutting accurate holes in cardboard, rubber, leather and other soft materials Alloy tool steel, Precision Machine Ground Hardened & Tempered, Powder coated finish



Part No.	Size
WP02	2mm 1/16 inch
WP03	3mm 1/8 inch
WP04	4mm 5/32 inch
WP05	5mm 3/16 inch
WP06	6mm 7/32 inch
WP07	7mm 1/4 inch
WP08	8mm 5/16 inch
WP09	9mm 11/32 inch
WP10	10mm 3/8 inch
WP11	11mm 7/16 inch
WP12	12mm 15/32 inch
WP13	13mm 1/2 inch
WP14	14mm 9/16 inch
WP15	15mm 19/32 inch
WP16	16mm 5/8 inch
WP17	17mm 21/32 inch
WP18	18mm 11/16 inch
WP19	19mm 3/4 inch
WP20	20mm 25/32 inch
WP21	21mm 13/16 inch

Part No.	Size
WP22	22mm 7/8 inch
WP23	23mm 29/32 inch
WP24	24mm 15/16 inch
WP25	25mm 1 inch
WP26	26mm 1-1/32 inch
WP28	28mm 1-3/32 inch
WP29	29mm 1-1/8 inch
WP30	30mm 1-3/16 inch
WP31	31mm 1-7/32 inch
WP32	32mm 1-1/4 inch
WP33	33mm 1-9/32 inch
WP35	35mm 1-3/8 inch
WP38	38mm 1-1/2 inch
WP41	41mm 1-5/8 inch
WP42	42mm 1-21/32 inch
WP44	44mm 1-3/4 inch
WP47	47mm 1-7/8 inch
WP48	48mm 1-29/32 inch
WP50	50mm 2 inch
WP53	53mm 2-11/128 inch

Part No.	Size
WP55	55mm 2-3/16 inch
WP56	56mm 2-13/64 inch
WP57	57mm 2-1/4 inch
WP60W	60mm 2-3/8 inch
WP63	63mm 2-1/2 inch
WP69	69mm 2-23/32 inch
WP70	70mm 2-3/4 inch
WP73	73mm 2-7/8 inch
WP75	75mm 3 inch
WP82	82mm 3-1/4 inch
WP100	100mm 4 inch

**NEW**

**INTERCHANGEABLE WAD PUNCH SET**

SET 3mm - 20mm  
(3, 4, 6, 8, 10, 12, 14, 16, 18, 20 + holder)

For cutting washers, sealing rings made of foam, cardboard, leather, fibers, plastics, lead etc.

**PART NO. WPIK0320**



**Other sizes in the range 1mm - 120mm available on special buy in terms. Conform to DIN 7200**



# MAXIGEAR

## RATCHETING WRENCHES - COMBINATION THE NEW PREMIUM IN RATCHETING WRENCHES.

Deeper Gear Teeth enables stronger torque

72 Teeth ratchet for a 5° swing arc to turn a fastener

Small head profile and professional plating for corrosion resistance.

Meets or exceeds DIN and A.N.S.I. standards

Guaranteed to be free from manufacturers and material defects for the life of the tool during normal use.

Size	MAXIGEAR No.	Equivalent Size	Overall Length
6mm	MGC4006	9106	136mm
7mm	MGC4007	9107	136mm
8mm	MGC4008	9108	136mm
9mm	MGC4009	9109	143mm
10mm	MGC4010	9110	160mm
11mm	MGC4011	9111	168mm
12mm	MGC4012	9112	174mm
13mm	MGC4013	9113	180mm
14mm	MGC4014	9114	193mm
15mm	MGC4015	9115	200mm
16mm	MGC4016	9116	216mm
17mm	MGC4017	9117	233mm
18mm	MGC4018	9118	239mm
19mm	MGC4019	9119	250mm
20mm	MGC4020	9120	285mm
21mm	MGC4021	9121	285mm
22mm	MGC4022	9122	285mm
24mm	MGC4024	9124	325mm
25mm	MGC4025	9125	325mm
27mm	MGC4027	9127	359mm
30mm	MGC4030	9130	425mm
32mm	MGC4032	9132	425mm
36mm	MGC4036	9136	425mm
Size	MAXIGEAR No.	Equivalent Size	Overall Length
1/4"	MGC4052	9008	136mm
5/16"	MGC4054	9010	136mm
11/32"	MGC4055	9011	143mm
3/8"	MGC4056	9012	160mm
7/16"	MGC4058	9014	168mm
1/2"	MGC4060	9016	180mm
9/16"	MGC4062	9018	193mm
5/8"	MGC4064	9020	216mm
3/4"	MGC4068	9024	250mm
13/16"	MGC4070	9026	286mm
7/8"	MGC4072	9028	286mm
15/16"	MGC4074	9030	325mm
1"	MGC4076	9032	325mm
1-1/16"	MGC4077	9034	359mm
1-1/8"	MGC4078	9036	425mm



MAXIGEAR Set No.	Equivalent Sizes	Contents
MGC4080 12 piece	9412	8, 9, 10, 11, 12, 13, 14, 15, 16, 17, 18, 19mm
MGC4090 16 piece		8, 9, 10, 11, 12, 13, 14, 15, 16, 17, 18, 19, 20, 21, 22, 24mm
MGC4086 12 piece	9312	1/4, 5/16, 3/8, 7/16, 1/2, 9/16, 5/8, 3/4, 13/16, 7/8, 15/16, 1inch

# MAXIGEAR

## RATCHETING WRENCHES - REVERSIBLE

Compact reversible switch enables moving from forward to reverse without removing the tool from the fastener

15° offset head for knuckle clearance and safe operation above the workpiece

Size	MAXIGEAR No.	Equivalent Size	Overall Length
6mm	MGR6006	-	124mm
7mm	MGR6007		140mm
8mm	MGR6008	9608	140mm
9mm	MGR6009	9609	142mm
10mm	MGR6010	9610	158mm
11mm	MGR6011	9611	167mm
12mm	MGR6012	9612	173mm
13mm	MGR6013	9613	179mm
14mm	MGR6014	9614	189mm
15mm	MGR6015	9615	199mm
16mm	MGR6016	9616	215mm
17mm	MGR6017	9617	232mm
18mm	MGR6018	9618	238mm
19mm	MGR6019	9619	247mm
20mm	MGR6020	-	285mm
21mm	MGR6021	9621	285mm
22mm	MGR6022	9622	285mm
24mm	MGR6024	9624	325mm
Size	MAXIGEAR No.	Equivalent Size	Overall Length
1/4"	MGR6052	-	124mm
5/16"	MGR6054	9525	135mm
3/8"	MGR6056	9526	158mm
7/16"	MGR6058	9527	167mm
1/2"	MGR6060	9528	179mm
9/16"	MGR6062	9529	189mm
5/8"	MGR6064	9530	215mm
11/16"	MGR6066	9531	232mm
3/4"	MGR6068	9532	247mm
13/16"	MGR6070	9534	285mm
7/8"	MGR6072	9538	285mm
15/16"	MGR6074	9539	325mm
1"	MGR6076	9540	325mm



MAXIGEAR Set No.	Equivalent Sizes	Contents
MGR6080 12 piece	9620	8, 9, 10, 11, 12, 13, 14, 15, 16, 17, 18, 19mm
MGR6090 16 piece	9602	8, 9, 10, 11, 12, 13, 14, 15, 16, 17, 18, 19, 20, 21, 22, 24mm
MGR6087 13 piece	9509	1/4, 5/16, 3/8, 7/16, 1/2, 9/16, 5/8, 11/16, 3/4, 13/16, 7/8, 15/16, 1inch

### MAXIGEAR TOOL ROLLS

MAXIGEAR Set No.	Contents
MGTR8	8 piece
MGTR13	13 piece
MGTRS12	12 piece Stubby

# MAXIGEAR

## RATCHETING WRENCHES - FLEX HEAD

Flex Head tilts 180° at any interval with continuous head tension

Flex Head permits access to fasteners in difficult to access areas



Size	MAXIGEAR No.	Equivalent Size	Overall Length
8mm	MGF5008	9908	136mm
9mm	MGF5009	9909	143mm
10mm	MGF5010	9910	160mm
11mm	MGF5011	9911	168mm
12mm	MGF5012	9912	174mm
13mm	MGF5013	9913	180mm
14mm	MGF5014	9914	193mm
15mm	MGF5015	9915	200mm
16mm	MGF5016	9916	216mm
17mm	MGF5017	9917	233mm
18mm	MGF5018	9918	239mm
19mm	MGF5019	9919	250mm
20mm	MGF5020	-	285mm
21mm	MGF5021	9921	285mm
22mm	MGF5022	9922	285mm
24mm	MGF5024	9924	325mm
25mm	MGF5025	9925	325mm
MAXIGEAR	Equivalent	Overall	
Size	No.	Size	Length
1/4"	MGF5052	-	136mm
5/16"	MGF5054	9705	136mm
3/8"	MGF5056	9706	160mm
7/16"	MGF5058	9707	168mm
1/2"	MGF5060	9708	180mm
9/16"	MGF5062	9709	193mm
5/8"	MGF5064	9710	216mm
11/16"	MGF5066	9711	233mm
3/4"	MGF5068	9712	250mm
13/16"	MGF5070	9713	285mm
7/8"	MGF5072	9714	285mm
15/16"	MGF5074	9715	325mm
1"	MGF5076	9716	325mm



MAXIGEAR Set No.	Equivalent Sizes	Contents
MGF5080	9901	8, 9, 10, 11, 12, 13, 12 piece
MGF5087	9702	1/4, 5/16, 3/8, 7/16, 1/2, 9/16, 5/8, 11/16, 3/4, 13/16, 7/8, 15/16, 1inch, 13 piece

# MAXIGEAR

## STUBBY COMBINATION RATCHETING WRENCHES

The same features as the Combination MAXIGEAR in a compact design for use in tight spaces



Size	MAXIGEAR No.	Equivalent Size	Overall Length
6mm	MGS7006	-	88mm
8mm	MGS7008	-	88mm
10mm	MGS7010	9510	96mm
11mm	MGS7011	9511	100mm
12mm	MGS7012	9512	104mm
13mm	MGS7013	9513	108mm
14mm	MGS7014	9514	114mm
15mm	MGS7015	9515	118mm
16mm	MGS7016	9516	122mm
17mm	MGS7017	9517	128mm
18mm	MGS7018	9518	132mm
19mm	MGS7019	9519	138mm
MAXIGEAR	Equivalent	Overall	
Size	No.	Size	Length
3/8"	MGS7056	-	96mm
7/16"	MGS7058	-	100mm
1/2"	MGS7060	-	108mm
9/16"	MGS7062	-	118mm
5/8"	MGS7064	-	122mm
11/16"	MGS7066	-	128mm
23/4"	MGS7068	-	138mm



MAXIGEAR Set No.	Equivalent Sizes	Contents
MGS7080	9520	8, 10, 11, 12, 13, 14, 11 piece
MGS7089	9507	[10 piece] 15, 16, 17, 18, 19mm, 7 piece 3/8, 7/16, 1/2, 9/16, 5/8, 11/16, 3/4 inch

## MAXIGEAR® MULTI ANGLE HEAD & EXTENDING BAR - ANSI TESTED

Indexing head: Pivots through 180°, adjusted by simply pressing a button on the head to move the bar into multiple locking positions allowing for close precision work in shifting, sliding, parting & aligning.

Extending variable body length: Press the locking button on the main body handle to increase / decrease the desired length required, when compacted can be stored in a tool chest

Strength is built in; Maxigear Pry Bars are manufactured & rigorously tested to ANSI standards.

Part No	Description
MGPB1315	Pry Bar Indexing Head & Extendable 315mm - 450mm
MGPB1620	Pry Bar Indexing Head & Extendable 620mm - 900mm
MGPB1863	Pry Bar Indexing Head & Extendable 860mm - 1350mm

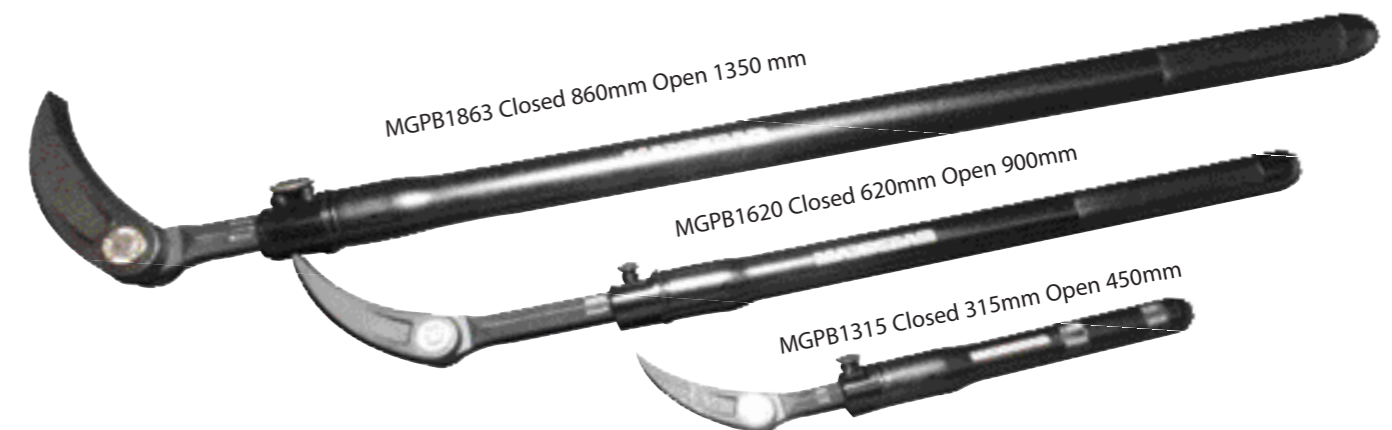

## HEX KEYS

**THE ONLY HEX KEY WHICH CAN DRIVE 100% ROUND HEX DRIVE SCREWS PATENTED DESIGN**  
Insert or extract cap head screw without damaged as well as being able to remove worn or damaged heads utilising the same patented key set.

**9PC METRIC HEX KEY / EXTRACTOR SET**  
Long Arm - 1.5mm /10mm **MGHK2050**

**9PC SAE HEX KEY / EXTRACTOR SET**  
Long Arm - 1/16" - 3/8" **MGHK2075**



## LINE WRENCHES

Unique patented ratcheting system

Can be opened to slip over the brake pipe & closed to fit around the brake pipe nut completely

Unique geometry that allows to work on rounded & worn nuts, and even a tighter grip on rusted nuts

Applications : brake piping, hydraulic & pneumatic connections, power assisted steering, A/C and fuel lines.



Part No.	Contents
PST-70010	8 x 9, 10 x 11, 12 x 13, 14 x 15mm
PST-70070	5/16 x 3/8, 7/16 x 1/2, 9/16 x 5/8, 11/16 x 3/4
PST-70124	24mm flex-hd combination
PST-70132	32mm flex-hd combination

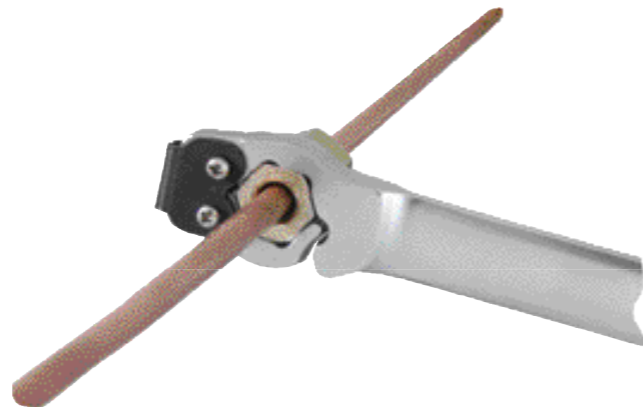

## MAXIGEAR TWIN FULCRUM PLIERS

**DIFFICULT TO REACH AREAS? NOT ANY MORE**

Ground flush finish produces a narrow but strong profile whilst maintaining maximum reach with Twin Fulcrum Pliers allowing the jaws to be fully open in a single handed operation holding the twin-dipped comfort handles maximising grip via the serrated jaw tips, available in Straight & 45° Jaw styles with an overall length of 340mm.

Part No.	Style
MGM5800	Straight
MGM5500	TWIN PACK

Twin Pack contains 1x MGM5800 straight & 1xMGM5900 45°



## FLEXIBLE SOCKET SET

3/8" Sq Dr. 10pc Metric 6 Point  
Sizes 10,11,12,13,14,15,16,17,18,19mm  
Supplied on Socket Rail

**Part No. MGM8086**



## MAGNETIC SOCKET RAILS

Easy glide 360° rotating studs make easy work of making your socket selection.

Magnetic rail makes for convenient storage.  
10 turnable Square Drive Studs.

**Part No:** **MGM7038**      **Size** **3/8"**



## VERSA-DRIVE ADAPTERS

Versa-Drive adapters allow users to easily switch between sockets and hex bits without having to switch adapters.

Product comes in 2 1/4" Hex shank adapters

- 3/8" Drive adapter with 1/4" hex for bits
- 1/2" Drive adapter with 5/16" hex for bits

Unlike current 1/4" hex-to-square socket adapters, the Versa-Drive incorporates the hex drive into the square socket head itself allowing users to go back and forth between bit and socket without ever removing the adapter from the tool. Used with 1/4" hex drive tools like impact drivers or 1/4" drill chucks the Versa-Drive is a real time saver in a variety of applications. Enables users to easily switch between sockets and hex bits. Impact rated for use in 1/4" cordless and pneumatic impact drivers For torques up to 112.22 M/Kg or 900kg

**Part No.: CV00490**



# MAXIGEAR

## DIAMOND WET & DRY CUT HOLESAWS / CORE DRILLS

Effective cutting of Ceramic, Glass, Masonry, Granite, Gypsum. Use with an Electric or Battery Powered Drill for sizes up to 12mm. Sizes 14mm and over use with an Angle Grinder with M14 x 2 mount. Fast and Efficient Cutting of some of the most difficult materials.

Part No.	Diameter	Mount	Cut
HDW70006	6mm	1/4 Hex	Wet
HDW70008	8mm	1/4 Hex	Wet
HDW70010	10mm	1/4 Hex	Wet
HDW70012	12mm	1/4 Hex	Wet
HDW75000	4 Piece Set	1/4 Hex	Wet
HDW70014	14mm	1/4 Hex	Wet
HDD70020	20mm	M14 x 2	Dry
HDD70022	22mm	M14 x 2	Dry
HDD70035	35mm	M14 x 2	Dry
HDD70040	40mm	M14 x 2	Dry
HDD70045	45mm	M14 x 2	Dry
HDD70053	53mm	M14 x 2	Dry
HDD70068	68mm	M14 x 2	Dry

## TUNGSTEN CARBIDE COATED HOLESAWS

For the easy drilling of large diameters in masonry, tiles, bricks, gypsum plaster, for wall sockets, pipe lines, cable ducts & discharge pipes.

Part No.	Diameter
HTC80001	Arbor with Drill
HTC80033	33mm
HTC80043	43mm
HTC80053	53mm
HTC80067	67mm
HTC80073	73mm
HTC80083	83mm
HTC80103	103mm
HTC85000	6 Piece Set
33mm, 53mm, 67mm, 73mm, 83mm & Arbor with Drill	

## ENGINEERS CHALK

Suitable for Welding and fabrication for marking clear, dustless lines on metals, steel, stone and masonry. Made from first Grade mineral, and the whiteness of 93%. Dust free, high visibility. Won't run, char, discolour, peel, or crack when welding.

Part No.	Description	Box Qty
EC10x10BX	10mm x 10mm x 80mm sticks	50 sticks
EC10x10CT	10mm x 10mm x 80mm sticks	1000 sticks
EC10x5BX	10mm x 5mm x 75mm sticks	100 sticks
EC10x5CT	10mm x 5mm x 75mm sticks	2000 sticks



# MAXIGEAR



## MAGNETIC IMPACT SOCKETS

Features Deep Impact Socket and Standard Impact Socket. Magnetic for a secure hold on any fastener. Deep Series consists of a spring loaded magnet that retracts into the socket for extended bolt application.

Part No:	Drive	Size
MGID1410	1/4DR	10mm
MGID1412	1/4DR	12mm
MGID1413	1/4DR	13mm
MGID1414	1/4DR	14mm
MGID3810	3/8DR	10mm
MGID3812	3/8DR	12mm
MGID3813	3/8DR	13mm
MGID3814	3/8DR	14mm
MGID1210	1/2DR	10mm
MGID1212	1/2DR	12mm
MGID1213	1/2DR	13mm
MGID1214	1/2DR	14mm



## MAGNETIC IMPACT SOCKET 12 PIECE SETS

Set No:	Drive	Size
MGIS1400	1/4 Drive Standard	4 - 15mm
MGID1400	1/4 Drive Deep	4 - 15mm
MGIS3800	3/8 Drive Standard	8 - 19mm
MGID3800	3/8 Drive Deep	8 - 19mm
MGIS1200	1/2 Drive Standard	10 - 21mm
MGID1200	1/2 Drive Deep	10 - 21mm

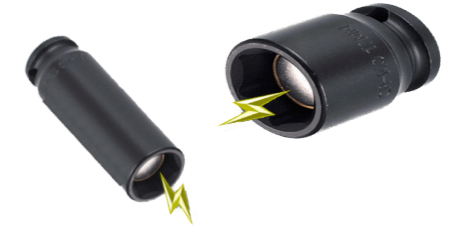

## DOUBLE FLARING TOOL

This 45 degree DOUBLE FLARING TOOL set is designed to withstand the high pressure. It includes 5 double flare adapters, drop forged compressor yoke. Includes bar assembly with size capacity- 4.15, 5, 6, 8 and 10mm.

**PST-70153 METRIC**



## IN LINE FLARING TOOL

This low profile design In Line Flaring Tool enables automotive technicians to flare copper or soft steel tubing in tight spaces using a ratchet or wrench.

The patented new flaring tool design makes perfect single or double flares easily. The double clamp and hex body keeps tube from slipping, keeps flares centered, and makes the job of flaring easier. Superior to bar type flaring tools. For flaring 3/16" and 4.75mm tubing.

**Part No. PST-70161**





**PORTABLE BEARING PACKER**

The Portable Bearing Packer works on bearings up to 89mm [3-1/2"] outside diameter. The grease stays in the tool cavity, not on your hands. To pack a bearing, place the bearing on the piston Press down on the cap until the old grease is forced out and the new grease shows on top of the bearing  
**Part No. PST-72775**



**SCREW EXTRACTOR KIT - 5 PIECE**

- Forged alloy steel, this tapered style extractor can be used to extract broken studs, screws, pipe and pipe fittings.
- Has gradual taper and long flutes.

**Part No. PST-65000**



**HEAVY DUTY OIL FILTER STRAP WRENCH**

- This deluxe wrench adjusts quickly to any spin-on filter.
  - Features 3/8-in. and 1/2-in. forged driver and heavy duty strap for high torque requirements.
- Handles filters up to 9-in. (228mm) especially high torque requirements on truck and tractors

**Part No. PST-27800**

**TOOL GRIPPER WRENCH RACKS**

Manufactured from flexible rubber as opposed to stiff plastic. The rubber flexes around the wrench to hold it in place at virtually any angle. Very durable and won't crack or split like plastic versions. Manufactured in the USA.



Part No.	Description
PST-5040E	4 pce wrench rack - RED
PST-5080E	7 pce wrench rack - RED
PST-5015E	12 pce wrench rack -RED
PST-5013E	13 pce wrench rack - RED
PST-5088E	15 pce wrench rack - FLURO
PST-5188R	15 pce reverse wrench rack -RED
PST-5072E	7 pce wrench rack Stubby - RED
PST - 5082HV	15 pce wrench rack - FLURO
PST-5500E	10 pce plier organiser - RED



Stubby Wrench Rack

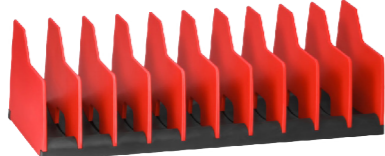

Pliers Organiser

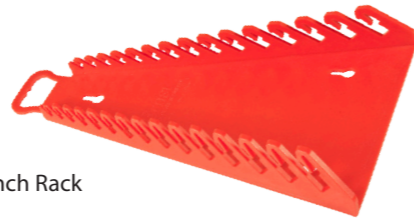

REVERSE Wrench Rack



STANDARD Wrench Rack



**COMBINATION INTERNAL / EXTERNAL SNAP RING PLIERS SETS ('V' SWITCH) NEW**

Part No.	Tip	Angle	Part No.	Tip	Angle
LG3583	.038	0°	LG3589	.070	0°
LG3584	.038	45°	LG3590	.070	45°
LG3585	.038	90°	LG3591	.070	90°
LG3586	.047	0°	LG3592	.090	0°
LG3587	.047	45°	LG3593	.090	45°
LG3588	.047	90°	LG3594	.090	90°

Includes tip diameters of 0.038", 0.047", 0.070" and .090" at 0, 45 and 90 degree angles - Easily convert between internal and external configurations without separating the handles - cushioned grip handles for comfort - Heat treated steel for durability.

6 Piece Combination Set No. **LG3597**



12 Piece Combination Set No. **LG3595**



**INTERNAL / EXTERNAL SNAP RING PLIERS SETS**

Part No.	Tip	Angle	Part No.	Tip	Angle
LG3483	.038	0°	LG3489	.070	0°
LG3484	.038	45°	LG3490	.070	45°
LG3485	.038	90°	LG3491	.070	90°
LG3486	.047	0°	LG3492	.090	0°
LG3487	.047	45°	LG3493	.090	45°
LG3488	.047	90°	LG3494	.090	90°

6 Piece Combination Set No. **LG3497**



12 Piece Combination Set No. **LG3495**



**QUICK SWITCH INTERNAL & EXTERNAL REPLACEMENT**

- Convert between internal and external with a quick flip of a switch
- A once relatively time consuming and complicated process is made easy by eliminating the jaw aligning pushpin process
- Double-dipped custom grip made of low-temp, high-impact material for comfort and durability
- Spring return handles
- Each pliers includes a tip kit containing five pairs of durable alloy, colour-coded, interchangeable tips and Allen wrench, all stored in handy pouch
- Also included are a set of thumbscrews that can be screwed in quickly for light-duty applications
- Most user friendly convertible pliers on the market
- Will replace 10 or more of any single competitor's pliers



Part No.	Internal	External
HT1421	1/4" - 1" 7mm - 26mm	1/8" - 1" 3mm - 26mm
HT1434	3/8" - 2" 10mm - 51mm	1/4" - 2" 7mm - 51mm
HT75	1-13/16" - 4" 46mm - 102mm	1-1/2" - 4" 32mm - 102mm



Contains 3 sets of Lang pliers.  
Made in the USA  
Includes the following pliers in packaging:  
HT1421, HT1434 & HT75

**Model HT1465**

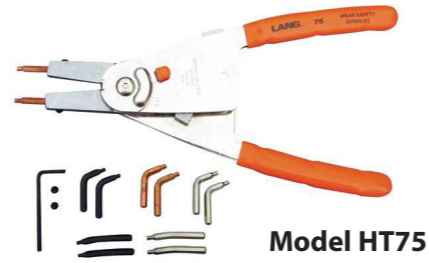

Provides safe and stable service of extra large retaining rings  
Compound screw lever for easy ring installation and removal  
Includes 6 pairs of alloy steel colour coded tips & a hex key  
Internal 3-1/2" - 7" / 90mm - 175mm External 3-1/2" - 7" / 90mm - 175mm

**Model HT87**

**48 PIECE MASTER THREAD RESTORER KIT**

Properly repair or renew damaged threads.

**Part No LG0971**

**Contents-**

**Rethreader taps**

UNC	UNF	Metric	
1/4" - 20	1/4" - 28	6 x 1.00	12 x 1.25
5/16" - 18	5/16" - 24	8 x 1.25	12 x 1.50
3/8" - 16	3/8" - 24	10 x 1.00	12 x 1.75
7/16" - 14	7/16" - 20	10 x 1.25	14 x 1.50
1/2" - 13	1/2" - 20	10 x 1.50	
9/16" - 12	9/16" - 18	11 x 1.50	

**Rethreader Dies**

UNC	UNF	Metric	
1/4" - 20	1/4" - 28	6 x 1.00	12 x 1.50
5/16" - 18	5/16" - 24	8 x 1.25	12 x 1.75
3/8" - 16	3/8" - 24	10 x 1.00	14 x 1.50
7/16" - 14	7/16" - 20	10 x 1.25	
1/2" - 13	1/2" - 20	10 x 1.50	
9/16" - 12	9/16" - 18	11 x 1.50	

**Threaded files**

US Thread Pitch	Metric Thread Pitch		
11	16	.75	1.75
12	18	1.00	2.00
13	20	1.25	2.50
14	24	1.50	3.00



Tools are colour coded in gold, black & silver for quick visual identification

**15 PIECE METRIC THREAD RESTORER KIT**

Properly repair or renew damaged threads.

**Part No LG2584**

**Contents-**

**Rethreader taps**

Metric	
6 x 1.00	12 x 1.25
8 x 1.25	12 x 1.50
10 x 1.25	12 x 1.75
10 x 1.50	

**Rethreader Dies**

Metric	
6 x 1.00	12 x 1.25
8 x 1.25	12 x 1.50
10 x 1.25	12 x 1.75
10 x 1.50	

**Threaded files**

Metric Thread Pitch	
.75	1.75
1.00	2.00
1.25	2.50
1.50	3.00



**THREAD RESTORER FILES**

Restore damaged external threads.

**Part No LG2665**

Pitches include (threads per inch):  
11, 12, 13, 14, 16, 18, 20, 24

**Part No LG2670**

Pitches include (mm per thread):  
1.00, 1.25, 1.50, 1.75, 2.00, 2.50, 3.00

**THREAD RESTORER TAPS**

For repair of damaged internal threads on nuts. Chase out damaged threads and remove nicks and burrs without undercutting good threads. Use with standard wrench and light oil.

**6 Piece Metric Set**

**Part No LG2588**

Sizes:  
6 x 1.00  
8 x 1.25  
10 x 1.50  
12 x 1.25  
12 x 1.50  
12 x 1.75



**26 PIECE SAE SET**

Contains 6 UNC & 6 UNF taps, plus 7 UNC & 7 UNF Dies

**Part No. LG2581**



Super Strength High Tech

## MAGNETIC PICK-UP TOOL with POWERCAP

The POWERCAP shields the sides of the magnet from attaching to unwanted surfaces, and increases lifting capacity by over 45% Stainless steel telescoping handle is strong, long & lightweight, comfortable textured cushion grip keeps handle secure even in oily hands

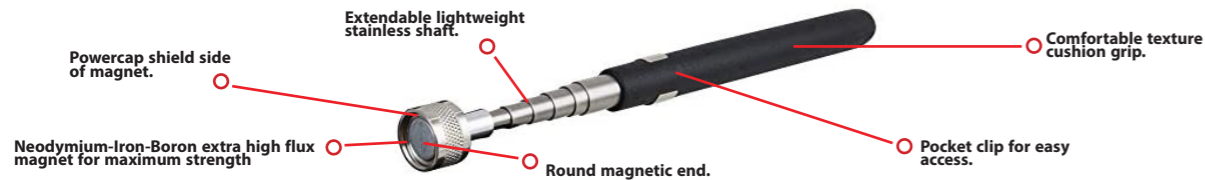

Part No.	Lifts	Handle Length
HT-1	900g	165-845mm
HT-2	2.2kg	165-845mm
HT-3	4.5kg	171-769mm

## HIGH TECH INSPECTION MIRRORS - Longer, Stronger & Lightweight

Stainless steel telescoping handle is strong, long and lightweight comfortable textured cushion grip keeps handle secure even in oily hands. Mirror encased in rugged corrosion resistant brushed stainless steel. All-angle ball joint holds mirror firmly for 360° viewing.

Part No.	Mirror Size	Handle Length
HTE-2	32mm	165-890mm
HTC-2	57mm	165-924mm
HTC-2LM	57mm	300-1295mm
HTS-2	83mm	165-750mm
HTS-2L	83mm	300-1334mm
HTK-2	56 x 87mm	170-650mm

## ULLMAN COUNTER DISPLAY



NEW

### Part No. HT-DISP

Eye catching counter or shelf display for High-tech magnetic pick-up tools & inspection mirrors.

**INCLUDES:**

- 3 x HT-1
- 3 x HT-2
- 3 x HT-3
- 3 x HTE-2
- 3 x HTC-2
- 3 x HTS-2

## FLEXIBLE MAGNETIC PICK UP TOOL

With Powercap bend to any angle.

2.2Kg Pick Up, 735mm Length

Part Number: HT-2FL

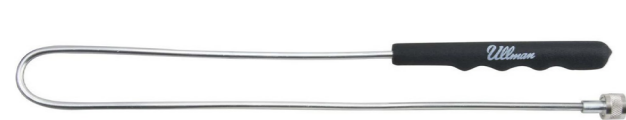

## CIRCULAR FLEXIBLE INSPECTION MIRROR

Bend to any angle mirror

55mm Length 810mm

Part Number: HTC-2FL



NEW

## MG-2 TELESCOPING MAGNIFYING GLASS

Shatter resistant magnifying head Comfortable textured cushion grip handle (175mm extends to 915mm).



## C-2X MAGNETIC BASE INSPECTION MIRROR

With a 2-1/4" diameter round mirror and 7-1/8" overall length, the C-2X inspection mirror can be adjusted for optimal viewing and inspection. The magnetic base and adjustable arm allow hidden areas to be brought into full view in seconds.



## LED LIGHTED INSPECTION MIRRORS



LED Light illuminates dark areas for perfect inspection  
All-angle ball joint holds the round mirror head firmly at any angle for perfect viewing  
Long, strong, and lightweight stainless steel shaft. Non slip cushion handle for wet or oily hands.  
Rectangular model features rotating lights

Part No.	Leds	Mirror Size	Handle Length
HTE-2LT	1	35mm	170-902mm
HTC-2LT	1	60mm	170-940mm
HTS-2LT	3	86mm	170-768mm
HTK-2LT	3	57 x 89mm	171-760mm

## LED LIGHTED MAGNETIC PICK UP TOOLS



Steel Magnetic Head to pick up objects up to 3.6kg.

LED Light illuminates dark areas.

Powercap slides over magnet to shield its sides from unwanted objects.

Long, strong, and lightweight stainless steel shaft. Non slip cushion handle for wet or oily hands.

Part No.	Magnet Capacity	Handle Length
HTLP-1	3.6kg	170 - 705mm
HTLP-2	3.6kg	200 - 832mm
LPT-75	3.4kg	171 - 700mm

# DIGITAL INSPECTION MIRROR

## VIEW & CAPTURE THOSE HARD TO SEE AREAS.

With the Ullman Digital Inspection Mirror, you can increase trust and credibility by showing diagnostic inspection images and videos to your customers.



PART NO: E-DM-1

**720P**  
CAMERA

**SMART INSPECTION**

INCREASE TRUST & CREDIBILITY BY SHOWING INSPECTION IMAGES & VIDEOS TO YOUR CUSTOMERS.

SMARTPHONE ENABLED 720P CAMERA WITH LED ILLUMINATION

DUAL POINT 360° ROTATIONAL KNUCKLE

TELESCOPING STEEL ANTENNA

LED ILLUMINATION

TEXTURED CUSHIONED GRIP

RECHARGEABLE VIA MICRO USB PORT WITH 30 MINUTE RUNTIME

VIEW & SAVE IMAGES TO YOUR SMARTPHONE BY USING THE ULLMAN APP

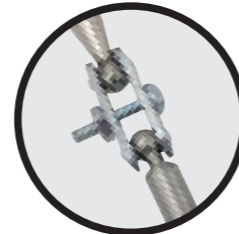

DUAL POINT 360° ROTATIONAL KNUCKLE



RECHARGEABLE VIA MICRO USB PORT WITH 30 MINUTE RUNTIME



SMARTPHONE APP RECORDS PICTURES & VIDEOS

The Ullman Devices Digital Inspection Mirror is a smartphone enabled 720p camera with LED illumination. Users can connect this product to their phone through a downloadable app. This new device is rechargeable via micro USB port with a 30-minute run-time. Technicians can use this device to help increase trust and their credibility by showing inspection images and videos to customers that can be stored on their phones and viewed later.

## FLEXIBLE SPRING CLAMP RANGE



16MLT

16LT

Part No.	Description	Handle Length
16 (Ullman)	Bright plated, flexible, steel spring	684mm
16LT	LED Lighted, flexible, steel spring	645mm
16MLT	LED Lighted, Magnetic, flexible steel spring Mag lifts 2.25kg	642mm

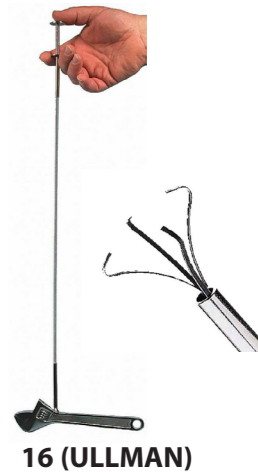

16 (ULLMAN)

## SCREW STARTERS

Suit ferrous or non-ferrous screws tool releases & resets automatically. Features pocket clip & magnet

Part No.	Description
Model D-2	Suits slotted screws
Model PD-10	Suits Phillips® Head screws
Model F-2	Suits Torx® T-10, T-15, T-20, T-25, T-27, T-30 & most Allen Hex and Phillips® Head screws



## POCKET TELESCOPIC MAGNETIC RETRIEVING TOOLS

Powerful enough to pick up objects weighing 680g. Closes down to 150mm, extends to 650mm

Part No.	Colour
15X	Chrome
15X0R	Bright Orange
15XGR	Neon Green



## MAGNETIC RAIL 10-1/4"

Ullman's strong N35 magnets allow rail to be mounted to benches, toolboxes and inside of service vehicles. Mounting holes allow rails to adhere to walls and other non-magnetic surfaces. The Ullman Magnetic Rails allow you to neatly organize your tools and sockets, saving you time from sifting through cluttered drawers and tool boxes.



Part No.	Colour
UMR10	Chrome

**NEW**



## SOCKET HOLDERS WITH HEAVY DUTY SPRING CLIPS.

Bright, durable, plated steel rail with slide-on spring clips to hold sockets tight & rattleproof 430mm length

Part No.	Drive Clips
#25	16 x 1/4"
#35	16 x 3/8"
#50	16 x 1/2"
#75	8 x 3/4"



## HOOK AND PICK SETS

### PSP-4

Each hook & pick is made of high carbon polished steel and is permanently inserted into a sturdy plastic handle.



### CHP4-L

Extra long hook & pick set with textured cushion grip handles. Each item 250mm long



### CHP4-LT



LED Lighted Four Piece Hook & Pick Set

Ideal for separating wires, removing small fuses or o-rings, retrieving and marking metal in dark or hard to view areas.

- Includes 90 degree,
- Each tool 250mm long.
- Durable Carbon Polished Heat-Treated Steel Ergonomic Composite Handle with On/Off Button
- High Intensity LED Light illuminates the work area

## SW-10 SWINGER

Combination reversible pick & hook. Like an extra long finger for jobs in awkward places. Just swivel out the end you want, the other tucks safely away.



## 1830 POCKET SCRIBER

Sharp tungsten carbide tip cuts into hard surfaces, leave clear mark on metal, glass, plastic, tools.

All in one "Push-Click" SAFETY COVER on tungsten carbide with magnetic pick up.



## 1810 DOUBLE POINTED SCRIBER

Scriber has straight and 90 degree angle points for marking in awkward places.

Knurled aluminium handle.

Heat treated bright polished, high carbon needle steel points

Overall length 240mm



## H4W

Aluminium handle with 4 screw-in tips

Zippered top vinyl pouch



## UNIVERSAL SPARK PLUG GAP GAUGE

Easy to read.

Scaled from .020" to .100" (0.5mm to 2.4mm) Pewter plating makes the inches and millimetres more legible for the user to read Easy accurate spark plug adjustment

### SG-2



# ULLMAN LED LIGHTING RANGE

## NEW & IMPROVED

### ROTATING MAGNETIC LED WORK LIGHT RT-3SMD (REPLACES RT-2LT)

The RT-3SMD's sturdy aluminum housing with 3 high-intensity SMD LEDs is rated 110 Lumens. A rotating head easily adjusts to illuminate dark spaces, while the magnetic base attaches to any metal surface in seconds for hands-free use. Three AAA batteries are included.

**Part No. RT-3SMD**



### FLEXIBLE MAGNETIC SMD LED WORKLIGHT

Durable aluminum housing  
3 x High Intensity SMD LED lights provide a brightness of 110 Lumens. Heavy duty spring adjusts light beam to required angle with limitless positions. 3 x AAA batteries included  
Strong magnetic base with hang hook

**Part No: FL-3SMD**



### ROTATING MAGNETIC LED WORK LIGHT

(6) SMD LED's  
375 Lumens  
Sturdy Aluminum Housing  
Head Rotates light Beam to Needed Angle  
Strong Magnet will Attach to Metal Surfaces  
Contains (3) AA Batteries

**Part No: RT-6SMD**



### LED CLAMP WORK LIGHT

6 SMD work light with clamp for hands free use. 375 Lumens  
Colour anodised aluminium housing  
Durable dual injection grip clamp with soft grip 3" clamping jaw.  
Continuous 3 Hour run time.  
Supplied with 3 AA Alkaline batteries

**Part No: CL-6SMD**





## LED LIGHT RANGE



### 3 IN 1 LED 10W SOLAR POCKET LAMP

One Tool with 3 Features: Power Bank, Work Light & Solar Panel. Features include  
 USB Charger Port  
 U Shaped Bracket  
 Micro USB Capable  
 Removable Super Strong Magnetic Attachment  
 4400 mAh Power Bank  
 LED to 450 Lumens  
 5 Hour Run Time without Charge  
**Part Number MGLS75311**



### LED FLASHLIGHT

New MAXIGEAR torch featuring:  
 Adjustable Beam  
 USB Rechargeable  
 3 Modes - FULL, HALF, FLASHING.  
 LED to 130 Lumens  
**Part Number MGLF75310**



### RECHARGEABLE LED HEAD LAMP

LED 200 Lumens - Light Range up to 150 Metres  
 IPX4 Splashproof - resistant from any direction.  
 Battery: Built in 1200mah li-polymer battery  
 USB Rechargeable.  
 Net weight: 72g - Lightweight!  
 Multi Lighting Modes:  
 Full Brightness, Half Brightness, Sensor & Pulse.  
 Sensor controlled by secondary switch.  
 Adjustable Strap  
 Multi Angle

**Part Number MGLH75020**



## STRAIGHT EDGES



Finished precision ground on both sides & edges  
 One edge bevelled to 35°

Carbon Steel - Ungraduated / no size markings

Part No.	Length	Width	Thickness	Markings
SE1.5M	1.5 metre	40mm	8mm	plain
SE2M	2 metre	40mm	8mm	plain
SE3M	3 metre	50mm	8mm	plain

Carbon Steel - Graduated markings every 1mm

Part No.	Length	Width	Thickness	Markings
SE500GRAD	500mm	40mm	8mm	1mm
SE1MGRAD	1 metre	40mm	8mm	1mm
SE1.5MGRAD	1.5 metre	40mm	8mm	1mm
SE2MGRAD	2 metre	40mm	8mm	1mm
SE3MGRAD	3 metre	50mm	8mm	1mm

Stainless Steel - Ungraduated / no size markings

Part No.	Length	Width	Thickness	Markings
SE1MSS	1 metre	40mm	8mm	plain
SE2MSS	2 metre	50mm	8mm	plain

Stainless Steel - Graduated markings every 1mm

Part No.	Length	Width	Thickness	Markings
SE1MGRADSS	1 metre	40mm	8mm	1mm
SE2MGRADSS	2 metre	50mm	8mm	1mm
SE500MGRADSS	500mm	40mm	8mm	1mm

Carbon Steel - Precision Straight Edge

Supplied with certification to DIN 874/0 or 874/1

Lapped on all 4 square sides. Ungraduated / No size markings - CERTIFIED

Part No.	Length	Width	Thickness	Standard
SE1000GR0	1 metre	60mm	12mm	874/0
SE1000GR1	1 metre	50mm	10mm	874/1
SE1500GR1	1.5 metre	60mm	12mm	874/1
SE2000GR0	2 metre	80mm	15mm	874/0
SE2000GR1	2 metre	70mm	15mm	874/1

### MEASURING WEDGES

For measuring of gap dimensions  
 Special steel, ground on all sides, chrome plated  
 scale laser cut, knurled handle  
 Dimensions 153 x 12 x 8mm

Part No.	Range	Reading
MW0511	0.05 - 11mm	0.1mm

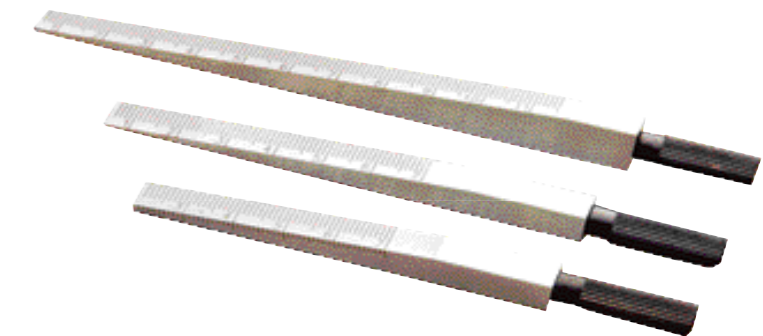



## DRILL CHUCKS - PORTABLE POWER TOOLS



COMPLIMENTING OUR PREMIUM QUALITY LLAMBRICH RANGE OF INDUSTRIAL CHUCKS & ACCESSORIES, OUR MAXIGEAR ECONOMY DRILL CHUCKS ARE A DURABLE, RELIABLE, & COST EFFECTIVE OPTION FOR A STATIONERY EQUIPMENT SUCH AS BENCH AND PEDESTAL DRILLS.

### MAXIGEAR ECONOMY KEYED CHUCKS

Model No.	Capacity mm	Mount K	Key	Sizes O	mm L1	L2
CK13AC6JT	1-13MM	J-6	K3	-	-	-
CK16AC3JT	1-16mm	J-3	K4	-	-	-

### THESE CHUCKS COME IN A BALL BEARING CONSTRUCTION

\*THESE CHUCKS ARE SUPPLIED IN STURDY PLASTIC CONTAINER.

### CHUCK, KEY AND ARBOR COMPLETE

Model No	Range	Mount
CK13AC2MT	1 - 13mm	2 Morse Taper
CK13AC3MT	1 - 13mm	3 Morse Taper
CK13AC4MT	1 - 13mm	4 Morse Taper
CK16AC2MT	1 - 16mm	2 Morse Taper
CK16AC3MT	1 - 16mm	3 Morse Taper
CK16AC4MT	1-16mm	4 Morse Taper

### MAXIGEAR ECONOMY KEYLESS CHUCKS

Model No.	Capacity mm	Mount K	Sizes O	mm L1	L2
CL13AC6JT	1-13MM	J-6	-	-	-
CL16AC6JT	1-16mm	J-6	-	-	-

\*THESE CHUCKS ARE SUPPLIED IN STURDY PLASTIC CONTAINER.

### CHUCK AND ARBOR COMPLETE

Model No	Range	Mount
CL13AC2MT	1 - 13mm	2 Morse Taper
CL13AC3MT	1 - 13mm	3 Morse Taper
CL13AC4MT	1 - 13mm	4 Morse Taper
CL16AC2MT	1 - 16mm	2 Morse Taper
CL16AC3MT	1 - 16mm	3 Morse Taper
CL16AC4MT	1 - 16mm	4 Morse Taper

\*PIN CHUCKS ALSO AVAILABLE, REFERENCE PAGE 138\*



### ALL METAL KEYLESS CHUCKS



Manufactured in Spain



Manufactured in Spain

Keyless Drill Chuck with metal body, locking mechanism and carbide jaw-inserts. With a locking mechanism, no key is required for closing or opening, for hammer drilling and also screwdriver operations. Carbide jaw-inserts (for 13mm capacity) reduce bit slippage and enhance wear resistance. Ergonomic and strong design with full metal sleeves in black oxide finish that eliminate the possibility of rust. With through hole for clockwise and anticlockwise rotation. Supplied with screw M5 (R-3/8") or M6 (R-1/2") to fix chuck to drilling machine. Fits any type of drill (up to 1000W) via UNF thread, male and female. Wide range of accessories (see more info in our Price List)

Model No.	Capacity mm	MOUNT K	O	SIZES MM L1	L2
CPM-10 R-3/8	1-10	3/8-24	41	54.5	64.5
CPM-10 R-1/2	1-10	1/2-20	41	54.5	64.5
CPM-13 R-3/8	2-13	3/8-24	43	62.5	74.5
CPM-13 R-1/2	2-13	1/2-20	43	62.5	74.5

Light-Duty Drill Chuck with key for portable drilling machines.

Ideal for electric portable drilling machines, with or without batteries, cutting direction reversible or non reversible.

Fits tools of up to 16mm.

Fits to machine via UNF screw fittings, male and female, DIN-238 and E-6.3.

Model No.	Capacity mm	MOUNT K	Key	O	SIZES MM L1	L2
CL-06-ATOR	1 - 6.5	1/4 hex	LKC4	30	44	55
CL-06-R-3/8	1 - 6.5	3/8-24	LKC4	30	44	55
CL-10 R-1/2	1-10	1/2-20	KG	33	50	60
CL-10 R-3/8	1-10	3/8-24	KG	33	50	60
CL-13 B-16	1-13	B-16	S2	43	59	73
CL-13 R-1/2	1.5-13	1/2-20	S2	43	59	73
CL-13 R-3/8	1.5-13	3/8-24	S2	43	59	73
CL-16 B-16	3-16	B-16	K3	54	66	66

### DRILL CHUCKS - KEYED - BALL BEARING INDUSTRIAL

#### KEYED CHUCKS



Manufactured in Spain

Ball Bearing Drill Chuck with key for production drilling equipment.

Drill chuck with key for industrial applications that require the toughest machining conditions. Equipped with ball bearings to reduce friction in the tightening mechanism and provide a better grip on the drill shaft.

All the pieces are hardened and ground.

The one piece gear ring and sleeve eliminate the possibility of tooth breakage.

Fits tools of up to 25mm (1"), machine fitting via Jacobs tapers.

Model No.	Capacity mm	Mount K	Key	Sizes O	mm L1	L2	Equivalent size
CBB-08 J2	1-8mm	J-2S	LK30SB	47	55	70	-
CBB-10 J2	1-10mm	J-2S	LK32S9	47	55	70	11N
CBB-13 J3	1-13mm	J-3	LS3	62	75	94	14N
CBB-13 J6	1-13mm	J-6	LS3	62	75	94	-
CBB-16 J3	1-16mm	J-3	LK4S13	67	81	102	16N
CBB-19 J4	1-19mm	J-4	LK4S13	75	99	125	18N
CBB-25 J5	5-25mm	J-5	LK5	93	112	147	20N

## DRILL CHUCKS - KEYLESS - INDUSTRIAL



### INDUSTRIAL KEYLESS CHUCKS

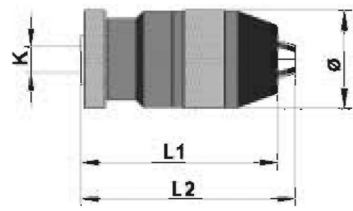

Industrial keyless drill chuck for portable drilling machines or stationery machines.

Drill chucks for industrial use (medium duty), available with screw fittings for professional portable drilling machines and with taper fittings for stationery drilling machines.

Automatic fitting for efficient, fast change of tools.

Self tightening mechanism automatically increases the grip in proportion to the increase in torque during the drilling and avoids the tool slipping in clockwise rotation.

Fits tools of up to 20mm in diameter.

Machine fitting via DIN-238 or Jacobs tapers and UNF thread fittings.



Manufactured in Spain

Model	Capacity	Mount		Sizes mm			Equivalent
No.	mm		O	L1	L2	size	
CKS-04 J-1	0,5-4	J1	26	50	55	-	
CKS-06 R-3/8	0,5-6,5	3/8-24	34	63	70	-	
CKS-06 J-1	0,5-6,5	J1	34	63	70	-	
CKS-08 J-2S	0,8-8	J2	37	72	78	-	
CKS-10 J-2	0,8-10	J2	40	79	86	-	
CKS-10 R-3/8	0,8-10	3/8-24	37	72	78	-	
CKS-13 B-16	1-13mm	B-16	47	93	103	-	
CKS-13 J-2	1-13mm	J2	47	93	103	-	
CKS-13 J-33	1-13mm	J33	47	93	103	-	
CKS-13 J-6	1-13mm	J6	47	93	103	33366	
CKS-13 R-1/2	2-13 mm	1/2-20	40	76	83	33363D	
CKS-13 R-3/8	2-13 mm	3/8-24	40	76	83	-	
CKS-16 B-16	3-16mm	B-16	52	95	105	-	
CKS-16 B-18	3-16mm	B-18	52	95	105	-	
CKS-16 J-6	3-16mm	J-6	52	95	105	33370	
CKS-16 R-1/2	3-16mm	1/2-20	52	95	105	-	
CKS-16 R-5/8	3-16mm	5/8-16	52	95	105	-	

### KEYLESS CHUCKS WITH MORSE TAPER ARBORS

Model No	Range	Mount
CKS-13-2MT	1 - 13mm	2 Morse Taper
CKS-13-3MT	1 - 13mm	3 Morse Taper
CKS-13-4MT	1 - 13mm	4 Morse Taper
CKS-16-2MT	3 - 16mm	2 Morse Taper
CKS-16-3MT	3 - 16mm	3 Morse Taper
CKS-16-4MT	3 - 16mm	4 Morse Taper

Note - Chucks supplied with arbor, they are not integral mounted.



Simplify the ordering process.  
Order the chuck complete  
with the Morse Taper arbor  
Manufactured in Spain

## DRILL CHUCKS - KEYED - INDUSTRIAL

### KEYED INDUSTRIAL CHUCKS

Industrial drill chuck with key for stationary machines and portable drilling machines. Specially designed for stationary drilling, turning, milling and wood working machines. The one piece gear ring and sleeve eliminate the possibility of tooth breakage.

The jaws, gear ring and body are all totally hardened to avoid wear and lengthen the life of the drill chuck.

Fits tools of up to 19mm in diameter. (3/4")

Machine fitting via DIN-238 or Jacobs tapers and UNF screw fittings.

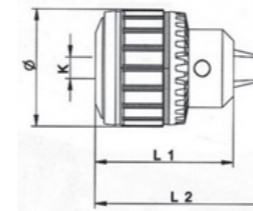

Manufactured in Spain

\* Extra Heavy Duty Models

Simplify the ordering process.  
Order the chuck complete  
with the Morse Taper arbor  
Manufactured in Spain

Model	Capacity	MOUNT		SIZES	MM		Equivalent
No.	mm	K	Key	O	L1	L2	Size
CY-04 J-0	0,8-4	J-0	LK0	22	29	36	0
CY-06 J-1	0,8-6,5	J-1	LKC4	32	40	49	1A
CY-06 R-3/8	0,8-6,5	3/8-24	LKC4	32	42	52	1B3/8
CY-10 B-12	1-10mm	B-12	LS2	37	51	60	
CY-10 B-16	1-10mm	B-16	LS2	43	53	68	
CY-10 J-1	1-10mm	J-1	LS2	37	51	60	31-01
CY-10 J-2	1-10mm	J-2	LS2	37	51	60	2A
CY-10 R-3/8	1-10mm	3/8-24	LS2	37	51	60	41BA3/8
CY-10 R-1/2	1-10mm	1/2-20	LS2	37	51	60	41BA1/2
CY-13 B-16	1.5-13mm	B-16	LK2	46	62	77	-
CY-13 J-6	1.5-13mm	J-6	LK2	46	62	77	
CYX-13 J-6*	1-13mm	J-6	LK3	53	69	89	34-06
CY-13 J-33	1.5-13mm	J-33	LK2	46	62	77	34-33
CY-13 R-3/8	1.5-13mm	3/8-24	LK2	46	62	77	33BA3/8
CY-13 R-1/2	1.5-13mm	1/2-20	LK2	46	62	77	33BA1/2
CY-13 R-5/8	1.5-13mm	5/8-16	LK2	46	62	77	33BA5/8
CY-16 J-3	1-16mm	J-3	LK3	57	77	95	3A
CY-16 B-16	1-16mm	B-16	LK3	57	77	95	-
CY-16 B-18	1-16mm	B-18	LK3	57	77	95	-
CY-16 J-6	1-16mm	J-6	LK3	57	77	95	-
CY-16 R-1/2	1-16mm	1/2-20	LK3	57	77	95	35B1/2
CY-16 R-5/8	1-16mm	5/8-16	LK3	57	77	95	3B5/8
CY-19 J-3	5-20mm	J-3	LK4	65	85	110	36
CY-19 R-3/4	5-20mm	3/4-16	LK4	68	85	110	36B3/4
CY-19 R-5/8	5-20mm	5/8-16	LK4	68	85	110	36B5/8

### KEYED CHUCKS WITH MORSE TAPER ARBORS

Model No	Range	Mount
CY-13-2MT	1 - 13mm	2 Morse Taper
CY-13-3MT	1 - 13mm	3 Morse Taper
CY-16-2MT	1 - 16mm	2 Morse Taper
CY-16-3MT	1 - 16mm	3 Morse Taper
CY-16-4MT	1 - 16mm	4 Morse Taper
CY-19-3MT	5 - 20mm	3 Morse Taper
CY-19-4MT	5 - 20mm	4 Morse Taper

Note - Chucks supplied with arbor, they are not integral mounted.



## ACCESSORIES

Chuck sold separately

### SDS+ ADAPTOR

To fit a chuck with a 1/2-20 mount to an SDS power tool

Part No. CBSDS-1/2



### HEX ADAPTOR

Adapt a chuck with 1/4" Hex to 3/8-24 Thread  
Part No. CB1/4HEX-3/8



## CHUCK KEYS



Part No.	Description	Pilot (mm)	Pilot (inches)	Teeth
LK0	CHUCK KEY SUIT CY-04 LLAMBRICH & 0 SERIES JACOBS	3.17	1/8"	11
LK0M	CHUCK KEY STAINLESS SUIT CSS-04 LLAMBRICH & 0 SERIES JACOBS	3.17	1/8	11
LK1M	CHUCK KEY STAINLESS SUIT CSS-06 LLAMBRICH & 1 SERIES JACOBS	3.97	5/32	11
LK1S7	CHUCK KEY SUIT 1 SERIES & S7 DIN	3.97	5/32"	11
LK2S17	CHUCK KEY SUIT CY-13 & 2 SERIES JACOBS	6.35	1.4"	11
LK30S8	CHUCK KEY SUIT CBB-08 LLAMBRICH & 41 SERIES & 8-1/2N JACOBS	5.95	-	10
LK32S9	CHUCK KEY SUIT CBB-10 LLAMBRICH & 33 SERIES & 11N JACOBS	6.35	-	10
LK3S10	CHUCK KEY SUIT CL-16, CYX-13, CY-16 LLAMBRICH & 3, 34 SERIES & 14N JACOBS	7.94	5/16"	11
LK4S13	CHUCK KEY SUIT CY-19, CBB-16, CBB-19 LLAMBRICH & 36 SERIES, 16N, 18N JACOBS	9.52	3/8"	12
LK5	CHUCK KEY SUIT CBB-25 LLAMBRICH & 20N JACOBS	11.11	7/16"	12
LKC4	CHUCK KEY TO SUIT CY-06 SERIES LLAMBRICH	5.42	7/32	12
LKGS14	CHUCK KEY SUIT CL-10 LLAMBRICH & 10MM JACOBS MULTICRAFT	6.5	9/32"	11
LKK	CHUCK KEY SUIT 22BA, 24BA, SERIES JACOBS	7.14	11/32"	10
LS1	CHUCK KEY SUIT ROHM PRIMA SERIES & LFA 4mm 6mm & 8mm	4.00	-	10
LS2	CHUCK KEY SUIT CL-13, CY-10 LLAMBRICH & ROHM PRIMA SERIES 8MM, 10MM, 13MM	6.00	-	12
LS3	CHUCK KEY DIN SERIES S3 8mm PILOT	8.00	-	12

## INOX STAINLESS STEEL DRILL CHUCKS

The most complete Stainless Steel Drill Chuck Program, available in Keyed, Keyless, and also in Hybrid model types. For use in the medical, dental, and food industries

Manufactured from stainless steel to withstand corrosion. All FGE & GE models are bead blasted with glass balls and have passivation by an electro-polishing technique. This adds additional protection against all types of corrosion, eliminates undesirable residual contaminants, and improves the finish of the surface profile.

Model	Capacity	Mount		Sizes mm		
No.	mm	K	O1	O2	L1	Key
<b>KEYED</b>						
CSS-04-J0-GE	0.5 - 4mm	J0	22	28	35	LK0M
CSS-06R3/8-GE-DS	0.5 - 7.4mm	3/8-24	28.4	40	50.3	LK1M

Manufactured in Spain



## SP SUPER PRECISION KEYLESS DRILL CHUCK

Model	Capacity	Mount		Sizes mm	
No.	mm		O	L1	L2
SP-13-J6	1-13mm	6JT	49	91	103
SP-16-J6	3-16mm	6JT	55	95	107

Manufactured in Spain



## SPS-SOLID SUPER PRECISION KEYLESS DRILL CHUCK WITH INTEGRATED SHANK (MORSE TAPER)

Model	Capacity	Mount		Sizes mm	
No.	mm		O	L1	L2
SPS-13-MT2	1-13mm	2MT	48	80	92
SPS-13-MT3	1-13mm	3MT	48	80	92
SPS-16-MT3	3-16mm	3MT	54	85	96
SPS-16-MT4	3-16mm	4MT	54	85	96

Manufactured in Spain



## ASL & AKL WRENCH LOCK & KEY LOCK SUPER PRECISION KEYLESS CHUCKS

Albrecht offers two drill chuck models designed specifically for CNC machining centres. ASL models have a wrench lock facility to allow extra tightening force to be applied. AKL models have a non-rotating hood - the chuck is opened & closed via a hex key inserted into the side of the body. Key-Lock models can be run forward & reverse and are the most accurate chucks available. Key-Lock models are excellent for use on CNC machining centres because sudden braking will not cause chuck to open.



Model No	Capacity	Mount
ASL130-ISO40	1 - 13mm	ISO40
ASL130-BT40	1 - 13mm	BT40
ASL160-ISO40	1.5 - 16mm	ISO40
ASL160-BT40	1.5 - 16mm	BT40
AKL130-BT40	1 - 13mm	BT40
AKL160-ISO50	1.5 - 16mm	ISO50
AKL160-BT40	1.5 - 16mm	BT40

# ALBRECHT

## SBF SUPER PRECISION KEYLESS CHUCKS

- Albrecht chucks incorporate a unique self-tightening feature, which causes them to grip drills tighter as more torque is applied.
- Even when high torque is applied, the chucks can be easily opened by hand.
- All parts exposed to wear are hardened and ground for accuracy and long life.

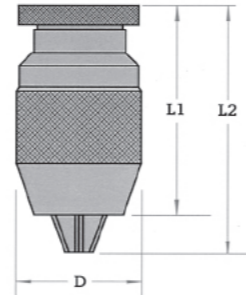

Manufactured in Germany



### SBF SUPER DRILL CHUCK

Model No.	Capacity Range	Mount	Balanced max RPM	Unbalanced max RPM
SBFC30-J0	0.2 - 3mm	J0	35,000	7,500
SBFC30-J1	0.2 - 3mm	J1	35,000	7,500
SBFC65-J1	0 - 6.5mm	J1	25,000	4,000
SBFC100-J2	0 - 10mm	J2	12,000	3,000
SBFC130-J6	1 - 13mm	J6	7,000	2,800
SBFC130-B16	1 - 13mm	B16	7,000	2,800
SBFC160-J6	3 - 16mm	J6	4,000	2,500
SBFC160-B16	3 - 16mm	B16	4,000	2,500

### SBF-PLUS SUPER DRILL CHUCK

- Integral shank design is more compact than a combined drill chuck and arbor resulting in:  
GREATER ACCURACY  
GREATER RIGIDITY  
LARGER WORK ENVELOPE
- Integral shank eliminates the possibility of a chuck slipping on its arbor

Model No.	Capacity Range	Shank Type	Open L1	Closed L2	Sleeve D
SBFP130-MT2	1 - 13mm	MT2	86mm	98.5mm	50mm
SBFP130-MT3	1 - 13mm	MT3	86mm	98.5mm	50mm
SBFP130-R8	1 - 13mm	R8	88mm	97mm	50mm
SBFP160-MT3	3 - 16mm	MT3	90mm	104mm	57mm
SBFP160-MT4	3 - 16mm	MT4	92mm	104mm	57mm
SBFP160-R8	3 - 16mm	R8	89mm	100mm	57mm

### REPLACEMENT PARTS

Description	Part No.
Jaw set 13mm	1060130 000
Jaw set 16mm	1060160 000
Body & spindle 13mm J6	1240130 J06
Body & spindle 16mm J6	1240160 J06

Other spares are carried ex-stock. Price on application



## INDUSTRIAL TOOLHOLDERS

### ARBORS

Features

- Precision machined and ground for maximum performance.
- Ideal for use with custom tool and work holder designs.



### MORSE TAPERS

Morse Taper No.	D-1 mm	D-2 mm	L-1 mm
1	12.065	9.70	65.5
2	17.780	14.90	80
3	23.825	20.20	99
4	31.267	26.50	124
5	44.399	38.20	156
6	63.348	54.60	218

### JACOBS TAPERS

Jacobs Taper No.	D-3 mm	D-4 mm	L-2 mm
0	6.350	5.802	11.112
1	9.754	8.469	16.669
2 short	13.940	12.386	19.050
2	14.199	12.386	22.225
33	15.850	14.237	25.400
6	17.170	15.582	25.400
3	20.599	18.951	30.956
4	28.550	26.346	42.069
5	35.890	33.422	47.625

### DIN (METRIC) TAPERS

DIN Taper No.	D-3 mm	D-4 mm	L-2 mm
B10	10.094	9.40	14.50
B12	12.065	11.10	18.50
B16	15.733	14.50	24.00
B18	17.780	16.20	32.00
B22	21.793	19.80	40.50
B24	23.825	21.30	50.50

## MORSE TO JACOBS & DIN (B) TAPERS

Part No.	Equivalent	Description	Overall Length mm
MT0JT0	-	0 Morse x 0JT	75mm
MT1JT0	-	1 Morse x 0JT	80mm
MT1JT1	-	1 Morse x 1JT	84mm
MT1JT2	A0102	1 Morse x 2JT	91mm
MT1JT6	A0106	1 Morse x 6JT	95mm
MT1JT33	-	1 Morse x 33JT	95mm
MT2JT1	A0201	2 Morse x 1JT	101mm
MT2JT2	A0202	2 Morse x 2JT	106mm
MT2JT3	A0203	2 Morse x 3JT	113mm
MT2JT4	A0204	2 Morse x 4JT	125mm
MT2JT6	A0206	2 Morse x 6JT	107mm
MT2JT33	-	2 Morse x 33JT	109mm
MT3JT1	-	3 Morse x 1JT	119mm
MT3JT2	A0302	3 Morse x 2JT	125mm
MT3JT3	A0303	3 Morse x 3JT	134mm
MT3JT4	A0304	3 Morse x 4JT	145mm
MT3JT5	A0305	3 Morse x 5JT	151mm
MT3JT6	A0306	3 Morse x 6JT	129mm
MT3JT33	-	3 Morse x 33JT	129mm
MT4JT2	-	4 Morse x 2JT	150mm
MT4JT3	-	4 Morse x 3JT	159mm
MT4JT4	A0404	4 Morse x 4JT	170mm
MT4JT5	-	4 Morse x 5JT	175mm
MT4JT6	A0406	4 Morse x 6JT	153mm
MT4JT33	-	4 Morse x 33JT	154mm
MT5JT3	A0503	5 Morse x 3JT	191mm
MT5JT4	A0504	5 Morse x 4JT	202mm
MT5JT5	-	5 Morse x 5JT	207mm
MT5JT6	-	5 Morse x 6JT	187mm
MT1B10	-	1 Morse x B10	85mm
MT1B12	-	1 Morse x B12	88mm
MT1B16	-	1 Morse x B16	93mm
MT2B10	-	2 Morse x B10	98mm
MT2B12	-	2 Morse x B12	102mm
MT2B16	-	2 Morse x B16	108mm
MT2B18	-	2 Morse x B18	116mm
MT3B12	-	3 Morse x B12	121mm
MT3B16	-	3 Morse x B16	127mm
MT3B18	-	3 Morse x B18	135mm
MT3B22	-	3 Morse x B22	143mm
MT4B16	-	4 Morse x B16	152mm
MT4B18	-	4 Morse x B18	160mm
MT4B22	-	4 Morse x B22	168mm
MT5B16	-	5 Morse x B16	184mm
MT5B18	-	5 Morse x B18	192mm

## INDUSTRIAL TOOLHOLDERS



### EXTENSION SOCKETS - MORSE TAPER

Hardened Tang, accurately ground externally.

Part No.	Equivalent Size	Morse Outside	Taper Inside
XMT1MT1	-	1	1
XMT1MT2	-	1	2
XMT2MT1	821	2	1
XMT2MT2	-	2	2
XMT2MT3	-	2	3
XMT3MT1	831	3	1
XMT3MT2	832	3	2
XMT3MT3	-	3	3
XMT3MT4	-	3	4
XMT4MT1	-	4	1
XMT4MT2	842	4	2
XMT4MT3	843	4	3
XMT4MT4	-	4	4
XMT4MT5	-	4	5
XMT5MT1	-	5	1
XMT5MT2	-	5	2
XMT5MT3	853	5	3
XMT5MT4	854	5	4
XMT5MT5	-	5	5



### EJECTING DRIFTS

To eject Morse Tapers from sleeves, sockets and machine spindles.

4 Hardened and tempered

Part No.	To Eject
EDMT0	0 Morse Taper
EDMT12	1 & 2 Morse Taper
EDMT34	3 & 4 Morse Taper
EDMT45	4 & 5 Morse Taper
EDMT6	6 Morse Taper
DD1MTA	1 Morse Taper
DD2MTA	2 Morse Taper
DD3MTA	3 Morse Taper
DD4MTA	4 Morse Taper
DD5MTA	5 Morse Taper
DD1-2MTEA	1 & 2 Morse Taper
DD2-3MTEA	2 & 3 Morse Taper
DD3-4MTEA	3 & 4 Morse Taper



## INDUSTRIAL TOOLHOLDERS



### ARBORS - CONTINUED

Straight Shank to Jacobs Taper

Part No.	Equivalent Size	Overall Description	Length mm
SS6JT0	-	6mm x 0JT	46mm
SS3/8JT0	-	3/8 x 0JT	79mm
SS1/2JT0	-	1/2 x 0JT	79mm
SS1/2JT1	-	1/2 x 1JT	84mm
SS1/2JT2	-	1/2 x 2JT	90mm
SS1/2JT3	-	1/2 x 3JT	98mm
SS1/2JT33	-	1/2 x 33JT	93mm
SS1/2JT6	-	1/2 x 6JT	93mm
SS5/8JT1	-	5/8 x 1JT	84mm
SS5/8JT2	-	5/8 x 2JT	90mm
SS5/8JT3	-	5/8 x 3JT	98mm
SS5/8JT33	-	5/8 x 33JT	93mm
SS5/8JT6	-	5/8 x 6JT	93mm
SS3/4JT2	-	3/4 x 2JT	102mm
SS3/4JT3	-	3/4 x 3JT	111mm
SS3/4JT6	-	3/4 x 6JT	106mm
SS1JT3	-	1 x 3JT	111mm
SS1JT6	-	1 x 6JT	106mm
SS32JT6	-	32mm x 6JT	130mm



### Morse Taper to Threaded Shank

Part No.	Equivalent Size	Description	Overall Length mm
MT2T3/8	A0261	2 Morse x 3/8-24	94mm
MT2T1/2	A0264	2 Morse x 1/2-20	103mm
MT2T5/8	A0268	2 Morse x 5/8-16	106mm
MT2T3/4	-	2 Morse x 3/4-16	106mm
MT3T1/2	-	3 Morse x 1/2-20	122mm

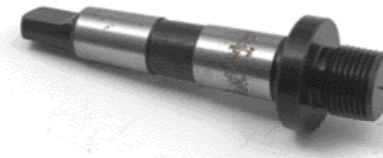

### Bridgeport (R-8) Taper to Jacobs Taper

Part No.	Equivalent Size	Description	Overall Length mm
R8JT2	-	R-8 Bridgeport x 2JT	132mm
R8JT3	-	R-8 Bridgeport x 3JT	140mm
R8JT6	-	R-8 Bridgeport x 6JT	135mm
R8B16	-	R-8 Bridgeport x B16	135mm



**MORSE TAPER TO JACOBS TAPER**

Part No.	Morse Taper	Jacobs Taper
CA0MT0JT	0	0
CA1MT0JT	1	0
CA1MT1JT	1	1
CA1MT2JT	1	2
CA1MT3JT	1	3
CA1MT6JT	1	6
CA1MT33J	1	33
CA2MT0JT	2	0
CA2MT1JT	2	1
CA2MT2JT	2	2
CA2MT3JT	2	3
CA2MT4JT	2	4
CA2MT5JT	2	5
CA2MT6JT	2	6
CA2MT33J	2	33
CA3MT1JT	3	1
CA3MT2JT	3	2
CA3MT3JT	3	3
CA3MT4JT	3	4
CA3MT5JT	3	5
CA3MT6JT	3	6
CA3MT33T	3	33
CA4MT2JT	4	2
CA4MT3JT	4	3
CA4MT4JT	4	4
CA4MT5JT	4	5
CA4MT6JT	4	6
CA4MT33J	4	33
CA5MT3JT	5	3
CA5MT4JT	5	4
CA5MT5JT	5	5
CA5MT6JT	5	6
CA6MT3JT	6	3
CA6MT6JT	6	6

**ROUND SHANK TO JACOBS TAPER**

Part No.	Diameter	Jacobs Taper
CA1/2-0J	1/2"	0
CA1/2-1J	1/2"	1
CA1/2-2J	1/2"	2
CA1/2-3J	1/2"	3
CA1/2-6J	1/2"	6
CA1/2-33J	1/2"	33
CA5/8-1J	5/8"	1
CA5/8-2J	5/8"	2
CA5/8-3J	5/8"	3
CA5/8-4J	5/8"	4
CA5/8-6J	5/8"	6
CA5/8-33J	5/8"	33
CA3/4-2J	3/4"	2
CA3/4-3J	3/4"	3
CA3/4-4J	3/4"	4
CA3/4-6J	3/4"	6
CA3/4-33J	3/4"	33
CA1-3J	1"	3
CA1-4J	1"	4

**MORSE TAPER TO BLANK END**

Part No.	Morse Taper	Blank End Dimensions
CA1MTBLANK	1	22mm x 29mm
CA2MTBLANK	2	25mm x 36mm
CA3MTBLANK	3	25mm x 36mm

**MORSE TAPER TO DIN TAPER**

Part No.	Morse Taper	DIN Taper
CA1MTB10A	1	B10
CA1MTB12A	1	B12
CA1MTB16A	1	B16
CA1MTB18A	1	B18
CA2MTB10A	2	B10
CA2MTB12A	2	B12
CA2MTB16A	2	B16
CA2MTB18A	2	B18
CA2MTB22A	2	B22
CA3MTB12A	3	B12
CA3MTB16A	3	B16
CA3MTB18A	3	B18
CA3MTB22A	3	B22
CA3MTB24A	3	B24
CA4MTB16A	4	B16
CA4MTB18A	4	B18
CA4MTB22A	4	B22
CA4MTB24A	4	B24
CA5MTB16A	5	B16
CA5MTB18A	5	B18
CA5MTB22A	5	B22
CA5MTB24A	5	B24



**ROUND SHANK TO DIN TAPER**

Part No.	Diameter	DIN Taper
CA1/2-B16	1/2"	B16
CA1/2-B18	1/2"	B18
CA5/8-B16	5/8"	B16

Discontinued when current stocks depleted



**MORSE TAPER TO THREADED SHANK**

Part No.	Morse Taper	Thread	Comment
CA1MT3/8TA	1	3/8-24	
CA1MT1/2TA	1	1/2-20	
CA1MT5/8TA	1	5/8-16	
CA2MT3/8TA	2	3/8-24	
CA2MT1/2TA	2	1/2-20	
CA2MT5/8TA	2	5/8-16	
CA3MT3/8TA	3	3/8-24	
CA3MT1/2TA	3	1/2-20	
CA3MT5/8TA	3	5/8-16	

**R-8 (BRIDGEPORT) TO JACOBS AND DIN TAPERS**

Part No.	Bridgeport	Taper	Drawbar Thread
CAR82JTA	R-8	2 Jacobs	7/16 UNF
CAR83JTA	R-8	3 Jacobs	7/16 UNF
CAR86JTA	R-8	6 Jacobs	7/16 UNF
CAR8B16	R-8	B16 DIN	7/16 UNF
CAR8B18	R-8	B18 DIN	7/16 UNF

**TURRET SOCKETS**

Part No.	Morse Taper	Diameter
SOC1MTX1	1	1"
SOC1MTX1.5	1	1-1/2"
SOC2MTX1	2	1"
SOC2MTX1.25	2	1-1/4"
SOC2MTX1.5	2	1-1/2"
SOC2MTX2	2	2"
SOC3MTX1.25	3	1-1/4"
SOC3MTX1.5	3	1-1/2"
SOC3MTX2	3	2"
SOC4MTX1.5	4	1-1/2"
SOC4MTX2	4	2"





**DRILL SLEEVES ECONOMY RANGE** *Manufactured in India*



MORSE TAPER GROUND INSIDE AND OUT		
Part No.	Outside	Inside
	Morse Taper	Morse Taper
DSMT1-0A	1	0
DSMT2-1A	2	1
DSMT3-1A	3	1
DSMT3-2A	3	2
DSMT4-1A	4	1
DSMT4-2A	4	2
DSMT4-3A	4	3
DSMT5-2A	5	2
DSMT5-3A	5	3
DSMT5-4A	5	4
DSMT6-2A	6	2
DSMT6-3A	6	3
DSMT6-4A	6	4
DSMT6-5A	6	5



EXTENSION SOCKETS MORSE TAPER			
Part No.	Outside	Inside	Length
	Morse Taper	Morse Taper	
ESMT1M-1F	1	1	145mm
ESMT1M-2F	1	2	159mm
ESMT1M-3F	1	3	180mm
ESMT2M-1F	2	1	160mm
ESMT2M-2F	2	2	176mm
ESMT2M-3F	2	3	195mm
ESMT2M-4F	2	4	220mm
ESMT3M-1F	3	1	
ESMT3M-2F	3	2	194mm
ESMT3M-3F	3	3	215mm
ESMT3M-4F	3	4	239mm
ESMT3M-5F	3	5	270mm
ESMT4M-2F	4	2	215mm
ESMT4M-3F	4	3	240mm
ESMT4M-4F	4	4	265mm
ESMT4M-5F	4	5	300mm
ESMT4M-6F	4	6	375mm
ESMT5M-3F	5	3	295mm
ESMT5M-4F	5	4	295mm
ESMT5M-5F	5	5	335mm
ESMT5M-6F	5	6	400mm
ESLMT1-300	1	1	300mm
ESLMT2-300	2	2	300mm
ESLMT3-350	3	3	350mm
ESLMT4-350	4	4	350mm



**NT (ISO) & BT DRILL CHUCK ARBORS**



Part No.	Description	Drawbar Thread	Overall Length
SY81512	NT30 x B16	M12 x 1.75	111
SY81533	NT30 x JT3	M12 x 1.75	111
SY81536	NT30 x JT6	M12 x 1.75	111
SY81513	NT40 x B16	M16 x 2.0	139
SY81543	NT40 x JT3	M16 x 2.0	138
SY81546	NT40 x JT6	M16 x 2.0	138
SY81514	NT50 x B16	M24 x 3.0	175
SY16506	BT30 x JT6	M12 x 1.75	117
SY16524	BT40 x JT6	M16 x 2.0	175

**DRILL SLEEVES R-8 (BRIDGEPORT TAPER)**

To enable the use of Morse taper shank tools on Bridgeport taper milling machines



Part No.	Description	Overall length
SY81201	R8 x MT1	124mm
SY81202	R8 x MT2	136.5mm
SY81203	R8 x MT3	150mm

**MILLING MACHINE ADAPTORS**

Used to permit the use of Morse taper shank tools in machines with NT (ISO) tapers



Part No.	Description	Drawbar Thread	Overall length
SY82900	NT30 x MT2	M12 x 1.75	124mm
SY82901	NT30 x MT3	M12 x 1.75	142mm
SY82902	NT40 x MT2	M16 x 2.0	118mm
SY82903	NT40 x MT3	M16 x 2.0	140mm

## 4-IN-1™ UTILITY CLAMPING SYSTEM

**StrongHandTools™**  
Better Tools. Better Price.

### ONE CLAMP - FOUR FUNCTIONS

The most versatile & economical sliding arm clamp available  
Each clamp comes complete with V-Pad and Extender Block  
Threaded hole on the base for mounting attachments  
Removable, reversible arm for spreading



Part No.	Capacity	Throat Depth	Clamp Force	Pads	Tapped Hole	Weight
UD45M-C3	115 mm	80 mm	230 kg	Standard	M8	0.6 kg
UF65M-C3	165 mm	120 mm	460 kg	Standard	M10	1.3 kg
UG85M-C3	215 mm	120 mm	550 kg	Standard	M10	1.9 kg
UM105PM-C3	265 mm	140 mm	1,100 kg	Standard	M10	3.4 kg
UM125M-C3	320 mm	140 mm	1,100 kg	Heavy Duty	M10	3.5 kg
UM205M-C3	520 mm	140 mm	1,100 kg	Heavy Duty	M10	4.5 kg

### LIGHT DUTY SERIES

Part No.	Capacity	Throat Depth	Clamp Force	Pads	Tapped Hole	Weight
UG1257M	320mm	180mm	350kg	Standard	M10	2.7kg
UG1657M	420mm	180mm	350kg	Standard	M10	3.0kg
UG2057M	520mm	180mm	350kg	Standard	M10	3.2kg

### SUPER HEAVY DUTY SERIES

Extra Large, Extra Strong, Sliding Arm Clamps  
Oversize, heavy duty swivel pad  
Durable 42 x 20mm cross section  
Hex head to allow extra tightening  
V-Pads & Extension Blocks sold separately



Part No.	Capacity	Throat Depth	Clamp Force	Pads	Tapped Hole	Weight
UP125M	320 mm	180 mm	2,200 kg	Heavy Duty	M10	5.6 kg
UP165M	420 mm	180 mm	2,200 kg	Heavy Duty	M10	6.2 kg
UP205M	520 mm	180 mm	2,200 kg	Heavy Duty	M10	6.8 kg
UP245M	620 mm	180 mm	2,200 kg	Heavy Duty	M10	7.5 kg
UP315M	800 mm	180 mm	2,200 kg	Heavy Duty	M10	7.6 kg
UP405M	1,020 mm	180 mm	2,200 kg	Heavy Duty	M10	10.0kg
UP605M	1,540 mm	180 mm	2,200 kg	Heavy Duty	M10	10.0kg

## RATCHET ACTION CLAMPS

Ratchet mechanism ensures rapid, vibration and torsion resistant clamping.

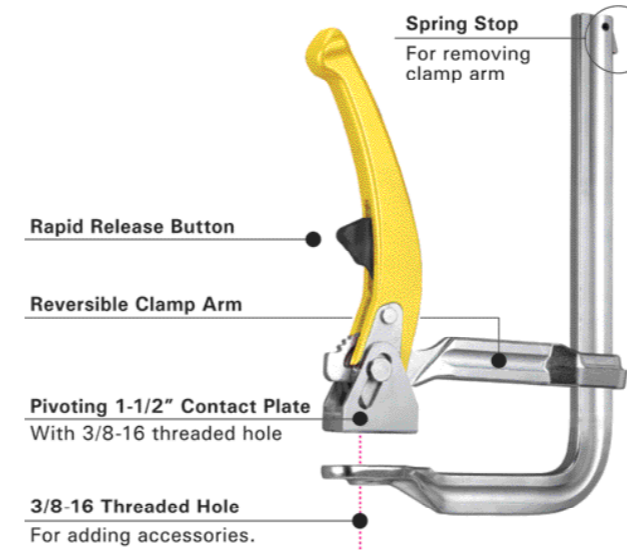

Part No.	Capacity	Clamp Force
UF65RM	178 mm	450 kg
UF100RM	254 mm	450 kg
UF100JRM#	254 mm	450 kg

# J Shaped for stepover applications



## MAGSPRING CLAMPS

The spring-loaded, one-handed clamp with quick-set magnetic V-Pad.  
The Spring Loaded Arm allows users to free up one hand to position the workpiece.



Part No	Capacity	Throat Depth	Pull Force
UDV45M	90mm	83mm	230kg
UDV65M	140mm	83mm	230kg

## THIRD HAND MODULAR CLAMP

Fully Articulated. Fully Adjustable.

"Third Hand" positions your workpiece at any angle for full weld access. Use your THIRD HAND to elevate and firmly hold stock at the ideal angle and height while you weld, cut, sand or paint. Securely hold stock at any position with ball joint adjustment and locking.  
Slotted Adaptor Head accepts Pliers or Clamps to hold round, flat, square or angled stock. Two screws securely hold parts or clamps in position.



Part No.	Description
HAS40	Universal Clamp Welding Table Base
HAS42	Universal Clamp Base Mount

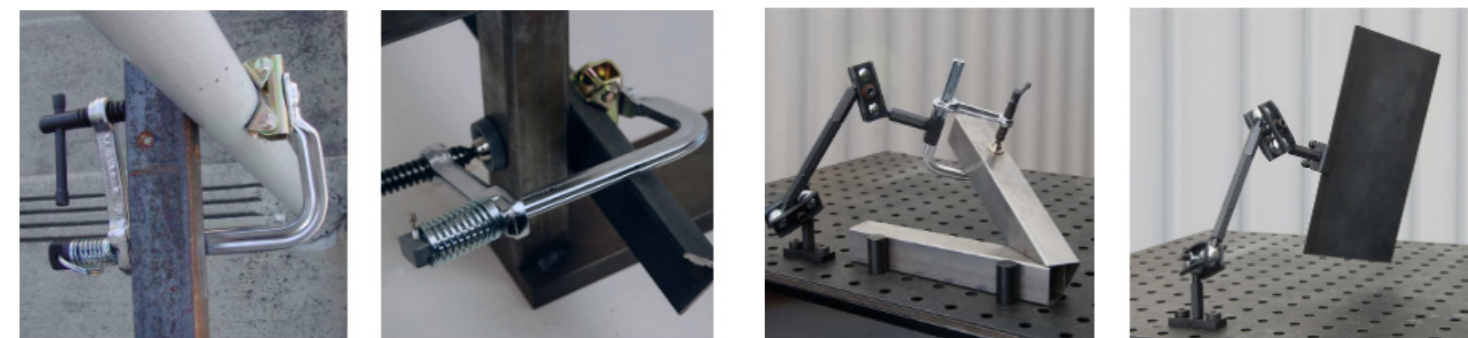

## WELDERS ANGLE CLAMPS - TWO AND THREE AXIS

### 2-AXIS CLAMPS

The best, secure, right angle clamping vise.  
Manufactured from machined cast iron.

Machined outside faces - usable for upright joints

Quick acting screw button for faster set up

Stand-Off increases access

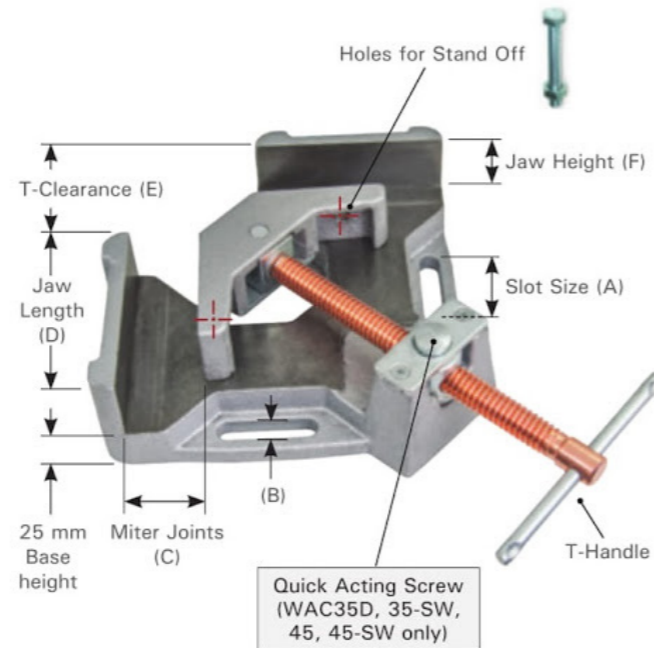

Part No.	Mitre Joints (A)	Jaw Length (B)	T-Clearance	Jaw Height (D)
WAC35D	95 mm	122 mm	62 mm	35 mm
WAC45	121 mm	135 mm	100 mm	57 mm

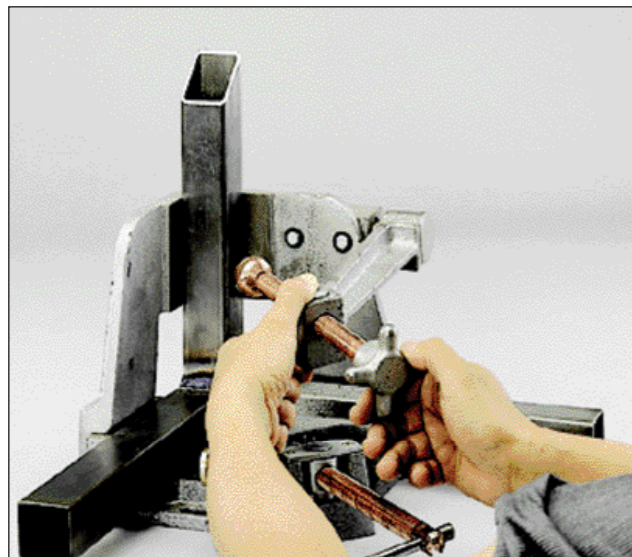

### 3-AXIS CLAMPS

All the features of the 2-axis clamp, plus a third arm which swings out to allow quick and easy removal.

Holds a three axis workpiece in position for welding and leave clamped during cool down to minimize distortion due to contraction.

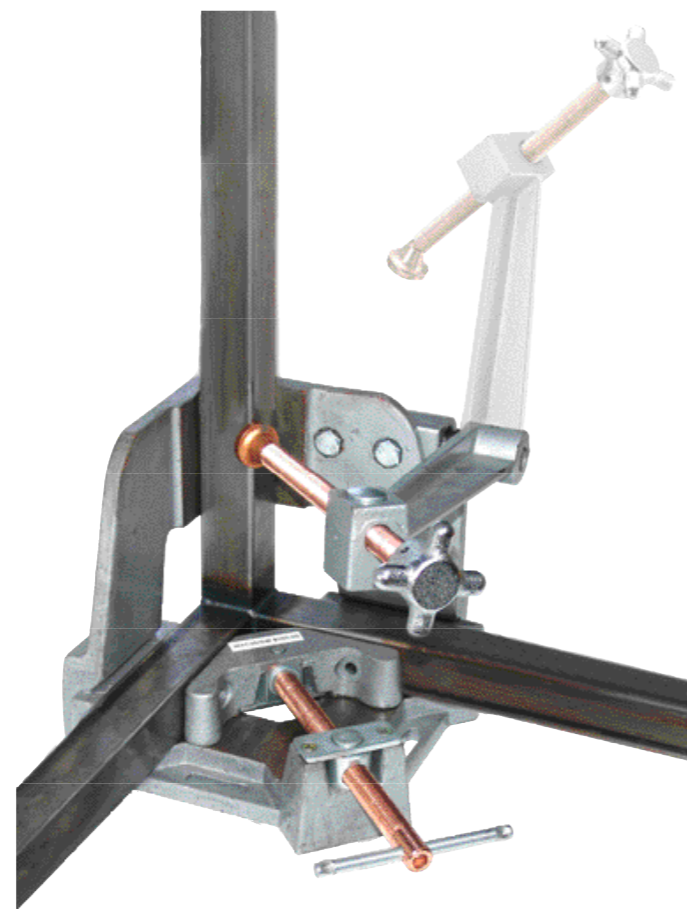

Part No.	Mitre Joints (A)	Jaw Length (B)	T-Clearance	Jaw Height (D)
WAC35-SW	95 mm	122 mm	62 mm	35 mm
WAC45-SW	121 mm	135 mm	100 mm	57 mm

Magnet Rest Blocks to Suit 3-Axis Clamps (Pair)



**StrongHandTools**  
Better Tools. Better Price.

### WELDERS UNIVERSAL VISE DUAL VISE MODEL

Clamp stock of different thicknesses at multiple angles. Patented Quick Acting Button for FAST setup! Magnetic Blocks (included) to support long stock.

- Jaw Opening: 4" / 100 mm
- Jaw Height: 1-3/8" / 35 mm
- Clamp round and square tubing, angled and flat stock at 5° to 180°.
- Copper plated screws with Quick Acting Buttons.
- Individual Angle Clamps easily swivel on the fixture base

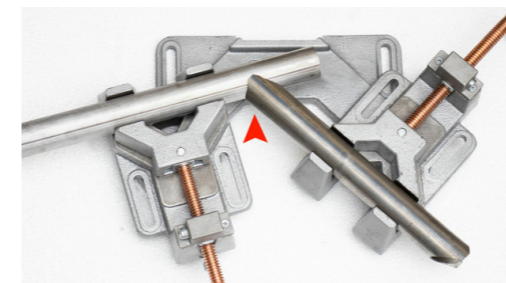
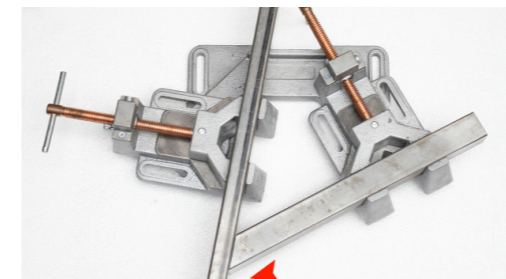

Part No.	Description
WAV200	Stronghand Dual/Duo Vice
WAS100	Stronghand Single Vice

NEW

WAV 200 DUAL VICE

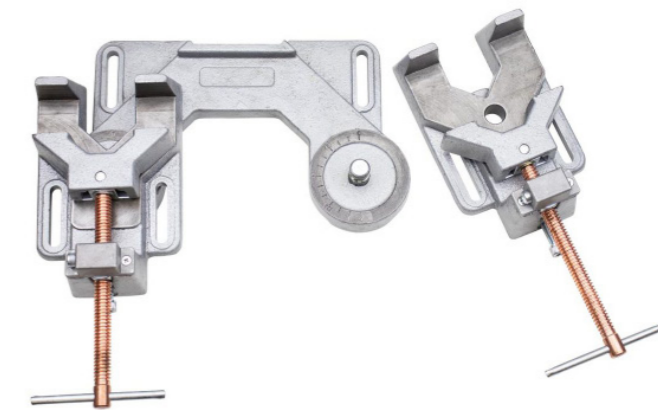

NEW

WAS 100 SINGLE VICE

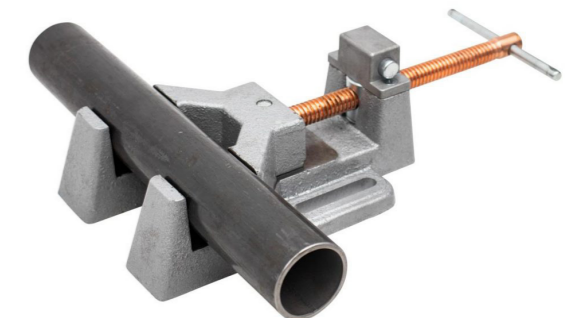

**MORE STRONGHAND PRODUCTS TO COME!**

## INSIDE / OUTSIDE ADJUSTABLE MAGNETS

### MLD SERIES 90° MAGNETS

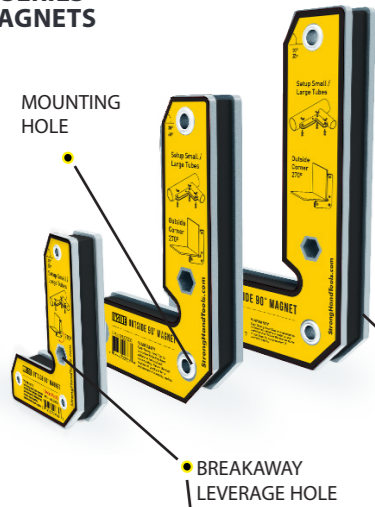

### MLA SERIES ADJUSTABLE MAGNETS

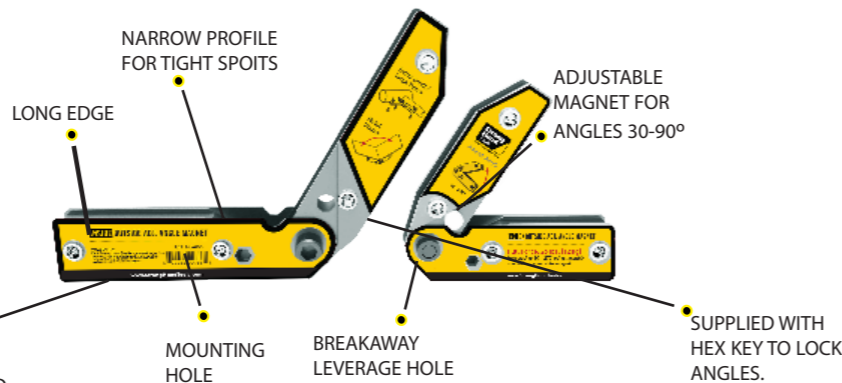

Hold stock from the outside, leaving clearance for inside welds, or hold stock from the inside for outside welds.

- Hold and position sheet metal, round pipes, square, angled or flat stock.
- The Inside / Outside Angle Magnets are constructed from two independent rectangular magnetic magnets for consistent, undiminished magnetic force when both sides are attached to workpieces.
- Use mounting holes to link two magnets together for use as fixturing elements.
- Use hex hole on magnet for breakaway leverage.

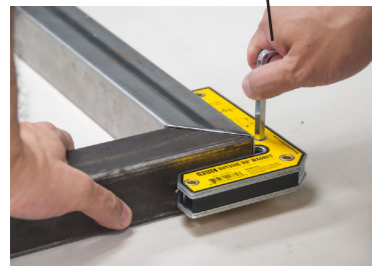

Comes with HEX KEY

Part No.	Angles	Height	Width	Thickness	Mag. Pull Force	Weight
MLDT350:	Set of 2 : Contains MLD300 + MLD500 ( 1 of each)					2.31 lbs. (1 kg)
1pc MLD300	90° (30°, 60°)	3" (75.5 mm)	2" (52 mm)	0.55" (14 mm)	20 lbs. (9 kg)	
1pc MLD500	90° (30°, 60°)	5" (125 mm)	3.35" (85 mm)	0.55" (14 mm)	33 lbs. (15 kg)	
MLD600	90° (30°, 60°)	6" (165 mm)	4.33" (110 mm)	0.79" (20 mm)	40 lbs. (18 kg)	1.61 lbs. (0.7 kg)
MLA450	30-270°	4.7" (120 mm)	4.7" (120 mm)	0.72" (18 mm)	26 lbs. (12 kg)	0.86 lb. (0.4 kg)
MLA600	30-270°	6" (156 mm)	6" (156 mm)	0.79" (20 mm)	33 lbs. (15 kg)	1.5 lbs. (0.7 kg)

## MAGTAB MAGNETS

The better, faster way to hold tabs in place for tack welding!

Hold tabs, or any small metal pieces, parallel or perpendicular to the substructure.

The Adjustable Magnetic V-shape base adjusts for different shapes: round, flat, angle metal surfaces  
MagTab JUMBO MNT15.



Part No.	Dimension	Pull Force
MFT10	100 mm x 76 x 32	8 kg
MFT17	111 mm x 73 x 38	8 kg
MNT15	132 mm x 114 x 71	16 kg
MFT12	Symmetric Mag tabs	(L&R Facing)
MTH20	Combo Pack	Square / Round

## MAG-HOLD & MAG-REST V-PAD KITS

Handy accessories for holding of round, flat, and square parts in light duty substructure applications.

Each V-Pad contains 4 magnets.

MVDF44 - Mag Hold Kit

Magnets on both pad face and the bottom.

MVDF42 - Mag Rest Kit

Magnets on the bottom only.



Part No.	Pull Force
MVDF44	8 kg
MVDF42	4 kg

## DUAL SWITCH MAGNET SQUARES & ADJUST-O MAGNET SQUARES

The fast & easy way to hold metal workpieces at 45° & 90°.

Turn the magnet Off when setting up, turn On when you're ready to work. Fast and safe set-up!

Ideal for round and square tubing, angle, and flat stock.

MSA53 multi angle: 30°, 45°, 60° & 90°



Part No.	Pull Force	Dimension
MSA46-HD	40 kg	111 mm x 95 x 29
MSA48-HD	75 kg	152 mm x 130 x 35
MSA53-HD	65kg	152 mm x 130 x 35

For professional jobs that demand strong hold down forces.

Hold flat and round metal work pieces. Two On/Off switches for independent operation.

Precision machined flat and V-surfaces are ideal for round and square tubing, angle, and flat stock.



Part No.	Pull Force	Dimension
MS2-80	55 kg	152 mm x 152 x 38
MS2-90	120 kg	197 mm x 197 x 48

## ADJUST-O ANGLE MAGNET

Adjustable from 30° - 275° with two On/Off switches.

Precision machined flat surfaces and nickel/chrome body.

V-Groove surfaces securely hold round and square tubing, angle, and flat stock.



Part No.	Pull Force	Dimension
MAV120	50kg	197 mm x 197 x 95

## STANDARD MAGNET SQUARES

For professional jobs that demand strong hold down forces. Hold flat and round metal work pieces.

Precision machined flat and V-surfaces are ideal for round and square tubing, angle, and flat stock.



Part No.	Angles	Pull Force
MS346C	30°, 60° 45°, 90°	40 kg

## MINI MAGNET SQUARES

Holding at multiple angles while soldering, brazing, and welding at 30°, 45°, 60°, and 90°.

The compact size makes it easy to pack, store, and carry.

Dimensions 59 x 51 x 16mm



Part No.	Description	Pull Force
MS346AT	Twin Pack	10 kg
MS346AK	6-Pack	10 kg

## XYZ MINI MAGNETS

Quickly and easily set-up 2 or 3-Axis workpieces.

Re-position, while holding. Tap or slide workpieces to fix positioning, without removing the magnet.

Magnetic face plate features two rare earth disc magnets for 3rd axis holding.



Part No.	Description	Pull Force
MST348	Twin Pack	10 kg

## CORNER MAGNET

Create 90° corners by holding from the outside, providing you with an unobstructed area for inside tack welds.

One side corner "relief" provides clearance for tall lips.

Use the outer edges of the Corner Magnet for setting up materials at 60°.



Dimensions 83 x 95 x 16mm

Part No.	Description	Pull Force
MST327	Twin Pack 90° & 60°	14kg

## STRONG GRIP PLIERS

The Easiest to GRIP, ADJUST & RELEASE.



### C-JAW PLIERS WITH HAMMER HEAD

Unique design provides a convenient hammer when you need it, where you need it!

Part No.	Opening	OAL	Weight
PCH10	40 mm	300 mm	0.6 kg

## ADJUSTABLE, LARGE CAPACITY BIG-MOUTH PLIERS

### 4 Adjustment Slots

- Adjust instantly to hold large or small workpieces.
- Unique crank handle for FAST opening, closing, adjusting.
- Serrated jaw surfaces for extra gripping power.
- V-Notch on top jaw for holding small parts.
- Long jaw [2-1/4" / 64 mm] for extra capacity and greater versatility in workhold. Keep this versatile tool on hand for fast clamping in a variety of jobs!



COPPER Grounding Big Mouth pliers with copper jaw and ribbon

### BIG MOUTH PLIERS

Part No.	Max. Opening	Throat Depth	OAL	Weight
PAJ100	80 mm	64 mm	250 mm	0.7 kg
PAJ207 Copper Grounding	80 mm	64 mm	250 mm	1 kg

### C-JAW PLIERS

Machined curved jaws with serrated teeth tightly grip round stock as well as a variety of shapes.

Part No.	Opening	OAL	Weight
PCJ50	1"(26 mm)	7"(180 mm)	0.4 lb.(0.2 kg)
PCJ70	1.6"(40 mm)	9.6"(245 mm)	0.8 lb.(0.4 kg)
PCJ100	1.6"(41 mm)	12"(300 mm)	1.2 lbs.(0.6 kg)
PCJ120*	2.2"(55 mm)	14"(360 mm)	2.0 lbs.(0.9 kg)

### LOCKING CHAIN PLIERS

Clamp odd shaped multiple items. Adjust tightness with crank handle. Replaceable chain available in 24", 36", and 48" lengths.

Part No.	Chain Length	Holds Pipes	Weight
PFC1024	600 mm	165 mm	0.9 kg

### REPLACEMENT CHAIN

Part No.	Chain Length
PXC36	910mm
PXC48	112cm

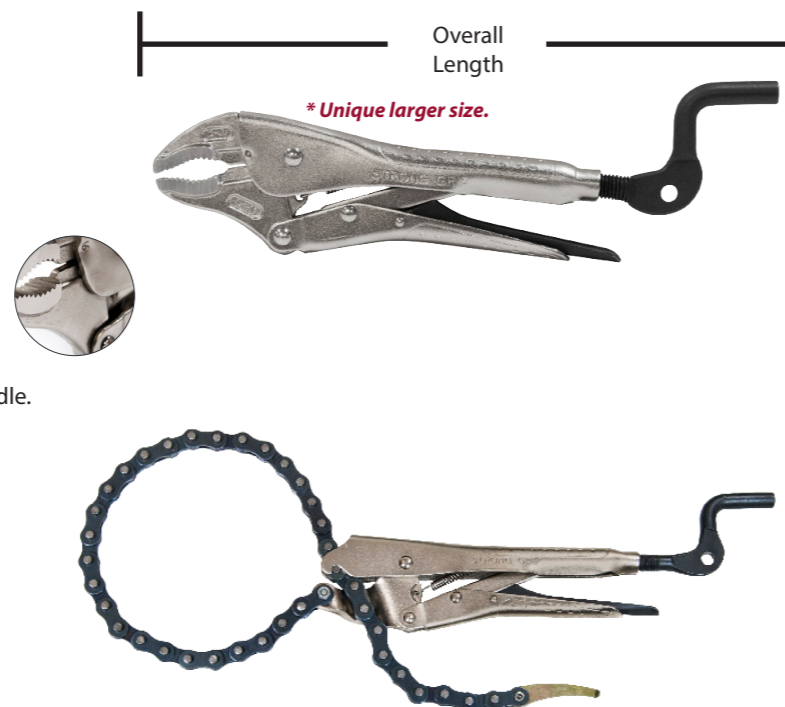

## STRONG GRIP PLIERS

**StrongHandTools**  
Better Tools. Better Price.

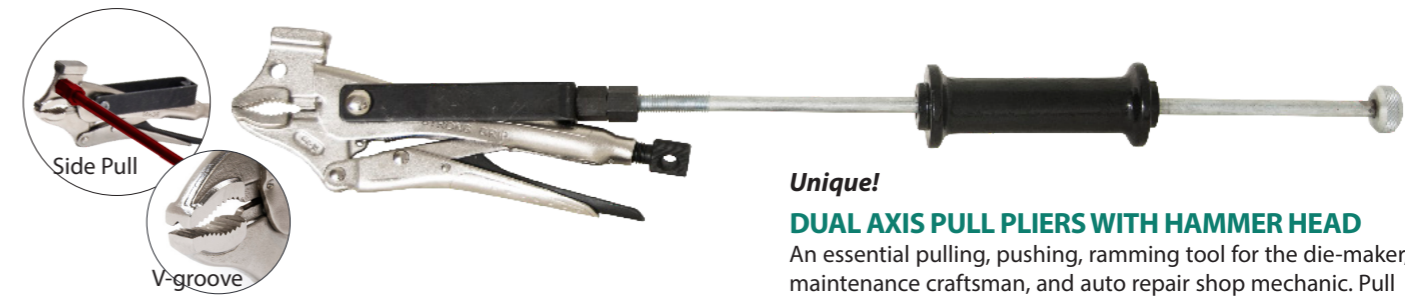

**Unique!**

### DUAL AXIS PULL PLIERS WITH HAMMER HEAD

An essential pulling, pushing, ramming tool for the die-maker, maintenance craftsman, and auto repair shop mechanic. Pull Rod mounts in the swing handle, or in the threaded hole for 2-axis pulling or pushing.



SELF ALIGNING PULL BAR

Part No.	Opening	OAL	Weight
PPD100	1.6" (40 mm)	28" (715 mm)	1.7 lbs. (3.8 kg)

**Unique!**

### ECONOMY PIPE PLIERS

Large Capacity (3"/75 mm)! Holds round, square, flat or angled. The large (1.5" / 38 mm dia.) swivel pad clamps at multiple angles.

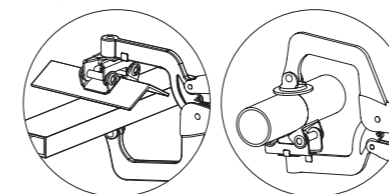

### U-PRONG PLIERS

Wide U-Shaped jaw for workpiece visibility, weld access, secure holding.



### SHEET METAL PLIERS

Wide, robust contact plates for getting a firm hold on sheet metal.



### LONG NOSE PLIERS

Long, slim nose for access in tight, narrow, hard to reach areas.



Part No.	Opening Round / Square	OAL	Weight
PVS100	up to 3" (75 mm)	14" (360 mm)	2.2 lbs. (1.0 kg)

Part No.	Opening	OAL	Weight
PUP90	2" (50 mm)	11" (275 mm)	1.3 lbs. (0.6 kg)
PUP100	3" (80 mm)	13.4" (340 mm)	1.9 lbs. (0.9 kg)

Part No.	Parallel Opening	OAL	Weight
PDB80	0.4" (10 mm)	10" (250 mm)	1.2 lbs. (0.5 kg)
PDB90	0.6" (15 mm)	12.6" (320 mm)	1.7 lbs. (0.8 kg)

Part No.	Parallel Opening	OAL	Weight
PLN50	0.2" (5 mm)	8" (205 mm)	0.4 lb. (0.2 kg)
PLN90	0.2" (6 mm)	10.6" (270 mm)	0.9 lb. (0.4 kg)

## LOCKING CLAMPS

Made of heat treated steel and nickel/chrome plated for strength and durability. Updated features help you work quickly, safely and efficiently.

### Round Tip



PR115

### Swivel Tip



PR115S



PR18S

## MULTI-PURPOSE PLIERS

One swivel pad spindle and a fixed head spindle for flexible clamping. Threaded jaw holes allow addition of accessories.

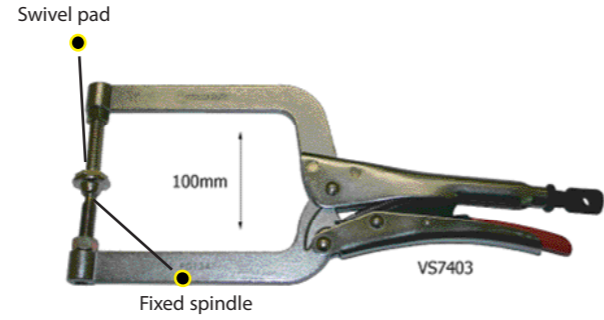

Part No.	OAL	Throat Depth	Opening	Thread
PG622	150mm	50mm	64mm	M8
PG114M	280mm	89mm	102mm	M10
PG134	330mm	140mm	102mm	M10

### PGA20M

ADJUSTABLE REACH ARMS WITH TOP AND BOTTOM ADJUSTABLE SPINDLES



### PGA20S

ADJUSTABLE REACH ARMS WITH TOP AND BOTTOM FIXED JAW



Part No.	OAL	Throat Depth
PGA20M	585-740mm	350mm, 405, 460, 510
PGA20S	585-740mm	350mm, 405, 460, 510

Part No.	OAL	Throat Depth	Opening
<b>Round Tips</b>			
PR6	165 mm	46 mm	56 mm
PR115	280 mm	83 mm	102 mm
PR18	450 mm	254 mm	114 mm
<b>Swivel Tips</b>			
PR6S	165 mm	46 mm	56 mm
PR115S	280 mm	83 mm	102 mm
PR18S	450 mm	254 mm	114 mm

## PIPE PLIERS

The convenient way to hold round or square tubes for butt welding.

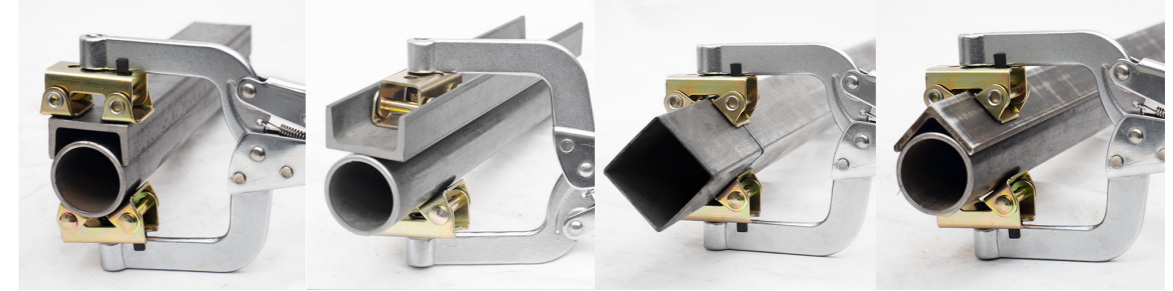

Part No.	Description	OAL	Throat Depth	Min/Max Dia	Thread
PG622V	6" pliers, fixed V pads (2 x XDV)	152 mm	50 mm	25 mm - 50	M8
PG634V	8-12" pliers fixed pads (2 x XDV)	215 mm	76 mm	50 mm - 80	M8
PG635V	Adjustable Top V-Pad Spindle large V pads (XFV & Xfv2)	215 mm	76 mm	40 mm - 64	M8
PG114VM	11" pliers fixed large V pads	280 mm	89 mm	40 mm - 64	M10

## THE GRASSHOPPER - WELDING FINGER CLAMP

- Use the "Welding Finger" to steady parts for tack welding! Safe and convenient!
- Steady small parts, such as: bolts, nuts, and thin plates for tack welding at odd angles with full welding clearance.
- No other device can do what the Grasshopper does!

### MAGNETIC GRASSHOPPER

- One-piece, fully adjustable clamp is easy to place and remove.
- Hold steel stock in the vertical position with self-adjusting holding pressure
- Use in tight, hard-to reach spaces with no obstruction for tack welding.
- Place the adjustable magnetic base on round, square, flat or angled surfaces.

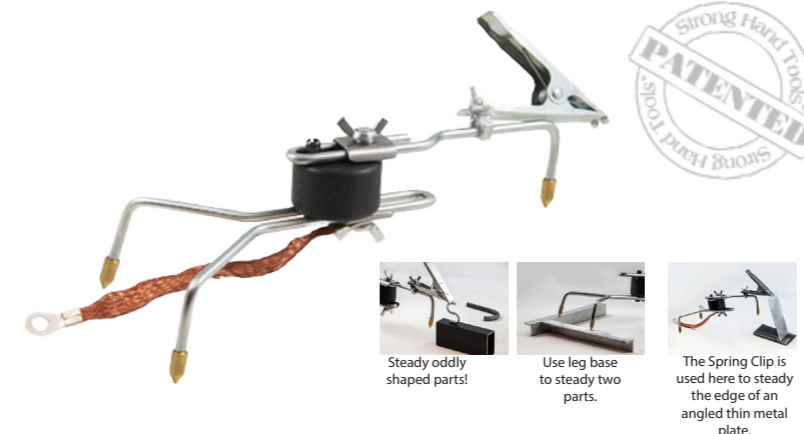

Steady oddly shaped parts!

Use leg base to steady two parts.

The Spring Clip is used here to steady the edge of an angled thin metal plate.

Part No.	Includes	Max OAL	Width x Height	Weight
AGH130P	Spring Clip, Grounding Ribbon & 3 Brass Tips	300mm	114-102mm	.69kg
AGH200	Small Magnetic V-Pad, Spring Clip, Brass Tip	190mm	64-89mm	.23kg
AGH230	Large Magnetic V-Pad, Spring Clip, Brass Tip	200mm	102-102mm	.45kg

## CORNER PLIERS - ANGLE CLAMPING TOOLS

Fast, Precise and Affordable Clamping Tools for corners and T-Joints

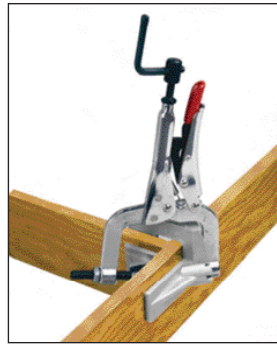

### PL Series

Ideal for quick hold & release on wood, metal & synthetic materials.

A helping hand to stock firmly at right angles while creating or repairing permanent joints

Part No.	Throat Depth	Max Capacity
PL634	76mm	32mm

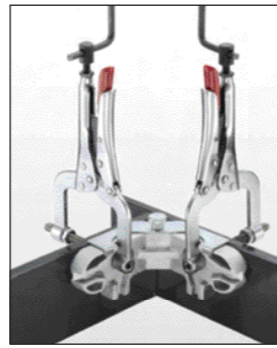

### PT Series

Retractable plate for edge alignment V-Grooves for holding round pieces.

Ideal for holding two pieces of different thicknesses that require individual adjustments.

Part No.	Throat Depth	Max Capacity
PT634	76mm	76mm



### 90° Corner Clamp

The adjustable top bracket is affixed to a Spring-Loaded arm for quick set ups.

Large opening accepts 50mm tubes.

Can be used with PG634V Pipe Pliers for holding 3-axis workpiece

Part No.	Throat Depth	Max Capacity
UDL365	76mm	50mm

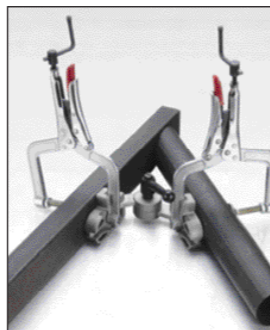

### PA Series

Adjustable from 30° - 275° using the locking handle.

Join round & flat workpieces, or materials with different thicknesses.

Part No.	Throat Depth	Max Capacity
PA634	76mm	76mm

## BENCH-MOUNT PLIERS HOLDER

Convenient storage, or Hands free use

Holds in Vertical & Horizontal positions

Wing Nuts on both Vertical and Horizontal positions lock pliers in place

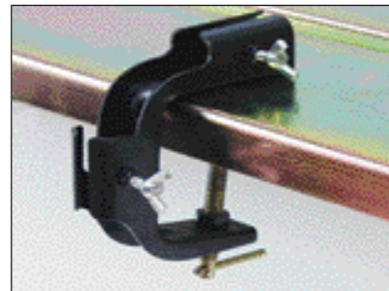

Part No
PB11

## PANEL CLAMPS

Magnets hold clamp parts and panels together.

Magnets in the keeper plate and the clamp body hold your panels in position for a speedier, & more efficient setup.

Turn the Spring-loaded screw to adjust the opening to accept panels of different thicknesses [max 5mm]

Part No	Description
MPC12	Twin Pack



## EXPAND-O PLIERS

Unique, Reverse action clamping pliers, The jaws move in the opposite direction to push against two surfaces

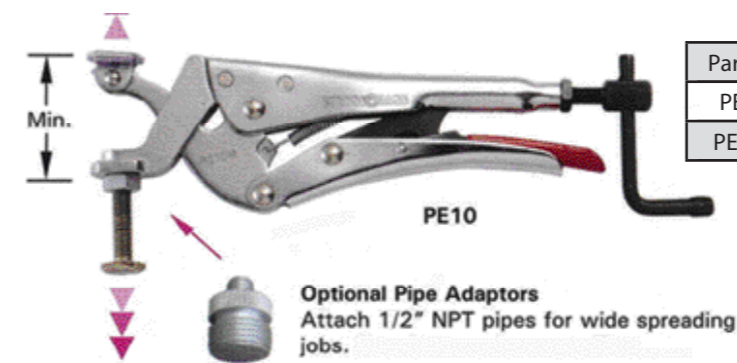

Clamping				
Part No.	OAL	Pressure	Min	Stroke
PE6M	165mm	230kg	25mm	19mm
PE10M	255mm	410kg	35mm	35mm

Pipe Adaptors.	
Part No.	For
XDJM	Suits PE6M
XFJM	Suits PE10M

## TABLE MOUNT LOCKING C-CLAMPS

Mounts directly to any work bench, drill press and fixtures, Mounting base hole accepts standard M8 bolts and uses push down action to hold your workpiece securely.

Use the Crank-Handle for pressure adjustment, Rapid lock and release. Ideal for repetitive clamping.

Part No
PT09



## DRILL PRESS CLAMP

Drill Press Clamps quickly lock and release, making them ideal for repetitive clamping. Secure the Drill Press Clamp to any surface, up to 25.4 mm thick.

M12 x 38 mm Stud and convenient, ergonomic zinc plated knob. Use the handy crank handle to: increase torque; pre-set the Pliers opening for repetitive clamping applications and loosen the Pliers before unlocking.

Part No
PTD09

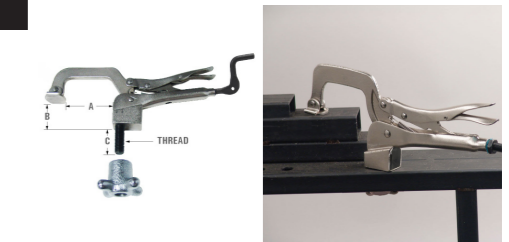

## SNAKE MAGNET

The Third Hand—Holds, Bends, Twists

Comes complete with 2 magnetic pads and 1 spring clamp

450mm Flex Cable links the magnet and spring clamp

Can be used to hold small parts, tools, & lights

Part Number	Pull Force
MFC312	8kg
MFC318	10kg



**Adjustable Magnetic V-Pad**  
Adjusts for different shapes: round, flat, angle metal surfaces



## TORPEDO MAG-LEVELS

The use-anywhere, view anywhere compact magnetic level

4 strong magnets allow hands-free use on metal surfaces

V-Groove on one side for pipe and conduit work

Robust, solid anodized aluminium body

Dimensions 178mm x 32mm x 25mm

Part No.	Angles
LM3723	0°, 45°, 90°

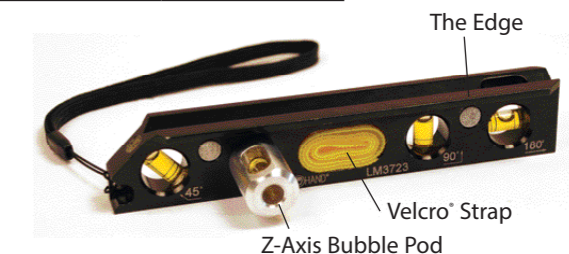

Easily mount onto metal surfaces.

Rotate the Bubble Pod for 2-axis leveling.

Attaches to wood post.

## POWERBASE GROUNDING MAGNET

Power through your grounding applications  
The Powerbase Grounding Magnet sets up quickly and easily. Start grounding instantly!  
Powerful rare earth magnet delivers heavy duty holding power  
The "V" machined surface grips round parts  
The copper connector stud is located on top and allows for a full 360° cable rotation.  
Rugged, compact steel housing for a fast and safe ground, even in tight spots!

Part No.	Amperage	Dimension mm	Magnetic Force
GM203	300A @ 60% Duty Cycle	50x50x64	34kg
GM205	500A @ 60% Duty Cycle	50x70x64	50kg



## GROUND HOG CLAMPS & PLIERS

High clamping pressure improves arc stability and reduces power consumption  
Prevents current restriction and allows a complete transfer of the electrical current  
Controls the electrical current by isolating the contact surface and the cable connection  
Get a smooth, continuous arc with no fade, and no heat transfer while improving cable life, and reducing power consumption.  
The Ground Hog  
The groove design on the copperhead seals out weld spatter and reduces particle buildup.  
Side screw provides a secure cable connection  
Ground Hog body rotates for cable positioning

Part No.	Max Opening	Throat Depth	AMPS Rating
<b>CLAMPS</b>			
GF1751	135mm	120mm	550
<b>PLIERS</b>			
GP1530	55mm	70mm	300
GP950 (GP2850)	70mm	80mm	450
GC5010	Ground Hog Spare Contact		



## GROUNDING CLAMPS

Clamping & Grounding at the same time  
Consistently rated at 300 AMPS  
Solid, insulated copper U-channel rotates for easy access and can attach to round / odd shaped parts

Part No	Amperage	Clamping Pressure
GB428	300A	100kg



## STRONG GRIP GROUND CLAMP

The most efficient Ground Clamp on the market  
Exclusive design copper contact grips round or flat section  
Insulation prevents shorting to plier frame  
Threaded stud at the side for attaching ground cable fitted with 8mm field lug  
Speed crank & adjustable clamp spindle  
Suitable for welding applications up to 350 amps

Part No
GP628

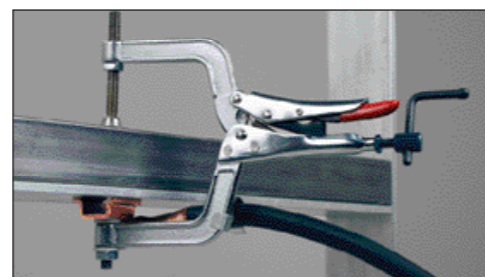

## MAGTAB MAGNETS

The better, faster way to hold tabs in place for tack welding!  
Hold tabs, or any small metal pieces, parallel or perpendicular to the substructure.

The Adjustable Magnetic V-shape base adjusts for different shapes: round, flat, angle metal surfaces  
MagTab JUMBO MNT15.

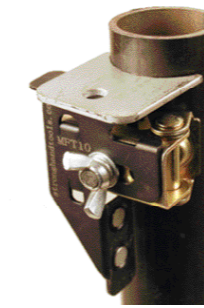

Part No.	Dimension	Pull Force
MFT10	100 mm x 76 x 32	8 kg
MFT17	111 mm x 73 x 38	8 kg
MNT15	132 mm x 114 x 71	16 kg
MFT12	Symmetric Mag tabs	(L&R Facing)
MTH20	Combo Pack	Square / Round

## MAG LEVEL

The only magnetic level with the On/Off switch.  
Holds securely to round and flat surfaces.  
Three vials for 0°, 45°, 90° reading.

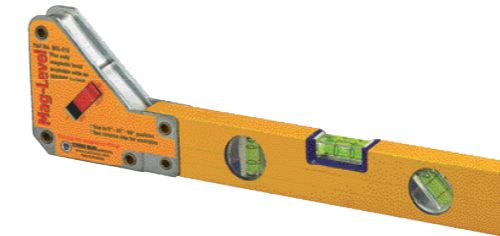

Part No.	Angles	Dimension	Pull Force
MSL-316	45°, 90°	102 mm x 406 x 25	30 kg

## HANDI-HAMMER

The unique dead blow tapper.  
One steel end and one soft face.  
Eliminates bounce back and increases impact.



Part No.	Dimension	Weight
CH-10	40 mm x 127	10 oz
CH-14	45 mm x 133	14 oz

## MAG-HOLD EXTENDABLE ARM

Position and hold steel stock in welding and fabrication.  
Telescoping mounting bar adjusts from 178 to 254mm in length.  
Loosen the center joint in the mounting bar to "fold up" the MagHold™ for different workholding configurations.  
Adjustable magnetic v-pads at each end hold stock of different shapes: round, flat, angled.

Part No.	Pull Force	Weight
MHF608	8 kg	0.6 kg



## NOMAD ECONOMY WELDING TABLE

Fully Adjustable. Easily Movable. Very Affordable.  
Three 28mm slots in the tabletop allow for insertion of clamps to reach any point on the table.  
Tabletop tilts to three positions: Horizontal, 30°, and folded.  
Two retractable, perpendicular steel guide rails can be used as guides, stops, or clamping edges.  
Height can be adjusted from 66cm to 81 cm.  
Tabletop size 760mm x 510mm  
Kit includes : 2 x MagSpring Clamps UB45, 1 x Multi-Angle Magnet MS346C, 1 x Mini-Magnet MS346A, and 2 x Adjustable Magnetic V-Pads XDV4



Part No.	Description	Load Capacity	Weight
TS3020	Table	160 kg	20 kg
TSK104M	7 piece kit		22kg
TSL30	Connector Plate	160 kg	7.4 kg

## READY REST

### You don't work in one fixed position, so neither should your torch rest.

The height and angle adjustable ReadyRests attach securely to any steel surface for safe and convenient holding of your torch and cable for full access while you work. The unique adjustable cable hanger provides cable control for safety, and ease of handling. Store your torch on the ReadyRest to prevent damage and create a clean, organized work area.

**"Ready When You Are"**

### MIG GUN RESTS

MRM200 is Height & Angle Adjustable and features an angled anti-spatter Gel Pot

Part No.	Description	Height	Weight
MRM100	MIG Torch Rest with Cable Hanger & Accessory Plate	150 mm	0.95kg
MRM200	MIG Torch Rest with Cable Hanger & Accessory Plate, Adjustable Height	180 - 310mm	1.6kg

MRM100



MRM200



### TIG GUN RESTS

DEEP BEND for extra-secure torch holding. Rounded Edges prevent scratching. Adjustable Cable Hanger holds cable "slack" for safety and reduced wrist fatigue. MRT200 is Height Adjustable. MRT50 is the unique table edge mount model.

Part No.	Description	Height	Weight
MRT100	TIG Torch Rest with Cable Hanger	190 mm	0.95kg
MRT200	TIG Torch Rest with Cable Hanger & Adjustable Height	180 - 310mm	1.3kg
MRT50	Table Edge Mount TIG Torch Rest with Cable Hanger	140mm	0.50kg

MRT100



MRT200



MRT50

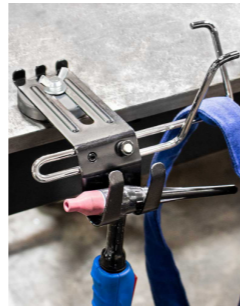

### UNIVERSAL REST

The Universal Rests hold your MIG or TIG Torch, or Electrode Holder. The Stainless Steel housing is angle-adjustable, with an adjustable keeper plate inside for secure, customizable holding.

Part No.	Description	Height	Weight
MRD80	Universal Rest with Cable Hanger	151 mm	1.1kg
MRD90	Adjustable Height Universal Rest with Cable Hanger & Accessory Plate	178 - 305mm	1.8kg

MRD80



MRD90



### POWER GRINDER RESTS, C-CLAMP BASE MODEL W/ VERTICAL MOUNTING PLATE

Store your Grinder and all accessories on one convenient, compact, portable rest for easy access. No more searching for wrench or spare discs. Holds most 5" Grinders. Also holds keys & spare discs.

Part No.	Description	Weight
MGK53	Grinder rest C-clamp	1 kg
MGH45	Grinder rest magnetic base	1.1kg

MGK53



MGH43

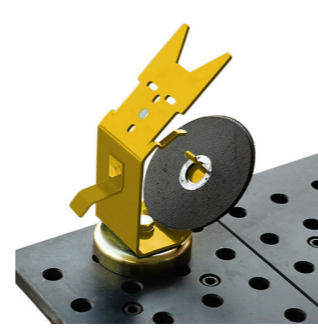

### ARM & WRIST REST

#### ARA18 - Fully articulated Arm Rest.

Fully adjustable Arm Rest with fully articulated arm, supports your extended arm while working. Steady your arm or hand, for greater weld control and reduced fatigue. The 2-section Articulated Arm is height adjustable [slide up or down the support column] and swivels quickly and easily for work in precise locations.

The comfortable, generously sized arm cup turns in a 360° arc for complete freedom in positioning, and instant re-positioning. Place the sturdy, anti-tipping, magnetic base plate on any steel surface and level by adjusting the two leveling bolts.

#### ARW16 - Fully Adjustable Wrist Rest

The Rest Bar is height adjustable [slide up or down the support column]. Place the sturdy, anti-tipping, magnetic base plate on any steel surface and level by adjusting the two leveling bolts. For space-saving storage, remove the Rest Bar from the adjustment column for vertical docking. An important addition to any welding setup. Steady your wrist for accurate welding and greater work quality with less fatigue.

Part No	Description	Arm Height Range	Arm Reach	Weight
ARA18	Articulated Arm Rest	150 - 380mm	0 - 320mm	2.2kg
Part No	Description	Rest Bar Height Range	Rest Bar Length	Weight
ARW16	Adjustable Wrist Rest	0 - 470mm	280mm	2.6kg

ARA18

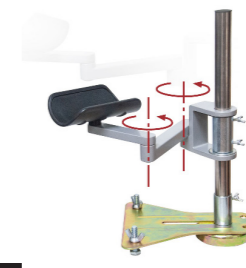

ARW16

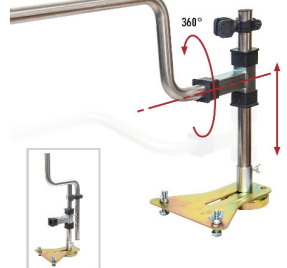

### A-FRAME HD MAGNET

New for sheet metal and large stock holding. Hold large workpieces in the upright position. Each magnet has an independent ON / OFF switch. Machined flat and V-faces hold round, square, flat, and angled stock.

330 mm x 330 mm x 32mm  
Maximum Pull Force 120 Kg

Part No
MS2-300



### HALF CLAMPS

#### The Efficient, Safe Way to Align Materials

The DOG & WEDGE methods of material alignment are messy, time consuming and unsafe. Align materials in the fabrication of water tanks, bulkheads, deck sections, flat plates, etc. Ideal for fabricators, repairmen, ship and barge builders.

Part No
VHC15

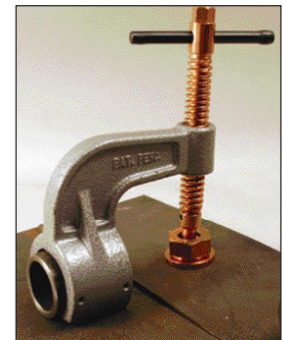

### SIDE CLAMPS

Build push-action clamp to custom heights. Fit standard 38mm pipe or cut any length to the clamp body and base. Base can be bolt-mounted to the table.

Part No
VSC15



### NEW

### HOLD DOWN CLAMP

Part No.	Capacity	Weight
VHD30M	2-3/4" (70mm)	2LB / .9Kg

The 1/2" copper plated ACME spindle resists weld spatter, and the swivel tip makes quick contact with your workpiece.

Hold pipes by adding our Clip-On V-Pad (XDA2).

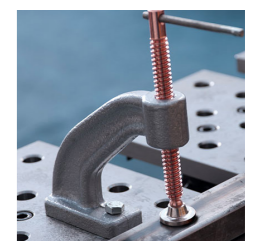
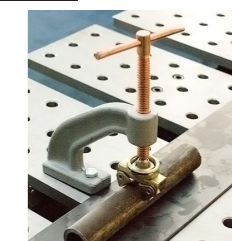

\*For further specifications please visit our website

## GAS CYLINDER RANGE



### GAS CYLINDER CART

This new CYLINDER CART allows you to safely lift, move, place and store heavy cylinders. The sliding Stainless Steel Keeper Bar holds the cylinder securely in place without the use of chains or straps.

Rugged round steel tube welded construction for strength and durability, with powder coated finish.

Wheels: 8" pneumatic wheels + 3" locking wheels for mobility and storage.

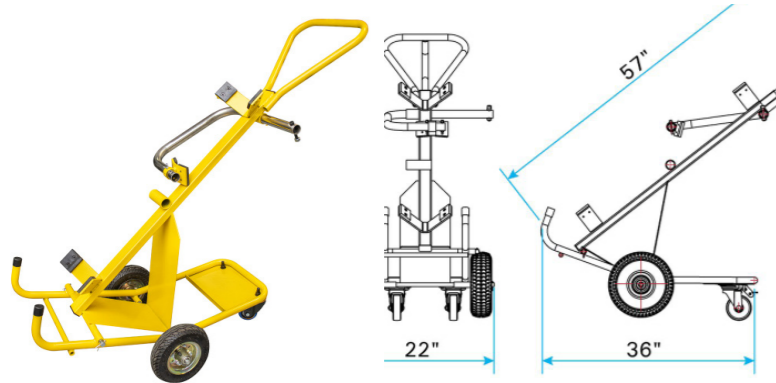

Part No.	Load Capacity	Cylinder Size	Unit Weight
GCC200	180kg / 400lb	215-230 (mm)	22kg / 48lb

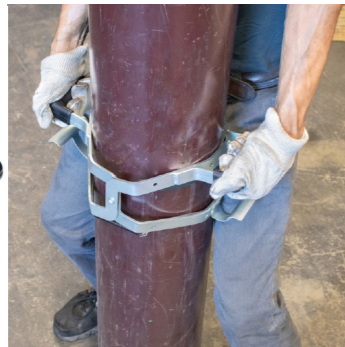

### GAS GRABBER

- Two handles for safe, two-person team lifting.
- 8-point cylinder contact and friction pads provide a positive, safe hold.
- Scissor-action handles automatically engage for secure lifting.

TO SUIT CYLINDERS 215-230mm or 8.5-9" diameter

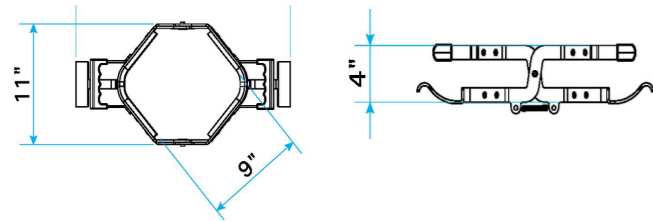

Part No.	Product Dimensions	Net Weight
GCL230	20" x 11" x 4"	3.17 kg

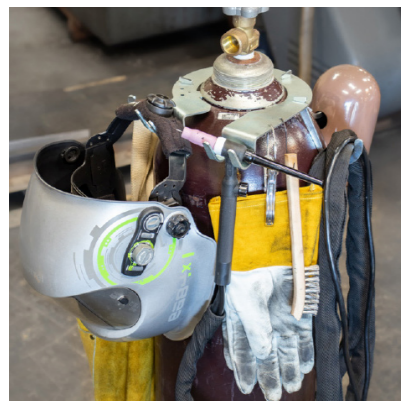

### GAS HOOK

Part No.	Product Dimensions	Net Weight
GCH140	9' x 7" x 4"	.70 kg

## ACCESSORIES

Standard V-Pads. Attach to pliers or clamps to hold round & angled workpieces

Part No	For Clamps	For Pliers
XDV	UD	PG622
		PG634
XFV	UE, UF, UG	PG114, PG134
		PG204, PGA20
XMV	UM, UP	-
XDVS [SS]	UD	PG622
		PG634
XFVS [SS]	UE, UF, UG	PG114, PG134
		PG204, PGA20
XMVS [SS]	UM, UP	-

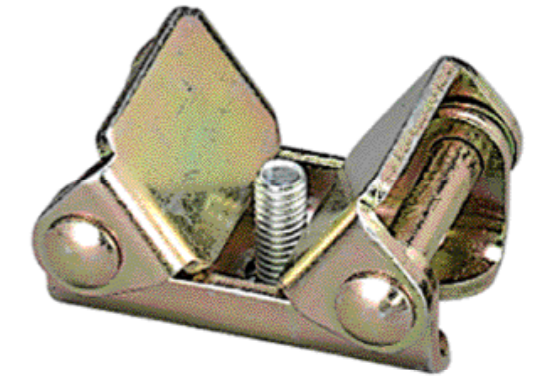

Clip On V-Pads

Part No	For Clamps
XDA2	UD
XFA2	UE, UF, UG
XMA2	UM, UP
XFA2S [SS]	UE, UF, UG
XMA2S [SS]	UM, UP



Screw-On V-Pads

Part No	For Clamps
XMA	UM, UP
XMAS [SS]	UM, UP

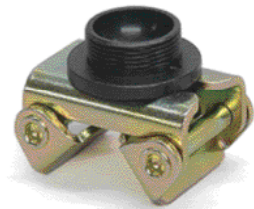

Extender Blocks. Attach to U-Clamps for Step over & Spreading applications

Part No	For Clamps	Size Thread D.L
XFBM	UE, UF, UG	M10. 30mm. 51mm
XMB2M	UM, UP	M10. 30mm. 51mm

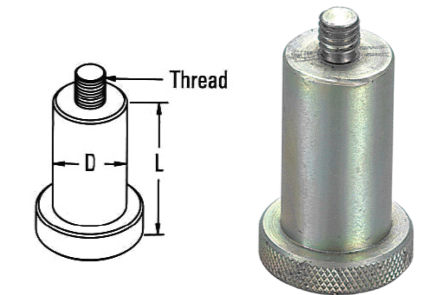

Sidekicks. Mount to U-Clamps for 2 axis horizontal clamping

Part No	For Clamps	Length & Stroke
XFSM	UF	111mm & 35mm
XGSM	UG	111mm & 35mm
XMSM	UM	111mm & 35mm

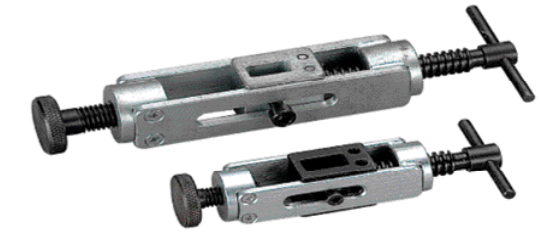

Bench Rests. Supports U-Clamps in standing position

Part No	For Clamps
XMU2	UM



Heavy Duty replaceable pads

Part No	Description
XMJ	Swivel pad assembly HD



## PIPE ALIGNMENT CLAMP

### TWO SIZES, THREE SIMPLE INSTRUCTIONS

#### PRESS - SLIDE - SET

The New Pipe Alignment Clamp with Quick-Acting Screw is a fast, accurate fit-up clamp with a rugged frame for use in the shop, or at the job site.

Get a well-balanced hold on the Pipe Alignment Clamp with the two wide Grip Plates while pressing the Quick-Acting Button. The threaded screw smoothly glides up and down for fast jaw opening and clamp removal after welding.

The long life clamp is made of double-walled powder coated steel. Align pipe for joining pipe to elbow, pipe to tee, or pipe to flange.

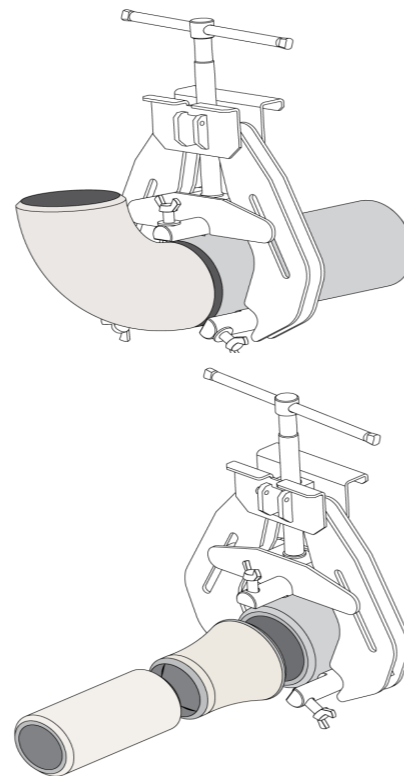

Part No.	Capacity	Weight
CPA60	2" ~ 6" (50 ~ 152 mm)	11 lbs. (5 kg)
CPA120	4.5" ~ 12" (114 ~ 305 mm)	17 lbs. (8 kg)



## PIPE FIT UP CLAMP

A compact, light weight, portable clamp for the quick fit-up of round pipes and flanges for butt welding.

Easy-to-Use design for the rapid, repeated loading and unloading of workpieces.

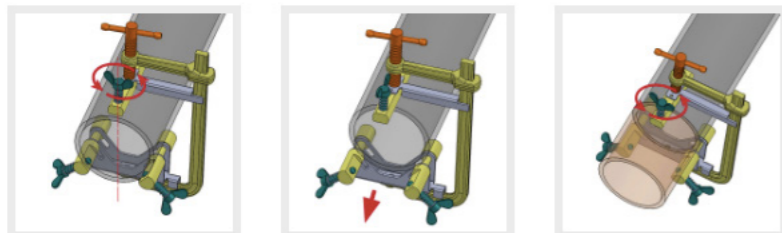

1. Set clamp screws for your pipe diameter.
2. Move clamp forward.
3. Place second pipe and tighten.



Part No.	Pipe Diameter Capacity	Clamp Rods Width	Overall Length	Weight
CPL45	50 ~ 100 mm	89 mm	241 mm	1.3 kg
CPL75	100 ~ 140 mm	89 mm	305 mm	2.1 kg



## NOGA GRANITE BASE STAND

NOGA Granite Base Stand and articulated holders with fine adjustment on top. NOGA Granite Base Stands are made with high quality and hardened granite. Due to its stability and ease of use, NOGA's articulated holders have become the most sought-after in the industry.

- Solid 3D articulated holder with central locking system with NOGA designed spring loaded bearing mechanism.
- Fine adjustment on top with universal swivel clamp.
- Holds 6mm, 8mm, 3/8" and dovetail.
- Fast and easy to set up gauges into required position.
- Black finished arms.

NEW



NEW

Part No.	Description
MT2000	Granite Base Stand & DG Articulated Holder
MT2100	Granite Base Stand & MG Articulated Holder

## NOGA V BLOCKS

**NOGA Heavy Duty V Block Magnet Sets**, including a choice of Noga holders, can help with the numerous challenges of the skilled operator of machine tools.

Utilized for general shop applications: securing & layout of items with various shapes, holding stock securely in place during light-duty operations such as boring, tapping, milling, drilling and grinding.

Noga is offering a selection of V Block Magnet sizes with either a NF or PH Holder.

Designed to hold dial and test indicators as well as other components.



Part No.	Description
VB1300	V Block Magnet (VB1002) 60x73x100 with Noga NF Holders (NF60103)
VB1100	V Block Magnet (VB1002) 60x73x100 with Noga PH Holders (PH3101)
VB1400	V Block Magnet (VB1004) 70x95x120 with Noga NF Holders (NF60103)
VB1200	V Block Magnet (VB1004) 70x95x120 with Noga PH Holders (PH3101)
VB1002	V Block Magnet Only (60x73x100)
VB1004	V Block Magnet Only (70x95x120)

**NF1021**

Unique 5 axis, 3 dimensional Holder  
Has unique patented 360 degree fine adjustment at the base.  
Central locking mechanism with NOGA designed spring loaded bearing.  
On/Off magnetic base 17 Kg/f.  
Holds test and dial indicator on 8mm, adaptor to 6mm and dove tail.



**NF1030**

Similar to NF1021 but with powerful 28 Kg/f permanent magnetic base.  
Can be mounted on flat as well as on curved surfaces.



**NF1022**

Test Indicator Holder arm for centering of workpieces  
Has universal fine adjustment. Will hold 6mm, 8mm, 3/8" dovetail



**NF1015**

Test indicator holder arm with 8mm diameter long stem.  
Most useful for centering holes on milling machines.



**HOLDING SYSTEM**

**ECONOMICAL HOLDER**

Features universal holder with unique 5 positions clamp. Will hold 6mm, 8mm, 3/8" stems. Has dovetail & screw for holding back lug. No fine adjustment

**Part No. MB1000**

Post 12 x 180mm  
Arm 10 x 165mm



**POST HOLDER FAB**

PH Holder with unique Fine Adjustment at the base. Universal swivel clamp for all dial and test indicators. Strong arm lock via 3 points clamp.

**Part No. PH2040**

Post 14 x 203mm  
Arm 12 x 185mm



**POST HOLDER FAT**

PH Holder with Fine Adjustment on top with Universal swivel clamp for all dial and test indicators. Strong arm lock via 3 points clamp.

**Part No. PH6800**

Post 18 x 350mm  
Arm 16 x 225mm



**HOLDING SYSTEM MAGNETS**

DG0040



DG0036

Part No	Description
DG0036	On/Off magnet 800 N M8 thread. 50 x 60 x 55mm
DG0038	On/Off magnet 1000 N M8 thread. 50 x 75 x 55mm
DG0039	On/Off magnet 1300 N M10 thread. 50 x 120 x 55mm
NF0037	On/Off magnet 320 N M5 thread. 30 x 40 x 35mm
DG1003	On/Off magnet 1000 N Multi thread. M6, 8, 10, 12 & 10x1.25
DG0040	Vacuum Base 350 N M8 thread 92mm diameter

**TOP ATTACHMENT FOR ARTICULATED HOLDERS**

Fine adjustment, Holds 6mm, 8mm, 3/8", dovetail

**Part No. FA1500**



**TOP ATTACHMENT**

No fine adjustment

**Part No. FA1100**



**HOLDING SYSTEM DIAL**

Dial Gauge **DG1000**  
Dial diameter 58mm, stem diameter 8mm  
Measuring range 0-10mm, graduations 0.01mm

Flat back



**POWER ARM**

Noga unveils its state of the art Hybrid articulated arms. They are stronger, bigger, longer and outperform all other three-jointed articulating arms in the industry. simply sophisticated

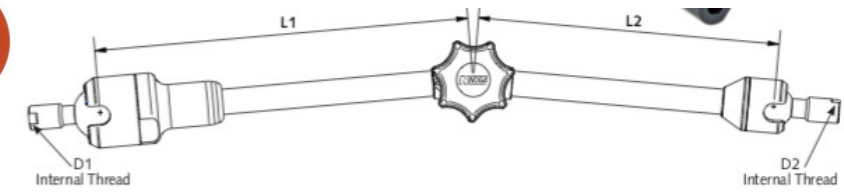

They can hold heavy components and other production accessories that require extend articulation mounts.  
New design combination of mechanical and hydraulic locking system, allowing to hold up to 25Kg.

Central locking system with spring loaded bearings. Black finish.



**DIAL GAUGE HOLDERS**



**Arm only**

DG60103	110mm	101mm
MG60103	133mm	113mm
MA60103	326mm	242mm



**DOUBLE FINE ADJUSTMENT HOLDER**

**BASE & TOP**

New Double Fine Adjustment:  
Top: universal swivel clamp.  
Bottom: Unique single direction.

Part No.	Bottom Arm	Top Arm	Magnet Force	Holder Bottom Thread
DG6160	110mm	101mm	800 N	Ext M8
MG6161	133mm	113mm	800 N	Ext M8

**ARTICULATED ARM HOLDERS**

Due to its stability and ease of use, the NOGA articulated holder has become a popular workshop tool for holding gauges and indicators.

Fine adjustment on top with universal swivel clamp

Holds 6mm, 8mm, 3/8", dovetail

Central locking mechanism with NOGA designed spring loaded bearing

Five axis holder

Powerful On / Off magnetic base

Instant fixation in any position

Fast and easy to set up gauges into the required position

Black finished arms

Part No.	Bottom Arm	Top Arm	Magnet Force	Magnet Part No.
NF61003	56mm	51mm	320 N	NF0037
DG61003	110mm	101mm	800 N	DG0036
MG61003	133mm	113mm	800 N	DG0036
MG71003	163.5mm	113mm	800 N	DG0036
MA61003	326mm	242mm	1300 N	DG0039



**HOLDER WITH FINE ADJUSTMENT AT BASE**

Unique single direction fine adjustment at base. Powerful on/off magnetic base. Unique central locking mechanism with Noga designed spring loaded bearing. Five axis holder. Easy to set up into required position. Black finished Arms.

Part No.	Bottom Arm	Top Arm	Magnet Force	Standard Clamp Dia
DG10503	110mm	101mm	800 N	8mm
MG10503	133mm	113mm	800 N	8mm

**Double Burr DB1000**

Double Burr, Hand Guard & 2 x N80 blades. Simultaneously removes burrs from both sides of sheet metal. Range 0-12mm. Use hardened blades, N80M42 on stainless steel.

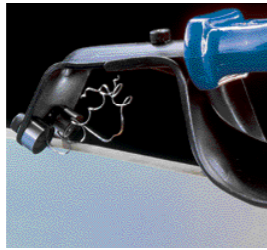

**Ceramic Double burr DB5000**  
Includes Hand guard & Ceramic blade



**Replacement blade CR5100**

**Universal Handy Chuck Holder PV1000**

Aluminium handle with non slip covering. A 3 jaw chuck helps with the quick and secure clamping of a wide variety of tools, blades and blade holders such as scrapers, countersinks, files etc. Hardness 58 HRC



**Adjustable Mini Ceramic Scraper CR4100**

Ceramic mini scraper ideal for surface cleaning, trimming, deburring and parting line deflashing of almost all plastics. special blade design for safety.

Includes:  
Ceramic Mini Scraper Handle - YT10004  
Ceramic mini-scraper blade - CR4500



**Cera-Cut Replaceable ceramic blade CR2000** for plastics & soft materials



Blade options - CR2200 CR2500

**BLADE HOLDERS For use with UNI Handle & NogaGrip 3**

- S Holder EL02003** Use with NG-3 Handle. Holds all S blades
- N Holder EL01002** Use with NG-3 Handle. Holds all N blades, straight or 90o
- SN Holder SN1000** Double sided & extendable holds both heavy (S & E) & light (N & B) duty swivel blades. Used with UH1000

**Rapid Burr RB1005** Rapid Burr RB1000 with S20 Blade packed in a card and blister. 12mm hexagonal aluminum handle.



**EZ Burr Pro EB1001** EB5000 Handle with HEAVY DUTY S10 blade used for aluminium, steel and plastic.



**EZ Burr Pro EB2000** EB5100 Handle with LIGHT DUTY N10 blade used for aluminium, steel and plastic.



**EZ Burr Pro EB4000** EB50003 Handle with D50 MINI blade used scraping, trimming, & deburring most material.



**Teddy Burr TB1000** Holds all "N" blades, easy to replace. Comes with handy pocket clip.



**NG Handles NOGA Grip handles** Ergonomic, Light-weight, Strong construction with Blade storage.

**NG1000 (NG-1)** Holds all 'S' blades

**NG2000 (NG-2)** Holds all 'N' blades

**NG3000 (NG-3)** Holds all 7mm blade holders



NG Handles

**UNI-Handle UH1000**

Holds: SN1000 & T120 Scraper



UH1000

**C Holder CH3000** Holds C12, C20 & C30 Countersinks.



**D Holder EL05003** Holds D50 & D66 blades.



**K Holder EL04003** Holds N70K, N80K & N90K



**Noga Burr 3 NG1003** NogaGrip Handle S10, S20, & S35 blades

**Noga Burr 5 NG1005** NogaGrip Handle S10, S20, S35, S101, S202 blades



**Super Burr NG3003** NG-3 Handle, S Holder S20, S30, & S100 blades

replaces "E" set



**Tele Burr NG3002** NG-3 Handle, N Holder N1, & N2 blades

replaces "B" set



**Countersink NG3100** NG-3 Handle, C-Holder C20 Countersink



**Scraper SC1000** UH1000 Handle, T120 Double ended triangular scraper



**Mini-Scraper NG3700** NG-3 Handle, D-Holder D50 triangular miniscraper



**Internal Scraper NG3710** NG-3 Handle, D-Holder D66 internal scraper



**KeyWay Burr NG3300** NG-3 Handle, K-Holder N80K blade

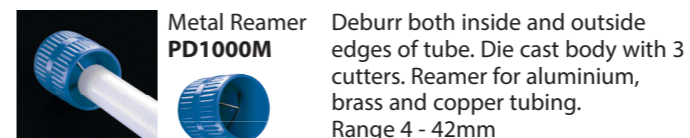

**Metal Reamer PD1000M** Deburr both inside and outside edges of tube. Die cast body with 3 cutters. Reamer for aluminium, brass and copper tubing. Range 4 - 42mm



**Liza Burr LB1000** UH1000 Handle, SN Holder N1, N2, & S10 blades



**Magic Burr 2 NG2002** NG-2 Handle, N1 & N2 blades



**"O" Ring Burr NG1100** NG-1 Handle, OR Blade



**Fixed RotoDrive NG1200** NG-1 Handle 10.4mm RotoDrive Countersink



**Thread Cleaner NG1600** NG-1 Handle, TC blade

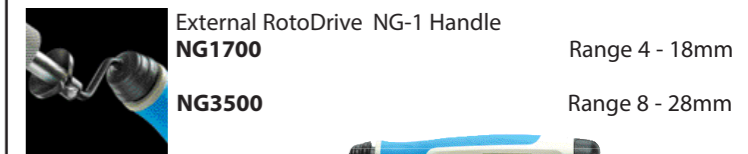

**External RotoDrive NG1700** NG-1 Handle Range 4 - 18mm



**External RotoDrive NG3500** NG-1 Handle Range 8 - 28mm

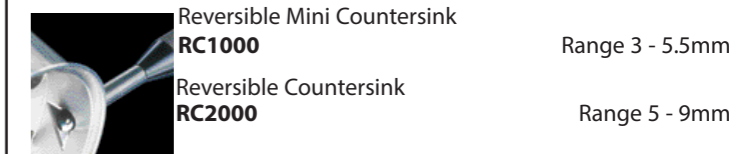

**Reversible Mini Countersink RC1000** Range 3 - 5.5mm

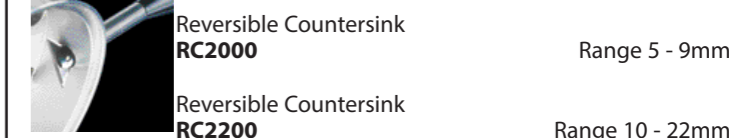

**Reversible Countersink RC2000** Range 5 - 9mm



**Reversible Countersink RC2200** Range 10 - 22mm



**Adjustable Scraper SC8000** 12mm Anodized Handle T80 scraper blade

**RETAIL DISPLAY PRODUCT BONUS KITS AND RETAIL DISPLAYS**



**S Promo Set NG8150**  
NG-1 NogaGrip Handle  
10 x S10 blades

**NG8250 Cobalt Set**  
Contains: NG-1 Handle  
20 x S100 Blades

**S Tele Set NG8350**  
NG-3 NogaGrip Handle  
5 x S10 & 5 x S20 blades

**N Tele Set NG8300**  
NG-3 NogaGrip Handle  
5 x N1 & 5 x N2 blades

**N Promo Set NG8000**  
NG-2 NogaGrip Handle  
10 x N1 blades



**LB1900 Kit**  
UH1000 Handle & SN1000 Holder with 5 x S10 & 5 x N1 blades

**NG1003**  
NOGA BURR heavy duty contains the NG1000 Noga grip handles & 3 HD blades S10, S20, S35

**RB1005**  
RB1000 Rapid Burr with S10 & S20 Heavy duty blades . Blister Packaging.

**EO1015**  
EDGE OFF Noga Burr. Disposable tool with S10 Blade, Handy Pocket Clip in Blister Packaging.



**YT2000**  
New and unique YT Handle Hollow ground HSS D75 triangular adjustable scraper  
Double ended triangular adjustable scraper

**EB7000**  
EZ Burr Pro Set  
Comes with EB1000, EB2000, EB3000 & EB4000

**NG1503 NG1505**  
16 x NG1003 or NG1005 in a cardboard counter display

**Noga RB1500**  
20 RB1000 Rapid Burrs  
Aluminium handle with replaceable S10 blade

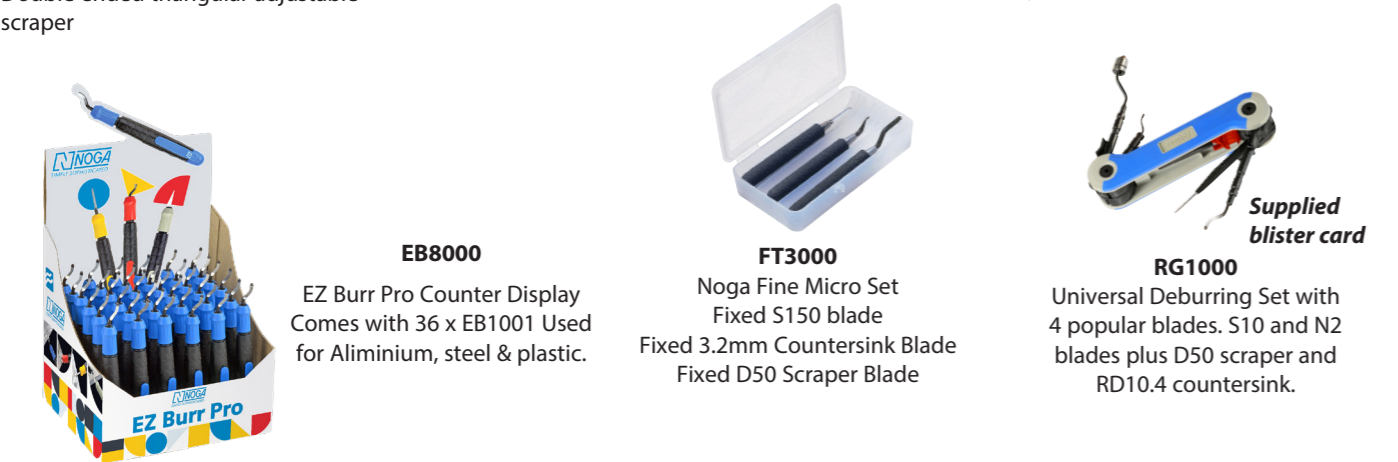

**EB8000**  
EZ Burr Pro Counter Display Comes with 36 x EB1001 Used for Aluminium, steel & plastic.

**FT3000**  
Noga Fine Micro Set  
Fixed S150 blade  
Fixed 3.2mm Countersink Blade  
Fixed D50 Scraper Blade

**RG1000**  
Universal Deburring Set with 4 popular blades. S10 and N2 blades plus D50 scraper and RD10.4 countersink.  
*Supplied blister card*

**SETS, KITS & MERCHANDISERS**



**UNIKIT STANDARD UK1000**  
Kit includes:  
Scraper T120, UNI-Handle  
SN Holder, C Holder + C20  
N1, N2, S101, S30, S20, S10



**NOGA BOX NX1000**  
Kit includes:  
Keyway Burr, Double Burr  
2 pcs Edge Off, D-Key,  
UNI-Handle + SN Holder  
C Holder + C20, C12  
D Holder + D50,  
D Holder + D66,  
L Holder + L1, N1, N2, S10,  
S101, S20, Scraper T120

**NOGA SP3500 Kit** Stainless steel deburring kit - contains:  
DB1000 equipped with M42 hardened blades  
NogaGrip Handle with S blade holder plus S100 cobalt and S20 carbide blades  
Adjustable scraper with D55 carbide blade



**PLATINUM BOX NG9500**  
Kit includes :  
Double Burr  
NogaGrip 1 handle  
NogaGrip 3 handle  
N Holder, S Holder  
Teddy Burr handle  
C Holder + C20  
D Holder + D50  
D Holder + D66  
K Holder + N80K  
T Holder + T70  
18mm external RotoDrive blade  
10.4mm countersink RotoDrive  
N1, N2, S10, S20,  
S30, & S150 blades  
Hex key 1.5mm

**Bronze UniKit NG9200**  
Kit includes :  
NogaGrip 3 handle  
N Holder  
S Holder  
C Holder + C20  
D Holder + D50  
N1, N2, S10, S20,  
S30, & S150 blades



**COUNTERSINK POWER TOOL SET CS7000**  
3 sizes Internal countersinks 12mm, 20mm and 30mm.  
- One size External countersink Range ø8-28mm  
- 2 Pcs. NOGA unique 1/4" adaptors allow you to use all standard power tools.



**SP7700**  
Kit includes 7 popular deburring tools:  
NG3003  
NG3710  
NG3300  
NG3200  
NG3700  
NG3100  
SC8000

**DIAMOND NEEDLE FILE SETS**

The files are of Swiss made blanks electroplated with ultra high concentration of precisely graded diamond particles.  
5 Diamond Needle Files -  
All 140mm total length, 70mm coated length, with 3mm shank  
Equaling - 5.1 x 1.4mm  
Triangular - 3.9mm  
Square - 2.5mm  
Half Round - 5.4 x 1.9mm  
Round - 3.0mm

Also comes with NOGA T80 Double ended triangular scraper and D75 mini scraper

Part No YT3000

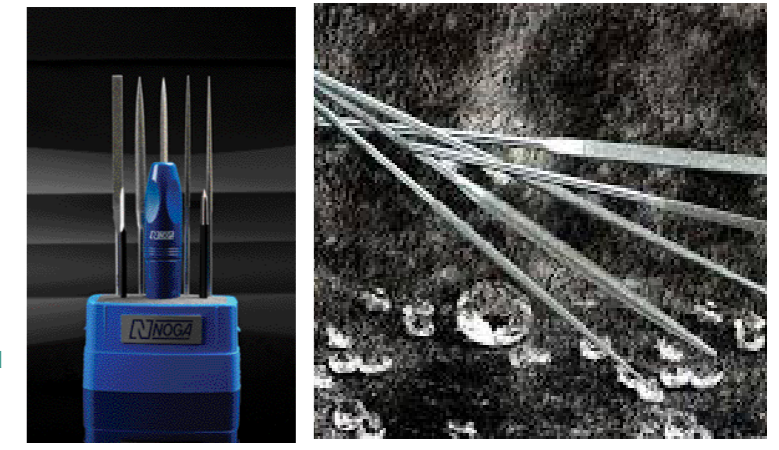

## COUNTERSINKS



Name Cat No.	Description	Blade holder & handles	Pack size
<b>C12 (F12)</b> BC1211	12mm 90 degree Countersink	all "C" series countersink blades are used with the CH3000 holder and NG3 Handle	1
<b>C20 (F20)</b> BC2011	20mm 90 degree Countersink		1
<b>C30 (F30)</b> BC3011	30mm 90 degree Countersink		1
<b>RD 3.2</b> BC3201 #	Cranked Csk 3.2mm	all "RD" cranked countersinks are used with either the NG1 handle or SN1000 holder with UH1000 handle	1
<b>RD 6.3</b> BC6301 #	Cranked Csk 6.3mm		1
<b>RD 8.3</b> BC8301 #	Cranked Csk 8.3mm		1
<b>RD 10.4</b> BC1041	Cranked Csk 10.4mm		1
<b>RD 16.5</b> BC1651	Cranked Csk 16.5mm		1
<b>RDE 18</b> EX2001	Cranked external Csk 4 - 18mm		1

## SCRAPER BLADES

<b>D50</b> BD5001	3.2x50mm triangular scraper.		1
<b>D66</b> BD6601	3.2x50mm 45 deg. Internal scraper		1
<b>D75</b> BD7501	75mm long. Fits Adj scraper handle	D75, D77 & T80 use adjustable scraper handle	1
<b>D77</b> BD7701	75mm long. Fits Adj scraper handle		1
<b>T 80</b> BT8001	Double medium scraper blade.		1
<b>T 120</b> BT1201	Double ended ground scraper.	UH1000 handle (no holder required)	1

## N BLADES

<b>N80</b> BN8001	Round blade used with double burr	N80 & N80M42 are used with DB1000	1
<b>N80M42</b> BN8043	N80 heat treated for stainless steel		1
<b>N70K</b> BN7001	For small keyways. 1.2 - 8mm		1
<b>N80K</b> BN8101	Std blade for the keyway tool.2.4-11mm	N70K, N80K, N80KM42, & N90K are used with KH1000 holder & UH1000 handle	1
<b>N80KM42</b> BN8143	N80K heat treated for stainless steel.		1
<b>N90K</b> BN9001	For larger keyways. 3 - 15mm.		1

## L & R BLADES

<b>L1</b> BL1001	Used with Leader for steel & aluminium	LH1000 holder with UH1000 handle	1
<b>R1</b> BR1001	For cross holes 3 - 5.5mm	Used with RC1000	1
<b>R2</b> BR2001	For cross holes 5 - 9mm	Used with RC2000	1
<b>R3</b> BR3001	For cross holes 10 - 22mm	Used with RC2200	1

## SWIVEL BLADES



Name Cat No.	Description	Blade holder & handles	Pack size
<b>N10</b> BN1310	Light duty for steel, aluminium and plastic	All "B" series & "N" series blades can be used with the following :	10
<b>N10-Plastic</b> BN1410	Specially ground for deburring plastics		10
<b>N1</b> BN1010	Light duty for steel, aluminium and plastic	SN1000 holder with UH1000 handle or N holder EL01033 with NG-3 handle or TB1000 (no extra holder required) or NG-2 Handle	10
<b>N1LH</b> BN1026	N1 for left handed user.		10
<b>N1 Tin</b> BN1012	Tin coated N1 for long life.		10
<b>N1 C</b> BN1015	Solid carbide N1 for hardened steel and special plastics.		10
<b>N2 (B20)</b> BN2010	Light duty for brass & cast iron		10
<b>N2 C</b> BN2015	Solid carbide N2 for ceramic and glass		10
<b>N3 (B30)</b> BN3010	Removes internal and external burrs simultaneously from holes drilled into tubing and sheet metal.	<b>The shank diameter on all "N" or "B" blades is 2.6mm</b>	10
<b>N6 (B60)</b> BN6001	For cross holes in difficult to reach places		1
<b>S10 (E100)</b> BS1010	Heavy duty for steel, aluminium and plastic	All "S" or "E" series blades can be used with the following :	10
<b>S10 LH</b> BS1011	S10 For left handed users		10
<b>S10 Tin</b> BS1012	Tin coated S10 for long life.		10
<b>S10 C</b> BS1016 #	Solid carbide tipped S10 for hardened steel & special plastics	SN1000 holder with UH1000 handle or S holder EL02003 with NG-3 handle or NG1 (no extra holder required) or RB1000 (no extra holder required)	1
<b>S100</b> BS1018	Combination blade best for plastics & hard materials.		10
<b>S101 (E110)</b> BK1010	H/D shank with fine cutting edge for steel, aluminium and plastic.		10
<b>S101 LH</b> BK1011	S101 for left handed users		10
<b>S101 Tin</b> BK1012	Tin coated S101 for long life		10
<b>S150</b> BK3010	H/D shank, for holes as small as 1.5mm diameter		10
<b>S20 (E200)</b> BS2010	Heavy duty for brass and cast iron		10
<b>S20 C</b> BS2015 #	Solid carbide tipped S20 for hardened materials	<b>The shank diameter on all "S" or "E" blades is 3.2mm</b>	1
<b>S202</b> BK2010	H/D shank with fine cutting edge for brass & cast iron		10
<b>S30 (E300)</b> BS3010	H/D removes internal & external burrs simultaneously from holes drilled into tubing & sheet metal		10
<b>S35 (E350)</b> BS3510	Heavy duty for straight edges		10
<b>S60 (E600)</b> BS6001	Heavy duty for cross holes in difficult to reach places		1
<b>TC</b> BC1001	Patented for internal thread cleaning & deburring from 9mm		1
<b>OR</b> BO1001	Patented HSS for "O" Ring grooves up to 3mm		1

Blades marked with # are non stock and may require minimum order quantities as special buy-ins



**SPIDER BURR**  
Self Adjusting Chamfering Tool



Unique mechanism enables quick outer edge burr removal.

Extremely fast chamfering on external tubes Ideal for the outside diameter of plastic pipes.  
Easy set up - the diameter of the Spider Burr automatically and quickly adjusts to the required outer circumference of the pipe.

Works on different plastic pipes and tubes such as UPVC, PVC, PP, PE, CPVC, ABS etc.  
Working range: 75 - 110 mm (2½" - 4"), 110 - 160 mm (4" - 6").  
Works best with standard electric/cordless drills - 14V and up.

For best performance run the drill at a low RPM.  
Use the drill position setting.  
Same blade is used for both models and is replaceable.

Part No	Range
PC2000	75-110mm
PC3000	110-160mm
PC1100	Replacement Blade

**INNER / OUTER REAMER**

**Fast Chamfering up to 75mm on Plastic**

Works on different plastic pipes and tubes such as UPVC, PVC, PP, PE, CPVC, ABS etc.

Working range: 25 - 75 mm (3/4" - 2 1/2").

Works best with standard electric/cordless drills - 14V and up. *For best performance run the drill at a low RPM.*

*Use the drill position setting.*

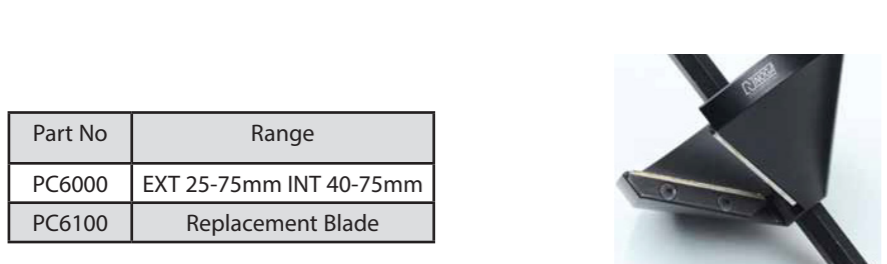

Part No	Range
PC6000	EXT 25-75mm INT 40-75mm
PC6100	Replacement Blade

**CHIP HOOKS**



NogaGrip handle, hand guard.

For removing :  
chips and cleaning chip  
trays on machines.

420mm overall length  
**SP2500**  
595mm overall length  
**SP2550**

**CUTTING FLUID APPLICATORS**

Strong Magnetic base, Separate On/Off air and fluid controls, Stainless steel armoured siphon hose and air hose, Nozzle connected via Loc-Line Flexible Hose, The spray unit comes in three standard lengths: 264, 334, 479 mm (special lengths available upon request).



**NOGA Minicool MC1700**

NOGA Minicool is using the VENTURI principle to spray an air + liquid mixture. The Minicool enables the user to easily control both the air flow rate and liquid rate.

- Strong magnetic base.
- Separate on/off air and fluid control.
- Stainless steel armoured syphon hose and air hose.
- Simple, inexpensive, rugged.
- Nozzle connected via Loc-Line® flexible hose.
- Single spray unit.

No. of spray units:	1
Spray unit length:	264mm
Air line length:	1m
Suction line length:	1m



**NOGA Minicool MC3000**

Identical to the MC1700 above, this Noga Minicool system has 2 spray units rather than 1.



Part No	Descriptions
MC1400	14 Loc-line segments (permanent magnet)
MC1700	14 Loc-line segments (ON/OFF magnet)
MC1900	19 Loc-line segment (permanent magnet)
MC2900	29 Loc-line segments (permanent magnet)
MC3000	2 x14 Loc-line segments (ON/OFF magnet)

Part No	Descriptions
MC1601	32 kg/f with on/off switch flexible hose w/ a tap has additional outlet.



**NOGA COOL ARM**  
**FIXED & VARI HP COOL ARMS**

The Fixed HP Cool Arm and Vari HP Cool Arm can be fitted with three different sizes of nozzles which will deliver fluids or cooling liquids at high pressure, up to 1000 PSI, allowing a higher level of machining. The arms are easy and fast to set in position.

Part No	Descriptions
CA2000	Fixed HP Cool Arm. Single arm with 2 end ball joints so the nozzles can move on wide curve for positioning.
CA3000	Vari HP Cool Arm. Long Articulated Arms provide full axis rotation. Sturdy tightening fixtures for total stability.



# LOC-LINE<sup>®</sup>

## IDENTIFYING LOC-LINE SYSTEMS

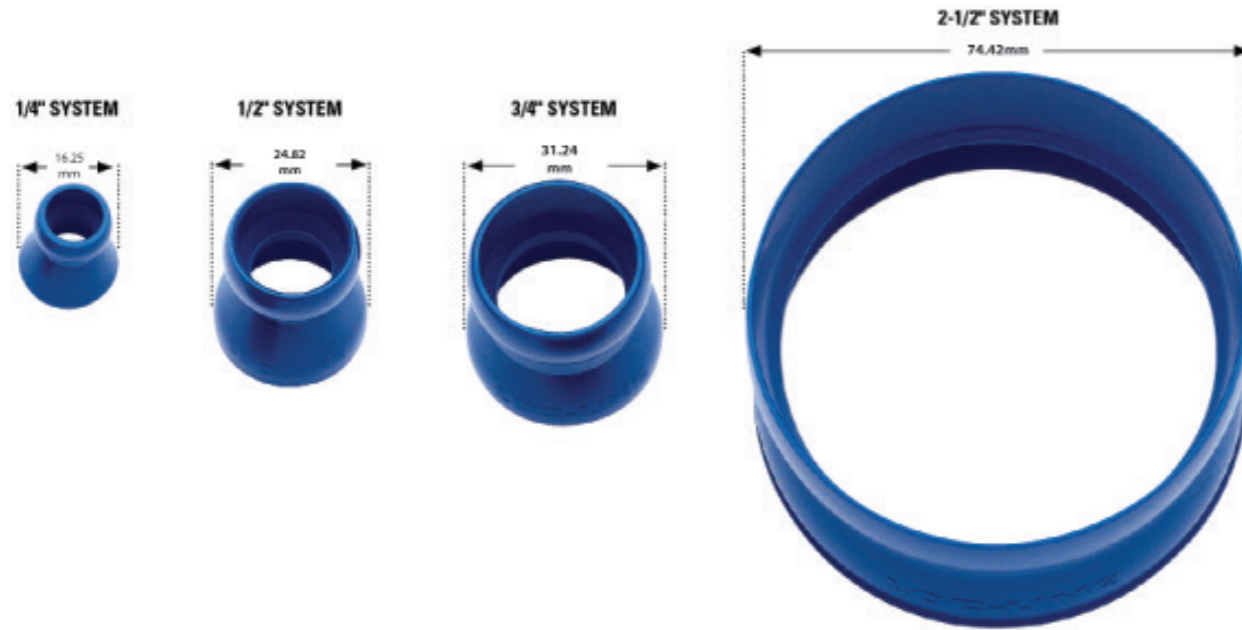

## MEASURING LOC-LINE

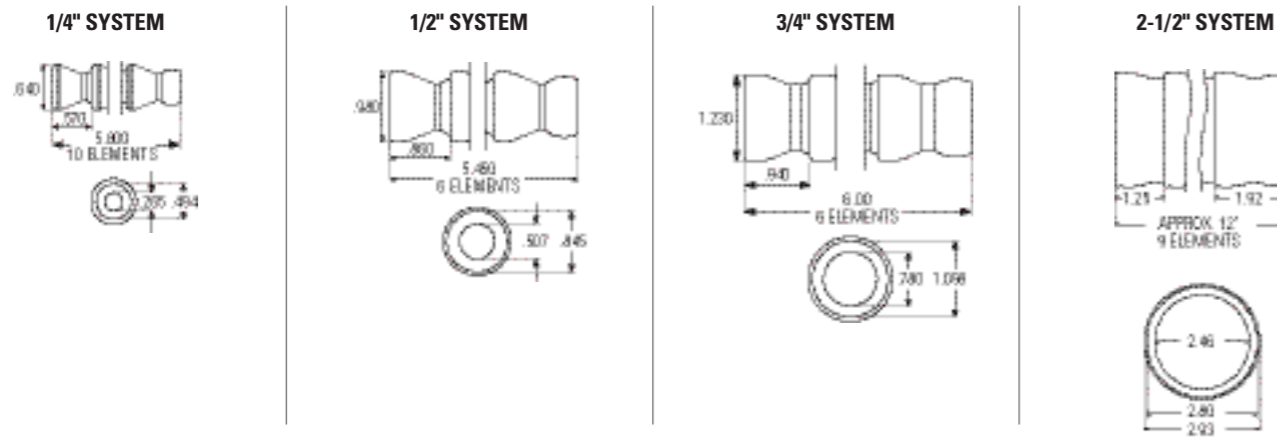

## MINIMUM HOSE BENDING DIAMETER

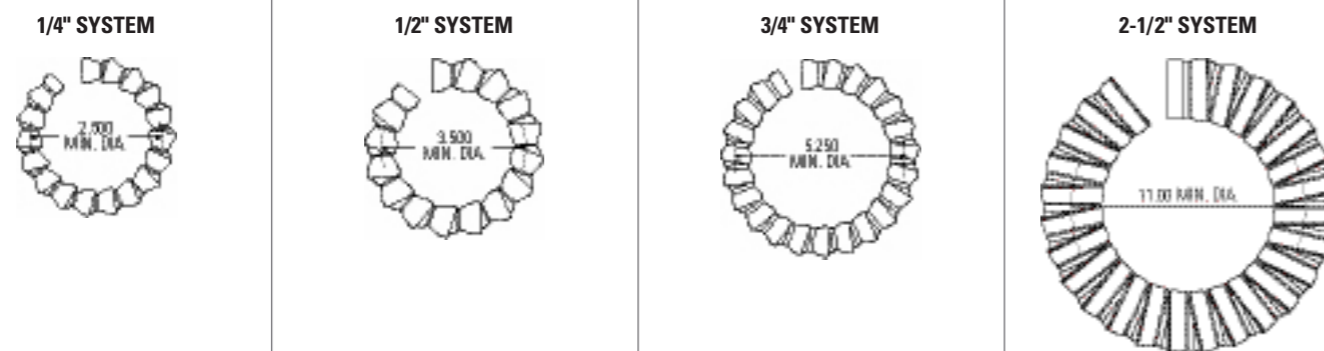

## LINE PRESSURE AND FLOW RATES

1/4" SYSTEM		
	LINE PRESSURE	FLOW RATE
Standard	50 PSI	250 gal/hr
w/ clamps	up to 110 PSI*	

\*Assumes use of element clamps on all joints and fully tightened.

Please note that all applications have variables and conditions that will affect the maximum hose pressures. Testing is always recommended whenever possible.

1/2" SYSTEM		
	LINE PRESSURE	FLOW RATE
Standard	30 PSI	478 gal/hr
w/ clamps	up to 75 PSI*	

\*Assumes use of element clamps on all joints and fully tightened.

## MATERIAL SPECIFICATIONS

### COMMON COMPATIBILITY WITH LOC-LINE ACETAL PRODUCTS

■ BLUE ■ ORANGE ■ BLACK ■ GREY □ WHITE

Yes	Acetone
No	Acids
Yes	Alcohol, Ethyl
No	Ammonium Hydroxide, Strong
No	Bases, Strong
Yes	Commercial Dish Detergents
Yes	Gasoline
Yes	Greases
No	Hypochlorite Ion Solutions
Yes	Lacquer Solvents
Yes	Oils
Yes	Sodium Hydroxide
No	Sodium Hypochlorite

### ACETAL TEMPERATURE DATA

■ BLUE ■ ORANGE ■ BLACK ■ GREY □ WHITE

Melting point: 329° F  
Maximum operating temperature: 170° F

### TEMPERATURE DATA - HPT NOZZLE

Maximum operating temperature: 115° F

### ACETAL ANTI-STATIC ELECTRICAL PROPERTIES

■ BLACK (2 1/2" System)  
Surface Resistivity: 1.000E3 Ohm  
Volume Resistivity: <6.000E2 Ohm-cm

### COMMON COMPATIBILITY WITH LOC-LINE POLYESTER PRODUCTS

■ YELLOW ACID RESISTANT

No	Acetone
Yes	Acids, (Less than 150° F)
No	Acids, (Greater than 150° F)
Yes	Alcohols
Yes	Aromatic Solvents
No	Chlorinated Hydrocarbon
No	Bases, Strong
No	Ethyl Acetate
Yes	Gasoline
Yes	Greases
Yes	Hydrocarbons
Yes	Oils
Yes	Salt Solutions

### TEMPERATURE DATA - POLYESTER

■ YELLOW ACID RESISTANT

Melting point: 475° F  
Maximum operating temperature: 170° F



KITS

1/4" HOSE KIT

- 40413**  
 (2) 5/4" Long Segments  
 (1) 1/4" Round Nozzle  
 (1) 1/8" Round Nozzle  
 (1) 1/16" Round Nozzle  
 (1) 1/4" NPT Connector  
 (1) 1/8" NPT Connector

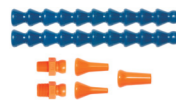

• Assembled Length = 13"

1/4" TAP HOSE NOZZLE KIT

- 40499**  
 (1) 13" Length with Fitting  
 (2) 5/4" Long Segments  
 (1) 1/8" Round Nozzle  
 (1) 1/4" NPT Male Valve

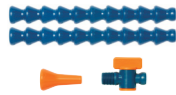

• Assembled Length = 13"

1/4" FLARED TUBING REPLACEMENT PACK

- 40452**  
 (8) 5/4" Long Segments  
 (1) 1" Flare Nozzle  
 (4) 3/8" Flare Nut Adapters  
 (4) 1/8" Round Nozzles  
 (4) 1/4" Round Nozzles

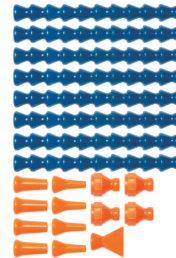

1/2" LATHE ADAPTER KIT

- 40475**  
 (4) 1/2" Short Adapters  
 (4) 1/2" x 2" Adapters  
 (2) Flat 5-Hole Nozzles  
 (2) Flat Slot 60 Nozzles  
 (2) 1/8" 90° Nozzles  
 (2) 1/4" 90° Nozzles  
 (2) 1/8" Round Nozzles  
 (2) 1/4" Round Nozzles  
 (2) Straight Flow Nozzles  
 (4) Element Clamps w/ screws

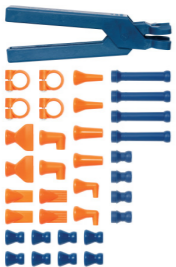

- (8) Elements  
 (1) 1/4" Assembly Pliers

15 MM LATHE ADAPTER KIT

- 40476**  
 (4) 15 mm Short Adapters  
 (4) 15 mm x 2" Adapters  
 (2) Flat 5 Hole Nozzles  
 (2) Flat Slot 60 Nozzles  
 (2) 1/8" 90° Nozzles  
 (2) 1/4" 90° Nozzles  
 (2) 1/8" Round Nozzles  
 (2) 1/4" Round Nozzles  
 (2) Straight Flow Nozzles  
 (4) Element Clamps w/ screws  
 (8) Elements  
 (1) 1/4" Assembly Pliers



1/4" EXTENDED ELBOW KIT

- 40472**  
 (4) Extended Elbows  
 (4) Element Clamps w/ screws  
 (1) 1/8" NPT Connector  
 (1) 1/4" NPT Connector  
 (1) 1/16" Round Nozzle  
 (1) 1/8" Round Nozzle  
 (1) 1/4" Round Nozzle



1/4" MIXED ELEMENT KIT

- 40473**  
 (2) Extended Elbows  
 (2) Extended Elements  
 (4) Element Clamps w/ screws  
 (1) 1/8" NPT Connector  
 (1) 1/4" NPT Connector  
 (1) 1/16" Round Nozzle  
 (1) 1/8" Round Nozzle  
 (1) 1/4" Round Nozzle



1/4" EXTENDED ELBOWS WITH CLAMPS

- 40474**  
 (4) Extended Elbows  
 (4) Element Clamps w/ screws



1/4" EXTENDED ELEMENT KIT WITH CLAMPS

- 41475**  
 (4) 1/4" Extended Elements  
 (4) 1/4" Element Clamps w/ screws

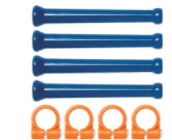

1/4" CIRCLE FLOW NOZZLE KIT

- 41479**  
 Assembled with:  
 (15) 1/4" Side Flow Nozzles  
 (1) 1/4" End Cap



Overall Length = 17.56"

1/4" PROSTREAM® NOZZLE KIT

- 42400**  
 (1) 5/4" Long Segments  
 (1) ProStream® Nozzle 0.160"ø x 1.25"L  
 (8) 1/4" Element Clamps w/ screws  
 (1) 1/4" NPT Connector  
 (1) 1/8" NPT Connector

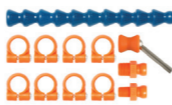

CONNECTORS

1/8" NPT CONNECTOR

- 41405**  
 (4) NPT Connectors  
**49425**  
 (50) NPT Connectors



1/8" BSPT\* CONNECTOR

- 41417**  
 (4) BSPT Connectors  
**49437**  
 (50) BSPT Connectors



\*British Standard Pipe Thread

1/4" NPT CONNECTOR

- 41406**  
 (4) NPT Connectors  
**49426**  
 (50) NPT Connectors



1/4" BSPT\* CONNECTOR

- 41418**  
 (4) BSPT Connectors  
**49438**  
 (50) BSPT Connectors



\*British Standard Pipe Thread

3/8" SAE FLARE NUT ADAPTER

- 41412**  
 (4) Flare Nut Adapters  
**49432**  
 (20) Flare Nut Adapters



5/8 - 18 Thread

1/4" SAE FLARE NUT ADAPTER

- 41414**  
 (4) Flare Nut Adapters  
**49434**  
 (20) Flare Nut Adapters



7/16 - 20 Thread

15 MM "SHORT" LATHE ADAPTER

- 41492**  
 (4) Lathe Adapters  
**49458**  
 (20) Lathe Adapters



15 MM X 2" LATHE ADAPTER

- 41493**  
 (4) Lathe Adapters  
**49459**  
 (20) Lathe Adapters



1/2" "SHORT" LATHE ADAPTER

- 41494**  
 (4) Lathe Adapters  
**49460**  
 (20) Lathe Adapters



1/2" x 2" LATHE ADAPTER

- 41495**  
 (4) Lathe Adapters  
**49461**  
 (20) Lathe Adapters



NOZZLES

1/4" NOZZLE-RAMA PACK

- 41490**  
 (20) Includes 1 nozzle from each of these packages:  
 41402, 41403, 41404, 41407, 41460, 41461, 41462, 41463, 41470, 41471, 41472, 41473, 41481, 41482, 41483, 41484, 41485, 41486, 41488, 41489



1/4" 90° NOZZLE KIT

- 41474**  
 (1) 1/16" 90° Nozzle  
 (1) 1/8" 90° Nozzle  
 (1) 1/4" 90° Nozzle  
 (1) 1/4" 90° Spray Bar Nozz



1/4" FLAT NOZZLE ASSORTMENT PACK

- 41487**  
 (1) Flat Slot 40 Nozzle  
 (1) Flat Slot 60 Nozzle  
 (1) Flat 5 Hole Nozzle  
 (1) Flat 7 Hole Nozzle



1/16" ROUND NOZZLE

- 41402**  
 (4) Round Nozzles  
**49422**  
 (50) Round Nozzles



1/8" ROUND NOZZLE

- 41403**  
 (4) Round Nozzles  
**49423**  
 (50) Round Nozzles



1/4" ROUND NOZZLE

- 41404**  
 (4) Round Nozzles  
**49424**  
 (50) Round Nozzles



1" FLARE NOZZLE

- 41407**  
 (2) Flare Nozzles  
**49427**  
 (20) Flare Nozzles



1" STRAIGHT FLOW NOZZLE

- 41489**  
 (2) Straight Flow Nozzles  
**49456**  
 (20) Straight Flow Nozzles



1/16" 90° NOZZLE

- 41470**  
 (4) 90° Nozzles  
**49439**  
 (20) 90° Nozzles



1/8" 90° NOZZLE

- 41471**  
 (4) 90° Nozzles  
**49440**  
 (20) 90° Nozzles



1/4" 90° NOZZLE

- 41472**  
 (4) 90° Nozzles  
**49441**  
 (20) 90° Nozzles



1/4" 90° SPRAY BAR NOZZLE

- 41473**  
 (2) 90° Spray Bar Nozzles  
**49442**  
 (20) 90° Spray Bar Nozzles



HOSES

1/4" HOSE

- 41401**  
 (2) 5/4" Long Segments\*  
**49419**  
 (1) 5 ft Coil  
**49420**  
 (55) Segments\*, Bulk 25-ft  
**49421**  
 (1) 50 ft Coil



\*1 Segment = 10 Element

1/4" EXTENDED ELEMENT

- 41476**  
 (4) Extended Elements  
**49445**  
 (20) Extended Elements



1/4" EXTENDED ELBOW

- 41491**  
 (4) Extended Elbows  
**49457**  
 (20) Extended Elbows



HOW TO ORDER BLACK, GRAY OR WHITE LOC-LINE:  
 (Add suffix to part number when ordering, ie: 49421-BLK)  
 -BLK Part can be ordered in Black, add suffix -BLK  
 -G Part can be ordered in Gray, add suffix -G  
 -W Part can be ordered in White, add suffix -W

NOZZLES (continued)

3/32" 45° NOZZLE

- 41460 (4) 3/32" 45° Nozzles
- 49470 (20) 3/32" 45° Nozzles



1/8" 45° NOZZLE

- 41461 (4) 1/8" 45° Nozzles
- 49471 (20) 1/8" 45° Nozzles



3/16" 45° NOZZLE

- 41462 (4) 3/16" 45° Nozzles
- 49472 (20) 3/16" 45° Nozzles



1/4" 45° NOZZLE

- 41463 (4) 1/4" 45° Nozzles
- 49473 (20) 1/4" 45° Nozzles



1/4" FLAT SLOT 40 NOZZLE

- 41483 (4) Flat Slot Nozzles
  - 49451 (20) Flat Slot Nozzles
- 0.040" Slot height



1/4" FLAT SLOT 60 NOZZLE

- 41484 (4) Flat Slot Nozzles
  - 49452 (20) Flat Slot Nozzles
- 0.060" Slot height



1/4" FLAT 5-HOLE NOZZLE

- 41485 (4) Flat 5-Hole Nozzles
  - 49453 (20) Flat 5-Hole Nozzles
- 0.060" Hole diameter



1/4" FLAT 7-HOLE NOZZLE

- 41486 (4) Flat 7-Hole Nozzles
  - 49454 (20) Flat 7-Hole Nozzles
- 0.040" Hole diameter



1/4" SIDE FLOW NOZZLE

- 41478 (4) Side Flow Nozzles
- 49443 (20) Side Flow Nozzles



1/4" SWIVEL NOZZLE 40

- 41481 (2) Swivel Nozzles
  - 49449 (20) Swivel Nozzle
- 0.040" Hole diameter



1/4" SWIVEL NOZZLE 60

- 41482 (2) Swivel Nozzles
  - 49450 (20) Swivel Nozzles
- 0.060" Hole diameter



2 1/2" SWIVEL NOZZLE 75

- 41488 (2) Swivel Nozzles
  - 49455 (20) Swivel Nozzles
- 0.075" Hole diameter



PROSTREAM® NOZZLES

.062"Øx.50"L PROSTREAM® NOZZLE

- 41420 (2) ProStream Nozzles
- 49480 (10) ProStream Nozzles



.062"Øx1.25"L PROSTREAM® NOZZLE

- 41424 (2) ProStream Nozzles
- 49484 (10) ProStream Nozzles



.086"Øx.50"L PROSTREAM® NOZZLE

- 41421 (2) ProStream Nozzles
- 49481 (10) ProStream Nozzles



.086"Øx1.25"L PROSTREAM® NOZZLE

- 41425 (2) ProStream Nozzles
- 49485 (10) ProStream Nozzles



.117"Øx.50"L PROSTREAM® NOZZLE

- 41422 (2) ProStream Nozzles
- 49482 (10) ProStream Nozzles



.117"Øx1.25"L PROSTREAM® NOZZLE

- 41426 (2) ProStream Nozzles
- 49486 (10) ProStream Nozzles



.160"Øx.50"L PROSTREAM® NOZZLE

- 41423 (2) ProStream Nozzles
- 49483 (10) ProStream Nozzles



.160"Øx1.25"L PROSTREAM® NOZZLE

- 41427 (2) ProStream Nozzles
- 49487 (10) ProStream Nozzles



BALL ADAPTERS

10 MMØ X 1/4" LOC-LINE® BALL ADAPTER

- 41740 (2) Brass Ball Adapters
- 49740 (10) Brass Ball Adapters



12 MMØ X 1/4" LOC-LINE® BALL ADAPTER

- 41741 (2) Brass Ball Adapters
- 49741 (10) Brass Ball Adapters



14 MMØ X 1/4" LOC-LINE® BALL ADAPTER

- 41743 (2) Brass Ball Adapters
- 49743 (10) Brass Ball Adapters



15 MMØ X 1/4" LOC-LINE® BALL ADAPTER

- 41742 (2) Brass Ball Adapters
- 49742 (10) Brass Ball Adapters



12 MMØ X 1/8" NPT BRASS BALL ADAPTER

- 41498 (2) Brass Ball Adapters
- 49493 (10) Brass Ball Adapters



14 MMØ X 1/8" NPT BRASS BALL ADAPTER

- 41497 (2) Brass Ball Adapters
- 49495 (10) Brass Ball Adapters



15 MMØ X 1/8" NPT BRASS BALL ADAPTER

- 41496 (2) Brass Ball Adapters
- 49496 (10) Brass Ball Adapters



BRASS ADAPTERS

VALVES

1/4" MALE NPT VALVE

- 21192 (2) Male NPT Valves
- 29452 (10) Male NPT Valves

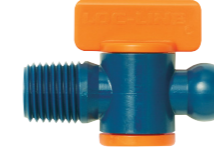

1/4" IN-LINE VALVE

- 21194 (2) In-Line Valves
- 29454 (10) In-Line Valves



1/4" FEMALE NPT VALVE

- 21193 (2) Female NPT Valves
- 29453 (10) Female NPT Valves

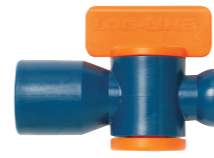

1/4" IN-LINE CHECK VALVE

- 21191 (2) Check Valves
- 29451 (10) Check Valves



ACCESSORIES

1/4" ELEMENT CLAMP

- 41477 (4) Element Clamps w/ screws
- 49446 (20) Element Clamps w/ screws



1/4" SOCKET X 1/8" FNPT

- 41411 (4) 1/4" Socket X 1/8" FNPT
- 49431 (20) 1/4" Socket X 1/8" FNPT



1/4" END CAP

- 41480 (4) End Caps
- 49447 (20) End Caps



1/4" Y

- 41408 (2) Y's
- 49428 (20) Y's



1/4" ELBOW

- 41415 (2) Elbows
- 49435 (20) Elbows



1/4" BRASS HOSE BARB

- 40488 (4) Brass Hose Barbs
- 49488 (10) Brass Hose Barbs



1/4" DOUBLE SOCKET

- 41409 (4) Double Sockets
- 49429 (20) Double Sockets



1/4" T

- 41416 (2) T's
- 49436 (20) T's



1/4" HOSE ASSEMBLY PLIERS

- 78001 (1) 1/4" Pliers
- 78003 (1) 1/4" Pliers
- 78003 (1) 1/2" Pliers



MANIFOLDS

MAGNETIC BASE MANIFOLD

- 40400 (1) Magnetic Base Manifold
  - (3) 1/4" Plugs
  - (1) 1/4" Barb
- 25 lb / 11.3kg Holding Force



MAGNETIC BASE MANIFOLD KIT

- 40463 (2) 5/8" Long Segments
- (1) 1/4" MNPT Valve
- (1) 1" Flare Nozzle
- (1) 1/4" Round Nozzle
- (1) 1/8" Round Nozzle
- (1) 1/16" Round Nozzle
- (1) Mag. Base Manifold
- (3) 1/4" Plugs
- (1) 1/4" Barb

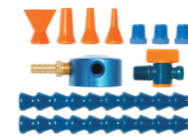

MAGNETIC BASE MANIFOLD SUPER KIT

- 40480 (8) 5/8" Long Segments
- (5) 1/4" MNPT Valves
- (2) 1" Flare Nozzles
- (2) 1/4" Round Nozzles
- (2) 1/8" Round Nozzles
- (2) 1/16" Round Nozzles
- (1) Mag. Base Manifold
- (3) 1/4" Plugs
- (1) 1/4" Barb

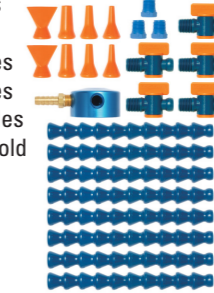

1/4" MODULAR MANIFOLD

- 21199 (3) 1/4" T's
- (1) 1/4" Elbow
- (1) 1/4" Manifold Bracket
- (3) Mounting Screws

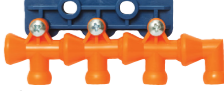

1/4" TOTAL FLOW CONTROL MANIFOLD

- 21198 (1) 1/4" Modular Manifold
- (5) 1/4" In-Line Valves



1/4" MODULAR MANIFOLD BRACKET

- 21195 (2) Brackets



KITS

1/2" HOSE KIT

- 50813**  
 (2) 5 1/2" Long Segments  
 (1) 1/4" Round Nozzle  
 (1) 3/8" Round Nozzle  
 (1) 1/2" Round Nozzle  
 (1) 3/8" NPT Connector  
 (1) 1/2" NPT Connector  
 • Assembled Length = 13"

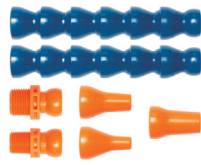

1/2" MIXED ELEMENT KIT

- 50873**  
 (1) 3/8" NPT Connector  
 (1) 1/2" NPT Connector  
 (1) 1/4" Round Nozzle  
 (1) 3/8" Round Nozzle  
 (1) 1/2" Round Nozzle  
 (2) Extended Elbows  
 (2) Extended Elements  
 (4) Element Clamps w/ screws

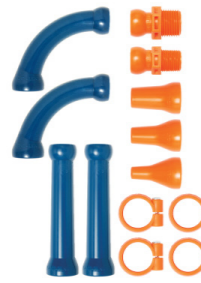

1/2" SYSTEM HOSE & TAP KIT

- 50899**  
 (2) 5 1/2" Long Segments  
 (1) 3/8" Round Nozzle  
 (1) 1/2" NPT Male Valve  
 • Assembled Length = 13"

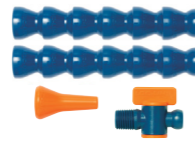

1/2" EXTENDED ELBOWS WITH CLAMPS

- 50874**  
 (4) Extended Elbows  
 (4) Element Clamps w/ screws



1/2" EXTENDED ELEMENT KIT W/ CLAMPS

- 51835**  
 (4) 1/2" Extended Elements  
 (4) Element Clamps w/ screws



1/2" EXTENDED ELBOW KIT

- 50872**  
 (1) 3/8" NPT Connector  
 (1) 1/2" NPT Connector  
 (1) 1/4" Round Nozzle  
 (1) 3/8" Round Nozzle  
 (1) 1/2" Round Nozzle  
 (4) Extended Elbows  
 (4) Element Clamps w/ screws



1/2" CIRCLE FLOW NOZZLE KIT

- 51837**  
 Assembled with  
 (15) 1/2" Side Flow Nozzles  
 (1) 1/2" End Cap  
 • Overall Length = 24.375"



HOSES

1/2" HOSE

- 51801**  
 (2) 5 1/2" Long Segments  
**59860**  
 (59) Segments, Bulk 25 ft  
**59859**  
 (1) 5 ft Coil  
**59861**  
 (1) 50 ft Coil  
 • 1 Segment = 6 Elements



1/2" EXTENDED ELEMENT

- 51833**  
 (4) Extended Elements  
**59883**  
 (20) Extended Elements



1/2" EXTENDED ELBOW

- 51896**  
 (4) Extended Elbows  
**59899**  
 (20) Extended Elbows



CONNECTORS

3/8" NPT CONNECTOR

- 51804**  
 (4) NPT Connectors  
**59864**  
 (50) NPT Connectors



3/8" BSPT\* CONNECTOR

- 51826**  
 (4) BSPT Connectors  
**59876**  
 (50) BSPT Connectors  
 \* British Standard Pipe Thread



1/2" NPT CONNECTOR

- 51805**  
 (4) NPT Connectors  
**59865**  
 (50) NPT Connectors



1/2" BSPT\* CONNECTOR

- 51827**  
 (4) BSPT Connectors  
**59877**  
 (50) BSPT Connectors  
 \* British Standard Pipe Thread



3/8" SAE FLARE NUT ADAPTER

- 51823**  
 (4) Flare Nut Adapters  
**59873**  
 (20) Flare Nut Adapters  
 5/8 - 18 Thread



**HOW TO ORDER BLACK, GRAY OR WHITE LOC-LINE:**  
 (Add suffix to part number when ordering, ie: 49421-BLK)  
 ■-BLK Part can be ordered in Black, add suffix -BLK  
 ■-G Part can be ordered in Gray, add suffix -G  
 ■-W Part can be ordered in White, add suffix -W

NOZZLES

1/2" NOZZLE-RAMA PACK

- 51849**  
 (16) Includes 1 nozzle from each of these packages:  
 51802, 51803, 51806, 51807, 51809, 51828, 51829, 51830, 51831, 51840, 51841, 51842, 51843, 51845, 51847, 51848

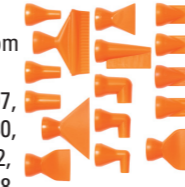

1/2" 90° NOZZLE KIT

- 51832**  
 (1) 1/4" 90° Nozzle  
 (1) 3/8" 90° Nozzle  
 (1) 1/2" 90° Nozzle  
 (1) 1/2" 90° Spray Bar Nozzle



1/2" FLAT NOZZLE ASSORTMENT

- 51844**  
 (1) Flat Slot 80 Nozzle  
 (1) Flat Slot 125 Nozzle  
 (1) Flat 5-Hole Nozzle  
 (1) Flat 7-Hole Nozzle

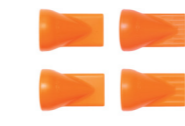

1/4" ROUND NOZZLE FOR 1/2"

- 51806**  
 (4) Round Nozzles  
**59866**  
 (50) Round Nozzles



3/8" ROUND NOZZLE

- 51802**  
 (4) Round Nozzles  
**59862**  
 (50) Round Nozzles



1/2" ROUND NOZZLE

- 51803**  
 (4) Round Nozzles  
**59863**  
 (50) Round Nozzles



1/4" 90° NOZZLE

- 51828**  
 (4) 90° Nozzles  
**59878**  
 (20) 90° Nozzles



3/8" 90° NOZZLE

- 51829**  
 (4) 90° Nozzles  
**59879**  
 (20) 90° Nozzles



1/2" 90° NOZZLE

- 51830**  
 (4) 90° Nozzles  
**59880**  
 (20) 90° Nozzles



1/2" 90° SPRAY BAR NOZZLE

- 51831**  
 (2) 90° Spray Bar Nozzles  
**59881**  
 (20) 90° Spray Bar Nozzles



1/4" FLARE NOZZLE

- 51807**  
 (2) Flare Nozzles  
**59867**  
 (20) Flare Nozzles



2 1/2" FLARE NOZZLE

- 51809**  
 (2) Flare Nozzles  
**59871**  
 (20) Flare Nozzles



1/2" SIDE FLOW NOZZLE

- 51836**  
 (4) Side Flow Nozzles  
**59889**  
 (20) Side Flow Nozzles



2 1/2" SWIVEL NOZZLE 75 FOR 1/2"

- 51845**  
 (2) Swivel Nozzles  
**59895**  
 (20) Swivel Nozzles  
 • .075" Hole diameter



1 1/4" STRAIGHT FLOW NOZZLE

- 51848**  
 (2) Straight Flow Nozzles  
**59898**  
 (20) Straight Flow Nozzles



1/2" FLAT SLOT 80 NOZZLE

- 51840**  
 (4) Flat Slot Nozzles  
**59890**  
 (20) Flat Slot Nozzles  
 • .080" Slot height



1/2" FLAT SLOT 125 NOZZLE

- 51841**  
 (4) Flat Slot Nozzles  
**59891**  
 (20) Flat Slot Nozzles  
 • .125" Slot height



1/2" FLAT 5-HOLE NOZZLE

- 51842**  
 (4) Flat 5-Hole Nozzles  
**59892**  
 (20) Flat 5-Hole Nozzles  
 • .125" Hole diameter



1/2" FLAT 7 HOLE NOZZLE

- 51843**  
 (4) Flat 7-Hole Nozzles  
**59893**  
 (20) Flat 7-Hole Nozzles  
 • .080" Hole diameter





1 1/4" STRAIGHT FLOW NOZZLE

- 51847**  
 (2) Straight Flow Nozzles  
**59897**  
 (20) Straight Flow Nozzles





## VALVES

### 1/2" MALE NPT VALVE

- 32092**  (2) Male NPT Valves  
**39852**   (10) Male NPT Valves



### 1/2" FEMALE NPT VALVE

- 32093**  (2) Female NPT Valves  
**39853**   (10) Female NPT Valves





### 1/2" IN-LINE VALVE

- 32094**  (2) In-Line Valves  
**39854**   (10) In-Line Valves





### 1/2" IN-LINE CHECK VALVE

- 32091**  (2) Check Valves  
**39851**   (10) Check Valves





## ACCESSORIES

### 1/2" ELEMENT CLAMP

- 51834**  (4) Element Clamps w/ screws  
**59884**   (20) Element Clamps w/ screws



### 1/2" END CAP

- 51838**  (4) End Caps  
**59885**   (20) End Caps





### 1/2" DOUBLE SOCKET

- 51811**  (4) Double Sockets  
**59872**   (20) Double Sockets



### 1/2" ELBOW

- 51824**  (2) Elbows  
**59874**   (20) Elbows





### 1/2" T

- 51825**  (2) T's  
**59875**   (20) T's



### 1/2" MAGNETIC BASE

- 51846**   (1) Magnetic Base  
 • 60 lb holding force





### 1/2" Y

- 51808**  (2) Y's  
**59868**   (20) Y's





### 1/2" TO 1/4" Y REDUCER

- 51822**  (2) Y Reducers  
**59870**   (20) Y Reducers





### 1/2" TO 1/4" REDUCER

- 51821**  (2) Reducers  
**59869**   (20) Reducers





### 1/2" FIXED MOUNT

- 51895**  (2) Fixed Mounts  
**59896**   (20) Fixed Mounts



• Mounts with 1/4" bolt, not included

### 1/2" HOSE ASSEMBLY PLIERS

- 78002**  (1) 1/2" pliers  
**78003**  (1) 1/4" pliers  
 (1) 1/2" pliers



## MANIFOLDS

### 1/2" MODULAR MANIFOLD

- 32099**  (3) 1/2" T's  
 (1) 1/2" Elbow  
 (1) 1/2" Manifold Bracket  
 (3) Mounting Screws

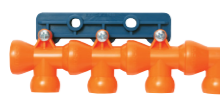

### 1/2" TOTAL FLOW CONTROL MANIFOLD

- 32098**  (1) 1/2" Modular Manifold  
 (5) 1/2" In-Line Valves

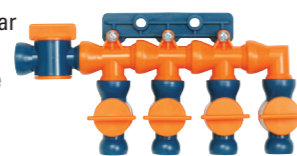

### 1/2" MODULAR MANIFOLD BRACKET

- 32095**  (2) Brackets



## 3/4-INCH SYSTEM

**LOC-LINE**

## KIT

### 3/4" HOSE KIT



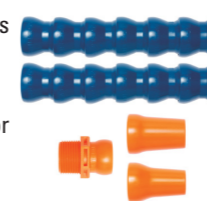



- 60513**  (2) 5 3/4" Long Segments  
 (1) 5/8" Round Nozzle  
 (1) 3/4" Round Nozzle  
 (1) 3/4" NPT Connector



• Assembled Length = 14"

## HOSES

### 3/4" HOSE



- 61501**  (2) 5 3/4" Long Segments  
**69539**   (1) 5 ft Coil  
**69540**   (54) Segments, Bulk 25 ft  
**69541**   (1) 50 ft Coil



• 1 Segment = 6 Elements



## CONNECTORS

### 3/4" NPT CONNECTOR

- 61505**  (4) NPT Connectors  
**69545**   (50) NPT Connectors



### 3/4" BSPT\* CONNECTOR



- 61509**  (4) BSPT Connectors  
**69549**   (50) BSPT Connectors



\* British Standard Pipe Thread



## NOZZLES

### 5/8" ROUND NOZZLE

- 61503**  (4) Round Nozzles  
**69543**   (50) Round Nozzles





### 3/4" ROUND NOZZLE

- 61502**  (4) Round Nozzles  
**69542**   (50) Round Nozzles





### 3" FLARE NOZZLE

- 61507**  (2) Flare Nozzles  
**69547**   (20) Flare Nozzles





## VALVES

### 3/4" MALE NPT VALVE

- 61516**  (2) NPT Valves  
**69556**   (10) NPT Valves



### 3/4" FEMALE NPT VALVE

- 61517**  (2) Female NPT Valves  
**69557**   (10) Female NPT Valves





### 3/4" IN-LINE VALVE

- 61518**  (2) In-Line Valves  
**69558**   (10) In-Line Valves





## ACCESSORIES

### 3/4" ELEMENT CLAMP

- 61535**  (4) Element Clamps w/ screws  
**69565**   (20) Element Clamps w/ screws





### 3/4" TO 1/2" Y REDUCER

- 61512**  (2) Y Reducers  
**69552**   (20) Y Reducers





### 3/4" Y

- 61511**  (2) Y's  
**69551**   (20) Y's





### 3/4" TO 1/2" REDUCER

- 61508**  (2) Reducers  
**69548**   (20) Reducers





### 3/4" ELBOW

- 61515**  (2) Elbows  
**69555**   (20) Elbows





### 3/4" DOUBLE SOCKET

- 61514**  (4) Double Sockets  
**69554**   (20) Double Sockets



### 3/4" FIXED MOUNT

- 60533**  (2) Fixed Mounts  
**69563**   (20) Fixed Mounts  
 • Mounts with 1/4" bolt, not included





### 3/4" HOSE ASSEMBLY PLIERS

- 78004**  (1) 3/4" Pliers



• 3/4" Assembly Pliers will not assemble the 3/4" Y Fitting, the 3/4" Fixed Mount or the 3/4" Valves.

**HOW TO ORDER BLACK, GRAY OR WHITE LOC-LINE:**  
 (Add suffix to part number when ordering, ie: 49421-BLK)  
 -BLK Part can be ordered in Black, add suffix -BLK  
 -G Part can be ordered in Gray, add suffix -G  
 -W Part can be ordered in White, add suffix -W

## QUICK-SET™ SHIELDS

LOC-LINE

### KIT

#### QUICK-SET SHIELD™ KIT

- 60525**  
(1) 6"x8" Shield Kit
- 60526**  
(1) 7½"x10" Shield Kit
- 60527**  
(1) 8½"x12" Shield Kit



- All Quick-Set Shield Kits include a 14" adjustable ¾" Loc-Line® arm, magnetic base and fitting for fixed mounting.

### ACCESSORIES

#### SHIELD MOUNTING ELBOW

- 60531** ■  
(2) Mounting Elbows
- 69561** ■ ■ ■  
(20) Mounting Elbows
- Washer and screw included



#### REPLACEMENT SHIELD

- 60528**  
(1) 6" x 8" Shield
- 60529**  
(1) 7½" x 10" Shield
- 60530**  
(1) 8½" x 12" Shield



#### ¾" MAGNETIC BASE

- 60532** ■ ■ ■  
(1) Magnetic Base
- 60 lb holding force



#### ¾" FIXED MOUNT

- 60533** ■  
(2) Fixed Mounts
- 69563** ■ ■ ■  
(20) Fixed Mounts



- Mounts with ¼" bolt, not included.

## MIRROR PRODUCTS

### KIT

#### INSPECTION MIRROR KIT

- 50501**  
(1) 2.125" x 3.5" Mirror
- (1) Mirror Mount Nozzle
- (1) Mirror Link
- (1) 1/2" x 11" Hose
- (1) 1/2" Magnetic Base



### ACCESSORIES

#### 1/2" MIRROR MOUNT

- 51503** ■  
(2) Mirror Mounts



#### REPLACEMENT MIRROR

- 51501**  
(1) 2.125" x 3.5" Mirror



#### MIRROR LINK

- 51502**  
(2) Mirror Links



**HOW TO ORDER BLACK, GRAY OR WHITE LOC-LINE:**  
(Add suffix to part number when ordering, ie: 49421-BLK)  
■-BLK Part can be ordered in Black, add suffix -BLK  
■-G Part can be ordered in Gray, add suffix -G  
□-W Part can be ordered in White, add suffix -W

## 2 1/2-INCH SYSTEM

### KIT

#### VACUUM HOSE KIT FOR 2½" SHOP VACUUM

- 80813**  
(2) 12" Vacuum Hose
- (1) Rectangular Nozzle
- (1) Tapered Nozzle
- (1) Shop Vacuum Hose Adapter with Mounting Tab
- (1) Shop Vacuum Canister Adapter



### HOSES

#### 2½" HOSE

- 81201** ■  
(1) 12" Segment\*
- 81202** ■  
(2) 12" Segments
- 89220** ■  
(20) 12" Segments



- \*1 Segment = 9 Elements
- Hose Bending Radius = 5.75"



### CONNECTORS

#### 3" THIN WALL PVC DWV SCH. 30 ADAPTER

- 81206**  
(1) Sch. 30 PVC Adapter
- 89226**  
(10) Sch. 30 PVC Adapters



#### 3" SHEET METAL DUCT ADAPTER

- 81207** ■  
(1) Sheet Metal Duct Adapter
- 89227** ■  
(10) Sheet Metal Duct Adapters

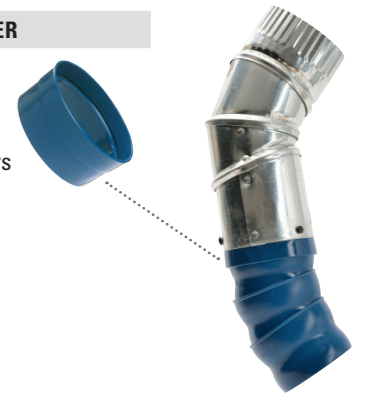

### NOZZLES

#### 4½" ROUND NOZZLE

- 81203** ■  
(1) Round Nozzle
- 89223** ■  
(10) Round Nozzles



#### 6" x 3½" RECTANGULAR NOZZLE

- 81204** ■  
(1) Rectangular Nozzle
- 89224**  
(10) Rectangular Nozzles



#### TAPERED OVAL NOZZLE

- 81205** ■  
(1) Oval Nozzle
- 89225** ■  
(10) Oval Nozzles



### VALVES

#### 2½" SLIDE VALVE

- 81208** ■  
(1) Slide Valve
- 89228** ■  
(10) Slide Valves



### ACCESSORIES

#### SHOP VACUUM HOSE ADAPTER WITH MOUNTING TAB

- 81209** ■  
(1) Shop Vacuum Adapter
- 89229** ■  
(10) Shop Vacuum Adapters



#### SHOP VACUUM CANISTER ADAPTER

- 81210** ■  
(1) Shop Vacuum Canister Adapter
- 89230** ■  
(10) Shop Vacuum Canister Adapters



### ANTI-STATIC

#### 2½" HOSE

- 81301AS** ■  
(1) 12" Anti-Static Segment\*
- 81302AS** ■  
(2) 12" Anti-Static Segments
- 89320AS** ■  
(20) 12" Anti-Static Segments
- \*1 Segment = 9 Elements



#### 4½" ROUND NOZZLE

- 81303AS** ■  
(1) Anti-Static Round Nozzle
- 89323AS** ■  
(10) Anti-Static Round Nozzles



#### 6" x 3½" RECTANGULAR NOZZLE

- 81304AS** ■  
(1) Anti-Static Rectangular Nozzle
- 89324AS** ■  
(10) Anti-Static Rectangular Nozzles



#### TAPERED OVAL NOZZLE

- 81305AS** ■  
(1) Anti-Static Oval Nozzle
- 89325AS** ■  
(10) Anti-Static Oval Nozzles



#### 2½" SLIDE VALVE

- 81308AS** ■  
(1) Anti-Static Slide Valve
- 89328AS** ■  
(10) Anti-Static Slide Valves



#### 3" SHEET METAL DUCT ADAPTER

- 81307AS** ■  
(1) Anti-Static Metal Duct Adapter
- 89327AS** ■  
(10) Anti-Static Metal Duct Adapters





## CT HPT NOZZLES

High Pressure Turret (HPT) Nozzles expand the working pressure range to a maximum 1,000 PSI, allowing a higher level of machining while providing the same LOC-LINE® quality and ease of control you've come to expect. Maximum operating temperature is 115° F/ 46° C.

The CT (Compact Turret) style nozzle is designed for tight spaces, from 0 to 1000 PSI.

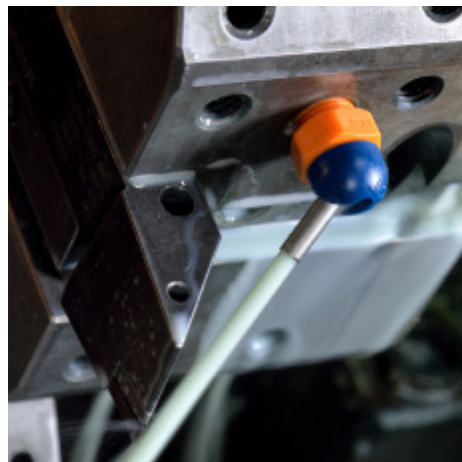

### TECH SPECS

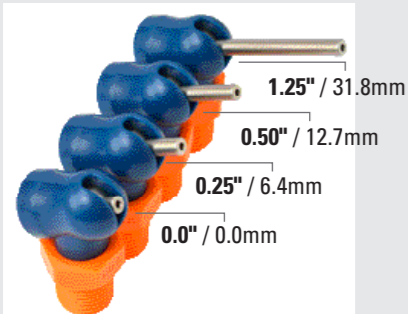

FOUR NOZZLE LENGTHS Available on both CT and XR Nozzles

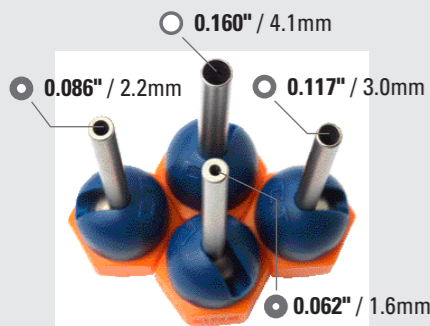

Available on both CT and XR Nozzles

10 PC. PACKAGES ARE AVAILABLE IN BLACK AND GRAY. TO ORDER BLACK OR GRAY LOC-LINE:  
 -BLK Part can be ordered in Black. Add suffix to part number when ordering, ie: 49421-BLK  
 -G Part can be ordered in Gray. Add suffix to part number when ordering, ie: 49421-G

### 1/8" NPT/BSPT THREAD CT STYLE NOZZLES

#### 0.0" NOZZLE LENGTH

- 72010 (2) Nozzles, 0.062"  $\varnothing$  ●
- 79010 (10) Nozzles, 0.062"  $\varnothing$  -BLK -G ●
- 72014 (2) Nozzles, 0.086"  $\varnothing$  ●
- 79014 (10) Nozzles, 0.086"  $\varnothing$  -BLK -G ●
- 72018 (2) Nozzles, 0.117"  $\varnothing$  ○
- 79018 (10) Nozzles, 0.117"  $\varnothing$  -BLK -G ○
- 72022 (2) Nozzles, 0.160"  $\varnothing$  ○
- 79022 (10) Nozzles, 0.160"  $\varnothing$  -BLK -G ○

#### 0.25" NOZZLE LENGTH

- 72011 (2) Nozzles, 0.062"  $\varnothing$  ●
- 79011 (10) Nozzles, 0.062"  $\varnothing$  -BLK -G ●
- 72015 (2) Nozzles, 0.086"  $\varnothing$  ●
- 79015 (10) Nozzles, 0.086"  $\varnothing$  -BLK -G ●
- 72019 (2) Nozzles, 0.117"  $\varnothing$  ○
- 79019 (10) Nozzles, 0.117"  $\varnothing$  -BLK -G ○
- 72023 (2) Nozzles, 0.160"  $\varnothing$  ○
- 79023 (10) Nozzles, 0.160"  $\varnothing$  -BLK -G ○

#### 0.5" NOZZLE LENGTH

- 72012 (2) Nozzles, 0.062"  $\varnothing$  ●
- 79012 (10) Nozzles, 0.062"  $\varnothing$  -BLK -G ●
- 72016 (2) Nozzles, 0.086"  $\varnothing$  ●
- 79016 (10) Nozzles, 0.086"  $\varnothing$  -BLK -G ●
- 72020 (2) Nozzles, 0.117"  $\varnothing$  ○
- 79020 (10) Nozzles, 0.117"  $\varnothing$  -BLK -G ○
- 72024 (2) Nozzles, 0.160"  $\varnothing$  ○
- 79024 (10) Nozzles, 0.160"  $\varnothing$  -BLK -G ○

#### 1.25" NOZZLE LENGTH

- 72013 (2) Nozzles, 0.062"  $\varnothing$  ●
- 79013 (10) Nozzles, 0.062"  $\varnothing$  -BLK -G ●
- 72017 (2) Nozzles, 0.086"  $\varnothing$  ●
- 79017 (10) Nozzles, 0.086"  $\varnothing$  -BLK -G ●
- 72021 (2) Nozzles, 0.117"  $\varnothing$  ○
- 79021 (10) Nozzles, 0.117"  $\varnothing$  -BLK -G ○
- 72025 (2) Nozzles, 0.160"  $\varnothing$  ○
- 79025 (10) Nozzles, 0.160"  $\varnothing$  -BLK -G ○

### 1/4" NPT/BSPT THREAD CT STYLE NOZZLES

#### 0.0" NOZZLE LENGTH

- 72060 (2) Nozzles, 0.062"  $\varnothing$  ●
- 79060 (10) Nozzles, 0.062"  $\varnothing$  -BLK -G ●
- 72064 (2) Nozzles, 0.086"  $\varnothing$  ●
- 79064 (10) Nozzles, 0.086"  $\varnothing$  -BLK -G ●
- 72068 (2) Nozzles, 0.117"  $\varnothing$  ○
- 79068 (10) Nozzles, 0.117"  $\varnothing$  -BLK -G ○
- 72072 (2) Nozzles, 0.160"  $\varnothing$  ○
- 79072 (10) Nozzles, 0.160"  $\varnothing$  -BLK -G ○

#### 0.25" NOZZLE LENGTH

- 72061 (2) Nozzles, 0.062"  $\varnothing$  ●
- 79061 (10) Nozzles, 0.062"  $\varnothing$  -BLK -G ●
- 72065 (2) Nozzles, 0.086"  $\varnothing$  ●
- 79065 (10) Nozzles, 0.086"  $\varnothing$  -BLK -G ●
- 72069 (2) Nozzles, 0.117"  $\varnothing$  ○
- 79069 (10) Nozzles, 0.117"  $\varnothing$  -BLK -G ○
- 72073 (2) Nozzles, 0.160"  $\varnothing$  ○
- 79073 (10) Nozzles, 0.160"  $\varnothing$  -BLK -G ○

#### 0.5" NOZZLE LENGTH

- 72062 (2) Nozzles, 0.062"  $\varnothing$  ●
- 79062 (10) Nozzles, 0.062"  $\varnothing$  -BLK -G ●
- 72066 (2) Nozzles, 0.086"  $\varnothing$  ●
- 79066 (10) Nozzles, 0.086"  $\varnothing$  -BLK -G ●
- 72070 (2) Nozzles, 0.117"  $\varnothing$  ○
- 79070 (10) Nozzles, 0.117"  $\varnothing$  -BLK -G ○
- 72074 (2) Nozzles, 0.160"  $\varnothing$  ○
- 79074 (10) Nozzles, 0.160"  $\varnothing$  -BLK -G ○

#### 1.25" NOZZLE LENGTH

- 72063 (2) Nozzles, 0.062"  $\varnothing$  ●
- 79063 (10) Nozzles, 0.062"  $\varnothing$  -BLK -G ●
- 72067 (2) Nozzles, 0.086"  $\varnothing$  ●
- 79067 (10) Nozzles, 0.086"  $\varnothing$  -BLK -G ●
- 72071 (2) Nozzles, 0.117"  $\varnothing$  ○
- 79071 (10) Nozzles, 0.117"  $\varnothing$  -BLK -G ○
- 72075 (2) Nozzles, 0.160"  $\varnothing$  ○
- 79075 (10) Nozzles, 0.160"  $\varnothing$  -BLK -G ○



The XR (Extended Rotation) style nozzle features a wide nozzle swing and the ability to aim coolant below the horizontal plane, from 0 to 1000 PSI.



## LOC-LINE

### 1/8" NPT/BSPT THREAD XR STYLE NOZZLES

#### 0.0" NOZZLE LENGTH

- 72040 (2) Nozzles, 0.062"  $\varnothing$  ●
- 79040 (10) Nozzles, 0.062"  $\varnothing$  -BLK -G ●
- 72044 (2) Nozzles, 0.086"  $\varnothing$  ●
- 79044 (10) Nozzles, 0.086"  $\varnothing$  -BLK -G ●
- 72048 (2) Nozzles, 0.117"  $\varnothing$  ○
- 79048 (10) Nozzles, 0.117"  $\varnothing$  -BLK -G ○
- 72052 (2) Nozzles, 0.160"  $\varnothing$  ○
- 79052 (10) Nozzles, 0.160"  $\varnothing$  -BLK -G ○

#### 0.5" NOZZLE LENGTH

- 72042 (2) Nozzles, 0.062"  $\varnothing$  ●
- 79042 (10) Nozzles, 0.062"  $\varnothing$  -BLK -G ●
- 72046 (2) Nozzles, 0.086"  $\varnothing$  ●
- 79046 (10) Nozzles, 0.086"  $\varnothing$  -BLK -G ●
- 72050 (2) Nozzles, 0.117"  $\varnothing$  ○
- 79050 (10) Nozzles, 0.117"  $\varnothing$  -BLK -G ○
- 72054 (2) Nozzles, 0.160"  $\varnothing$  ○
- 79054 (10) Nozzles, 0.160"  $\varnothing$  -BLK -G ○

#### 0.25" NOZZLE LENGTH

- 72041 (2) Nozzles, 0.062"  $\varnothing$  ●
- 79041 (10) Nozzles, 0.062"  $\varnothing$  -BLK -G ●
- 72045 (2) Nozzles, 0.086"  $\varnothing$  ●
- 79045 (10) Nozzles, 0.086"  $\varnothing$  -BLK -G ●
- 72049 (2) Nozzles, 0.117"  $\varnothing$  ○
- 79049 (10) Nozzles, 0.117"  $\varnothing$  -BLK -G ○
- 72053 (2) Nozzles, 0.160"  $\varnothing$  ○
- 79053 (10) Nozzles, 0.160"  $\varnothing$  -BLK -G ○

#### 1.25" NOZZLE LENGTH

- 72043 (2) Nozzles, 0.062"  $\varnothing$  ●
- 79043 (10) Nozzles, 0.062"  $\varnothing$  -BLK -G ●
- 72047 (2) Nozzles, 0.086"  $\varnothing$  ●
- 79047 (10) Nozzles, 0.086"  $\varnothing$  -BLK -G ●
- 72051 (2) Nozzles, 0.117"  $\varnothing$  ○
- 79051 (10) Nozzles, 0.117"  $\varnothing$  -BLK -G ○
- 72055 (2) Nozzles, 0.160"  $\varnothing$  ○
- 79055 (10) Nozzles, 0.160"  $\varnothing$  -BLK -G ○

### 1/4" NPT/BSPT THREAD XR STYLE NOZZLES

#### 0.0" NOZZLE LENGTH

- 72080 (2) Nozzles, 0.062"  $\varnothing$  ●
- 79080 (10) Nozzles, 0.062"  $\varnothing$  -BLK -G ●
- 72084 (2) Nozzles, 0.086"  $\varnothing$  ●
- 79084 (10) Nozzles, 0.086"  $\varnothing$  -BLK -G ●
- 72088 (2) Nozzles, 0.117"  $\varnothing$  ○
- 79088 (10) Nozzles, 0.117"  $\varnothing$  -BLK -G ○
- 72092 (2) Nozzles, 0.160"  $\varnothing$  ○
- 79092 (10) Nozzles, 0.160"  $\varnothing$  -BLK -G ○

#### 0.5" NOZZLE LENGTH

- 72082 (2) Nozzles, 0.062"  $\varnothing$  ●
- 79082 (10) Nozzles, 0.062"  $\varnothing$  -BLK -G ●
- 72086 (2) Nozzles, 0.086"  $\varnothing$  ●
- 79086 (10) Nozzles, 0.086"  $\varnothing$  -BLK -G ●
- 72090 (2) Nozzles, 0.117"  $\varnothing$  ○
- 79090 (10) Nozzles, 0.117"  $\varnothing$  -BLK -G ○
- 72094 (2) Nozzles, 0.160"  $\varnothing$  ○
- 79094 (10) Nozzles, 0.160"  $\varnothing$  -BLK -G ○

#### 0.25" NOZZLE LENGTH

- 72081 (2) Nozzles, 0.062"  $\varnothing$  ●
- 79081 (10) Nozzles, 0.062"  $\varnothing$  -BLK -G ●
- 72085 (2) Nozzles, 0.086"  $\varnothing$  ●
- 79085 (10) Nozzles, 0.086"  $\varnothing$  -BLK -G ●
- 72089 (2) Nozzles, 0.117"  $\varnothing$  ○
- 79089 (10) Nozzles, 0.117"  $\varnothing$  -BLK -G ○
- 72093 (2) Nozzles, 0.160"  $\varnothing$  ○
- 79093 (10) Nozzles, 0.160"  $\varnothing$  -BLK -G ○

#### 1.25" NOZZLE LENGTH

- 72083 (2) Nozzles, 0.062"  $\varnothing$  ●
- 79083 (10) Nozzles, 0.062"  $\varnothing$  -BLK -G ●
- 72087 (2) Nozzles, 0.086"  $\varnothing$  ●
- 79087 (10) Nozzles, 0.086"  $\varnothing$  -BLK -G ●
- 72091 (2) Nozzles, 0.117"  $\varnothing$  ○
- 79091 (10) Nozzles, 0.117"  $\varnothing$  -BLK -G ○
- 72095 (2) Nozzles, 0.160"  $\varnothing$  ○
- 79095 (10) Nozzles, 0.160"  $\varnothing$  -BLK -G ○

### NOZZLE ADJUSTMENT LEVER

#### ADJUSTMENT LEVERS

- 72000 (2) Adjustment Levers
- 79000 (10) Adjustment Levers

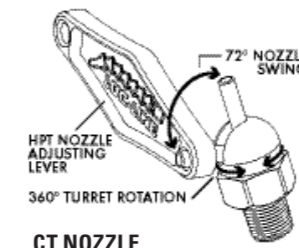

CT NOZZLE ADJUSTMENT

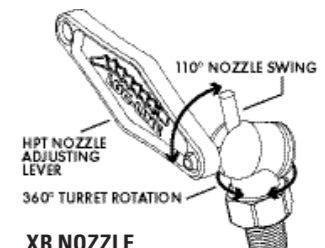

XR NOZZLE ADJUSTMENT

1/4" ACID RESISTANT

1/4" ACID RESISTANT HOSE KIT

- 45463 (2) 5/8" Long Segments
- (1) 1/4" Nozzle
- (1) 1/8" Nozzle
- (1) 1/16" Nozzle
- (1) 1/4" NPT Connector
- (1) 1/8" NPT Connector

1/4" ACID RESISTANT HOSE

- 45401 (2) 5/8" Long Segments
- 46420 (55) Segments, Bulk 25-ft
- 46419 (1) 5 ft Coil
- 46421 (1) 50 ft Coil

1/16" ACID RESISTANT NOZZLE

- 45402 (4) Round Nozzles
- 46422 (50) Round Nozzles

1/8" ACID RESISTANT NOZZLE

- 45403 (4) Round Nozzles
- 46423 (50) Round Nozzles

1/4" ACID RESISTANT NOZZLE

- 45404 (4) Round Nozzles
- 46424 (50) Round Nozzles



1" ACID RESISTANT FLARE NOZZLE

- 45407 (2) Flare Nozzles
- 46427 (20) Flare Nozzles

1/8" ACID RESISTANT NPT CONNECTOR

- 45405 (4) NPT Connectors
- 46425 (50) NPT Connectors

1/4" ACID RESISTANT NPT CONNECTOR

- 45406 (4) NPT Connectors
- 46426 (50) NPT Connectors

1/4" ACID RESISTANT Y

- 45408 (2) Y's
- 46428 (20) Y's

1/4" ACID RESISTANT DOUBLE SOCKET

- 45409 (4) Double Sockets
- 46429 (20) Double Sockets

1/4" SOCKET X 1/8" FNPT ACID RESISTANT

- 45411 (4) 1/4" Socket X 1/8" FNPT
- 46431 (20) 1/4" Socket X 1/8" FNPT

1/4" ACID RESISTANT ELBOW

- 45415 (2) Elbows
- 46435 (20) Elbows

1/4" ACID RESISTANT T

- 45416 (2) T's
- 46436 (20) T's

1/4" ACID RESISTANT SWIVEL NOZZLE 40

- 45481 (2) Swivel Nozzles
- 46449 (20) Swivel Nozzles

1/4" ACID RESISTANT SWIVEL NOZZLE 60

- 45482 (2) Swivel Nozzles
- 46450 (20) Swivel Nozzles

- Loc-Line® Acid Resistant Hose is excellent for rinsing cycles in plating operations.
- Acid environments won't corrode the Loc-Line® Acid Resistant Hose because of its polyester composition. **CAUTION:** Loc-Line® Acid Resistant Hose is not intended for conveying acids or high pressure applications.

1/2" ACID RESISTANT

1/2" ACID RESISTANT HOSE KIT

- 56863 (2) 5/8" Long Segments
- (1) 1/4" Round Nozzle
- (1) 3/8" Round Nozzle
- (1) 1/2" Round Nozzle
- (1) 3/8" NPT Connector
- (1) 1/2" NPT Connector

1/2" ACID RESISTANT HOSE

- 56801 (2) 5/8" Long Segments
- 57860 (59) Segments, Bulk 25 ft
- 57859 (1) 5 ft Coil
- 57861 (1) 50 ft Coil

1/4" ACID RESISTANT NOZZLE

- 56806 (4) Round Nozzles
- 57866 (50) Round Nozzles

3/8" ACID RESISTANT NOZZLE

- 56802 (4) Round Nozzles
- 57862 (50) Round Nozzles

1/2" ACID RESISTANT NOZZLE

- 56803 (4) Round Nozzles
- 57863 (50) Round Nozzles

3/8" ACID RESISTANT NPT

- 56804 (4) NPT Connectors
- 57864 (50) NPT Connectors

1/2" ACID RESISTANT NPT

- 56805 (4) NPT Connectors
- 57865 (50) NPT Connectors

1/4" ACID RESISTANT FLARE NOZZLE

- 56807 (2) Flare Nozzles
- 57867 (20) Flare Nozzles

1/2" ACID RESISTANT Y

- 56808 (2) Y's
- 57868 (20) Y's

1/2" TO 1/4" ACID RESISTANT Y REDUCER

- 56822 (2) Y Reducers
- 57870 (20) Reducers

1/2" TO 1/4" ACID RESISTANT REDUCER

- 56821 (2) Reducers
- 57869 (20) Reducers

1/2" ACID RESISTANT ELBOW

- 56824 (2) Elbows
- 57874 (20) Elbows

1/2" ACID RESISTANT T

- 56825 (2) T's
- 57875 (20) T's

1/2" DOUBLE SOCKET

- 56811 (4) Double Sockets
- 57872 (20) Double Sockets

TEFEN™ COUPLINGS

Tefen™ products change threaded male components to female threads. Tefen products are made in Israel.

1/8" FEMALE PIPE COUPLING

- 40656 (4) Female Pipe Couplings
- 41756 (20) Female Pipe Couplings

1/4" FEMALE PIPE COUPLING

- 40657 (4) Female Pipe Couplings
- 41757 (20) Female Pipe Couplings

3/8" FEMALE PIPE COUPLING

- 50660 (4) Female Pipe Couplings
- 51760 (20) Female Pipe Couplings

1/2" FEMALE PIPE COUPLING

- 50661 (4) Female Pipe Couplings
- 51761 (20) Female Pipe Couplings

1/4" PIPE PLUG

- 40654 (4) Pipe Plug
- 41754 (20) Pipe Plug

1/4" TO 1/8" FEMALE PIPE REDUCER

- 40655 (4) Female Pipe Reducers
- 41755 (20) Female Pipe Reducers

3/8" TO 1/4" FEMALE PIPE REDUCER

- 50658 (4) Female Pipe Reducers
- 51758 (20) Female Pipe Reducers

1/2" TO 1/4" FEMALE PIPE REDUCER

- 50659 (4) Female Pipe Reducers
- 51759 (20) Female Pipe Reducers



## SILVER STEEL

Part No	Diameter
SS1.5	1.5mm
SS2	2mm
SS2.5	2.5mm
SS3	3mm
SS3.5	3.5mm
SS4	4mm
SS4.5	4.5mm
SS5	5mm
SS5.5	5.5mm
SS6	6mm
SS6.5	6.5mm
SS7	7mm
SS7.5	7.5mm
SS8	8mm
SS9	9mm
SS9.5	9.5mm
SS10	10mm
SS10.5	10.5mm
SS11	11mm
SS12	12mm
SS12.5	12.5mm
SS13	13mm
SS14	14mm
SS15	15mm
SS16	16mm
SS17	17mm
SS18	18mm
SS19	19mm
SS20	20mm
SS21	21mm
SS22	22mm
SS23	23mm
SS24	24mm
SS25	25mm
SS26	26mm
SS27	27mm
SS28	28mm

SS29	29mm
SS30	30mm
SS31	31mm
SS32	32mm
SS33	33mm
SS34	34mm
SS35	35mm
SS36	36mm
SS37	37mm
SS38	38mm
SS39	39mm
SS40	40mm
SS45	45mm
SS50	50mm

Part No	Diameter
SS1/16	1/16"
SS3/32	3/32"
SS1/8	1/8"
SS5/32	5/32"
SS3/16	3/16"
SS7/32	7/32"
SS1/4	1/4"
SS9/32	9/32"
SS5/16	5/16"
SS11/32	11/32"
SS3/8	3/8"

SS13/32	13/32"
SS7/16	7/16"
SS15/32	15/32"
SS1/2	1/2"
SS9/16	9/16"
SS19/32	19/32"
SS5/8	5/8"
SS21/32	21/32"
SS11/16	11/16"

SS3/4	3/4"
SS13/16	13/16"
SS7/8	7/8"
SS15/16	15/16"
SS1INCH	1"
SS1-1/8	1-1/8"
SS1-1/4	1-1/4"
SS1-3/8	1-3/8"
SS1-1/2	1-1/2"
SS1-3/4	1-3/4"
SS2INCH	2"



**ALL METRIC & IMPERIAL SILVER STEEL ARE 1 METRE IN LENGTH, ROUND & WATER HARDENING.**

**Manufactured to BS1407:1970**  
**1" and above, plus or minus 0.0005"**  
**below 1" plus or minus 0.0003"**  
**Over 25mm, +0.00mm -0.02mm**  
**25mm and below, +0.00mm -0.01mm**



Size	Part No.
M3 x 0.5	CDT3M
M4 x 0.7	CDT4M
M5 x 0.8	CDT5M
M6 x 1.0	CDT6M
M8 x 1.25	CDT8M
M10 x 1.5	CDT10M



## ROUND - METRIC

### HSS COMBINATION DRILL & TAP

Drill & Tap in one operation using either a portable power tool or a stationary drilling machine such as a pedestal drill. Back taper beyond tap helps prevent thread damage from over drilling

1/4" hex shank ensures strong connection to the drill chuck

Designed to drill and tap through-holes up to 2X nominal diameter. Drill point must break through the part prior to threading. Applications include Electrical, Construction, Plumbing, Automotive, Cabinet Makers, Heating Ventilation & Air Conditioning installers.

## ROUND - IMPERIAL



## HIGH PRECISION TORQUE CONTROL TOOLS

### WIHA TORQUEFIX®

The TorqueFix® has one, customer provided, torque value preset by Wiha. It's the ideal tool for use in a single application which always requires the same torque to be applied. Use in oily work environments is also not a problem, e.g. for tightening inserts. Wiha TorqueFix® is available in the ranges 0.15 Nm up to 7.2Nm



### Series 2850 TorqueFix®

Part number	Nm
26890	0.15
26127	0.5
26047	0.6
26048	0.9
26133	1.1
26051	2.0
26128	2.5
26052	3.0
26129	3.8
26130	5.5
26131	7.2

### WIHA TORQUEVARIO®-S

The variable tool for a variety of tasks. Also suitable for oily work places or environments. An included adjustment tool and an integrated window scale allow for the easy adjustment and reading of torque values. All together the user can choose from five models covering the ranges from 0.1Nm to 8.0Nm.



### Series 2852 TorqueVario®-S with window scale

Part number	Nm
26888	0.1 - 0.6
26461	0.4 - 1.0
26462	0.8 - 2.0
26463	1.0 - 5.0
26464	2.0 - 8.0

Set contains TorqueVario®-S tool with window scale  
 Range 1.0 - 5.0 Nm. Sturdy metal container  
 Torque setter, 1/4" hex Universal bit holder  
 1/4" hex bits PH 1, PH 2, PZ 1, PZ 2  
 T10, T15, T20, T25, 2.5mm hex, 3mm hex  
 Part number 26893



### WIHA INTERCHANGEABLE BLADE SYSTEM

#### Series 2859

Part No	Drive	Nm. max
26199	PH 000	0.4
26196	PH 00	0.4
26197	PH 0	0.9
26058	PH 1	3.8
27079	PH 2	5.9
26198	PZ 0	0.9
26148	PZ 1	3.8
26889	PZ 2	5.5
26200	Hex 1.5	0.9
26060	Hex 2	1.8
26061	Hex 2.5	3.8
26062	Hex 3	8.0
26063	Hex 4	8.0
27526	Universal to hold 1/4" hex	
26864	Torque setter	

#### Series 2859

Part No	Drive	Nm. max
26158	Torx T5	0.4
26064	Torx T6	0.6
26065	Torx T7	0.9
26066	Torx T8	1.3
26059	Torx T9	2.5
26067	Torx T10	3.8
26068	Torx T15	5.5
26069	Torx T20	8.0
26070	Torx T25	8.0
26073	Torx Plus 15IP	5.5
26229	For 1/4" square nuts	



*These parts have no connection with the proprietors of the registered trademarks. Phillips® & Pozidriv® are registered trademarks of the Phillips Screw Company*

**7049XH Series**  
Xeno Bits for terminal screws  
Combination profile reduces slipping and ensures greater torque transfer.  
Specifically designed for use with switch cabinet systems and fuse boxes, terminal blocks and relays.



Drive	Length	Wiha P/N
Phillips® 2	50mm	32492

### 7011 ZOT Series

Drive	Length	Wiha P/N
Phillips® 2	25mm	05076



### 7012 Z Series

Drive	Length	Wiha P/N
PoziDriv® 0	25mm	05300
PoziDriv® 1	25mm	01688
PoziDriv® 2	25mm	01689
PoziDriv® 3	25mm	01690
PoziDriv® 4	32mm	01681



### 7042 ZOT Series - Features Optimised Torsion Zone

Drive	Length	Wiha P/N
PoziDriv® 1	50mm	04547
PoziDriv® 2	50mm	04546
PoziDriv® 3	50mm	04545



### 7042 Z Series

Drive	Length	Wiha P/N
PoziDriv® 1	89mm	01809
PoziDriv® 2	89mm	01812
PoziDriv® 2	152mm	23228
PoziDriv® 3	89mm	04176



**Series 7210 Adapter**  
1/4" square to 1/4" hex  
Part number 01933



### 7011 Z Series

Drive	Length	Wiha P/N
Phillips® 0	25mm	05298
Phillips® 1	25mm	01657
Phillips® 2	25mm	01658
Phillips® 3	25mm	01659
Phillips® 4	32mm	01649



### 7041 ZOT Series

Drive	Length	Wiha P/N
Phillips® 1	50mm	33730
Phillips® 2	50mm	33704
Phillips® 3	50mm	33705



### 7041 Z Series

Drive	Length	Wiha P/N
Phillips® 1	90mm	04126
Phillips® 1	152mm	22509
Phillips® 2	90mm	04009
Phillips® 2	152mm	22510
Phillips® 3	89mm	04127



**Series 384 Bit Holder**  
Ergonomic handle. 300mm blade length, 418mm overall  
accepts all 1/4" hex bits  
Part Number 01476



### 7113 S Series

Description	Wiha P/N
Bit holder 2 piece magnetic 59mm overall length	01895
Bit Holder 2 piece magnetic 74mm overall length	01894



### Dimensions of profiles - Torx® (mm)

<b>TX 1</b>	0.84	<b>TX 20</b>	3.84
<b>TX 2</b>	0.94	<b>TX 25</b>	4.40
<b>TX 3</b>	1.12	<b>TX 27</b>	4.96
<b>TX 4</b>	1.30	<b>TX 30</b>	5.49
<b>TX 5</b>	1.37	<b>TX 40</b>	6.60
<b>TX 6</b>	1.65	<b>TX 45</b>	7.77
<b>TX 7</b>	1.97	<b>TX 50</b>	8.79
<b>TX 8</b>	2.30	<b>TX 55</b>	11.17
<b>TX 9</b>	2.48	<b>TX 60</b>	13.20
<b>TX 10</b>	2.72	<b>TX 70</b>	15.49
<b>TX 15</b>	3.26		



### 7015 ZTR Series

Drive	Length	Wiha P/N
Torx® security TR 7	25mm	03115
Torx® security TR 8	25mm	03117
Torx® security TR 9	25mm	01726
Torx® security TR 10	25mm	01727
Torx® security TR 15	25mm	01728
Torx® security TR 20	25mm	01729
Torx® security TR 25	25mm	01730
Torx® security TR 27	25mm	01731
Torx® security TR30	25mm	01732
Torx® security TR 40	25mm	01733



### 7045 TR Series

Drive	Length	Wiha P/N
Torx® security TR 7	50mm	21045
Torx® security TR 8	50mm	21047
Torx® security TR 9	50mm	20218
Torx® security TR 10	50mm	20219
Torx® security TR 15	50mm	24867
Torx® security TR 20	50mm	20220
Torx® security TR 25	50mm	20221
Torx® security TR 27	50mm	20222
Torx® security TR 30	50mm	20223
Torx® security TR 40	50mm	20224



### 7046 Z Series

Drive	Length	Wiha P/N
Torx-Plus® IP 6	50mm	26000
Torx-Plus® IP 7	50mm	26002
Torx-Plus® IP 8	50mm	23195
Torx-Plus® IP 9	50mm	23197
Torx-Plus® IP 10	50mm	23199
Torx-Plus® IP 15	50mm	23201
Torx-Plus® IP 20	50mm	23203
Torx-Plus® IP 25	50mm	23205
Torx-Plus® IP 27	50mm	23207
Torx-Plus® IP 30	50mm	23209
Torx-Plus® IP 40	50mm	23211



*These parts have no connection with the proprietors of the registered trademarks. Torx® is a registered trademark of Camcar Division of Textron.TriWing® is a registered trademark of G.K.N. Screws and Fasteners Ltd.*



### 7015 Z Series

Drive	Length	Wiha P/N
Torx® TX 3	25mm	26250
Torx® TX 4	25mm	25097
Torx® TX 5	25mm	01711
Torx® TX 6	25mm	01712
Torx® TX 7	25mm	01713
Torx® TX 8	25mm	01714
Torx® TX 9	25mm	01715
Torx® TX 10	25mm	01716
Torx® TX 15	25mm	01717
Torx® TX 20	25mm	01718
Torx® TX 25	25mm	01719
Torx® TX 27	25mm	01720
Torx® TX 30	25mm	01721
Torx® TX 40	25mm	01722
Torx® TX 45	35mm	01723
Torx® TX 50	35mm	01724



Note TX 55 is Series 7025 Z with a 5/16" hex

### 7045 Z Series & 7045 ZL Series

Drive	Length	Wiha P/N
Torx® TX 5	50mm	32299
Torx® TX 6	50mm	32302
Torx® TX 7	50mm	32303
Torx® TX 8	50mm	32304
Torx® TX 9	50mm	32305
Torx® TX 10	50mm	32306
Torx® TX 10	150mm	33726
Torx® TX 15	50mm	32307
Torx® TX 15	90mm	33722
Torx® TX 15	150mm	33728
Torx® TX 20	50mm	32308
Torx® TX 25	50mm	32309
Torx® TX 25	150mm	23249
Torx® TX 27	50mm	33920
Torx® TX 27	90mm	33922
Torx® TX 30	50mm	33923
Torx® TX 30	90mm	33925
Torx® TX 30	150mm	33927
Torx® TX 40	50mm	33928
Torx® TX 40	90mm	33930
Torx® TX 40	150mm	33932





7010 Z Series



Drive	Length	Wiha P/N
Slotted 4.5 x 0.6	25mm	01623
Slotted 5.5 x 0.8	25mm	01624
Slotted 6.5 x 1.2	25mm	01626
Slotted 8.0 x 1.6	25mm	01627
Slotted 6.5 x 1.2	50mm	01798

7019 TW ZOT Series - Features optimised Torsion Zone



Drive	Length	Wiha P/N
Tri-Wing® 0	25mm	22603
Tri-Wing® 1	25mm	22604
Tri-Wing® 2	25mm	22605
Tri-Wing® 3	25mm	22606
Tri-Wing® 4	25mm	22607
Tri-Wing® 5	25mm	22608

7019 TS ZOT Series - Features optimised Torsion Zone



Drive	Length	Wiha P/N
Torq-Set 2	25mm	26249
Torq-Set 3	25mm	26045
Torq-Set 4	25mm	22591
Torq-Set 5	25mm	22592
Torq-Set 6	25mm	22593
Torq-Set 8	25mm	22594
Torq-Set 10	25mm	22595

7018 Z Series



Drive	Length	Wiha P/N
Square 1 (3/32)	25mm	06634
Square 2 (1/8)	25mm	06635
Square 3 (9/64)	25mm	06636

Square is sometimes referred to as Robinson

7019 SP Series



Drive	Length	Wiha P/N
Pin Spanner 4	25mm	27064
Pin Spanner 6	25mm	27065
Pin Spanner 8	25mm	27066
Pin Spanner 10	25mm	27067

7013 TR Series



Drive	Length	Wiha P/N
Allen Hex security 2mm	25mm	25560
Allen Hex security 2.5mm	25mm	25561
Allen Hex security 3mm	25mm	25562
Allen Hex security 4mm	25mm	25563
Allen Hex security 5mm	25mm	25564

7017 Z Series



Drive	Length	Wiha P/N
Ballpoint Hex 1.5mm	38mm	01734
Ballpoint Hex 2mm	38mm	01735
Ballpoint Hex 2.5mm	38mm	01736
Ballpoint Hex 3mm	38mm	01737
Ballpoint Hex 4mm	38mm	01738
Ballpoint Hex 5mm	38mm	01739
Ballpoint Hex 6mm	38mm	01740

7013 Z Series



Drive	Length	Wiha P/N
Allen Hex 1.5mm	25mm	04011
Allen Hex 2mm	25mm	01703
Allen Hex 2.5mm	25mm	01704
Allen Hex 3mm	25mm	01705
Allen Hex 4mm	25mm	01706
Allen Hex 5mm	25mm	01707
Allen Hex 6mm	25mm	01708
Allen Hex 8mm	25mm	01709
Allen Hex 10mm	25mm	01710

7043 Z Series



Drive	Length	Wiha P/N
Allen Hex 1.5mm	50mm	05301
Allen Hex 2mm	50mm	05302
Allen Hex 2.5mm	50mm	05303
Allen Hex 3mm	50mm	04194
Allen Hex 4mm	50mm	04195
Allen Hex 5mm	50mm	04196
Allen Hex 6mm	50mm	04197



CUTTING FLUIDS

TAP MAGIC® WITH EP-XTRA -

The original formula minus 1.1.1 Trichloroethane. Now an ozone friendly formula that gives you outstanding performance for any cutting operation on any metal. Absolutely without equal on all hard metals and for cuts of extreme pressure or for long duration.

Part No.	Description
10004E	Tap Magic® EP-Xtra 4 oz (120ml) spout top <b>plastic bottle (box qty: 24)</b>
10012EL	Tap Magic® EP-Xtra 12 oz (354 gram) <b>aerosol can (box qty: 12)</b>
10016E	Tap Magic® EP-Xtra 16 oz (472 ml) spout top <b>plastic bottle (box qty: 12)</b>
10050E	Tap Magic® EP-Xtra 5 Litre <b>plastic bottle</b>
10025E	Tap Magic® EP-Xtra 25 Litre <b>plastic container</b>

TAP MAGIC® XTRA-THICK -

The extreme performance heavyweight cutting fluid for the hardest metals up to 45 RC. Great for lathe, millwork, and deep hole cuts. Very effective on stainless steel. Contains EP-Xtra.

Part No.	Description
70016T	Tap Magic® EP-Xtra -Thick 16 oz (472 ml) spout top can <b>plastic bottle (box qty: 12)</b>

TAP MAGIC® ALUMINIUM -

the most effective cutting fluid you can use for any metal work on aluminium. Provides excellent performance for all cutting operations.

Part No.	Description
20004A	Tap Magic® Aluminium 4 oz (120ml) <b>spout top can (box qty: 24)</b>
20016A	Tap Magic® Aluminium 16 oz (472 ml) <b>spout top can (box qty: 12)</b>
20050A	Tap Magic® Aluminium 5 Litre <b>plastic bottle</b>

TAP MAGIC® MULTI PURPOSE CLEANER / DEGREASER-

The second step in any machining process is to remove any oils or debris from the tools or parts. This foaming, water-based cleaner removes fluid, grease, dirt and coolant from your tools, equipment, and parts.

Part No.	Description
90019CTC	Tap Magic® Net 19oz Multi Purpose Cleaner / Degreaser <b>aerosol can (box qty: 12)</b>

TAP MAGIC® CORROSION INHIBITOR -

The final step before putting your tools away or sending parts out to your customers, this inhibitor will protect anything metal around your shop, outside or in! Stops corrosion and displaces moisture in a non-sticky, non-drying formula.

Part No.	Description
90015CTP	Tap Magic® Net 15oz Corrosion Inhibitor <b>aerosol can (box qty: 12)</b>

TAP MAGIC® H2OX -

Tap Magic H2OX™ is formulated to provide excellent lubricity while eliminating the sticky messy film associated with heavy oil products.

Part No.	Description
80005WS	Tap Magic® 5 Litre Fluid Metal Semi-Synthetic H2OX <b>plastic bottle</b>
80640WS	Tap Magic® 18.9L Fluid Metal Semi-Synthetic H2OX <b>plastic container</b>

These parts have no connection with the proprietors of the registered trademarks. Torx® is a registered trademark of Camcar Division of Textron Phillips® and PoziDriv® are registered trademarks of the Phillips Screw Company



## STAMPS - LETTER & NUMBER

Manufactured in Germany from bright drawn tool steel.  
 Hardness at the engraving : 58 - 60 HRC & the stamping end 38-46 HRC  
 All stamps designed to be used on steel up to 800 N/mm<sup>2</sup>  
 Number sets include 0 - 9, letter sets A - Z with & symbol

### 9 PIECE NUMBER SETS

Part Number	Character Height	Dimensions
SN01	1mm	6 x 6 x 65mm
SN01.5	1.5mm	6 x 6 x 65mm
SN02	2mm	6 x 6 x 65mm
SN02.5	2.5mm	6 x 6 x 65mm
SN03	3mm	6 x 6 x 65mm
SN04	4mm	7 x 7 x 65mm
SN05	5mm	8 x 8 x 65mm
SN06	6mm	9 x 9 x 75mm
SN07	7mm	11 x 11 x 76mm
SN08	8mm	11 x 11 x 76mm
SN10	10mm	12 x 12 x 80mm
SN12	12mm	14 x 14 x 80mm
SN15	15mm	16 x 16 x 85mm
SN20	20mm	24 x 15 x 100mm
SN25	25mm	28 x 15 x 100mm



### 27 PIECE LETTER SETS

Part Number	Character Height	Dimensions
SL01	1mm	6 x 6 x 65mm
SL01.5	1.5mm	6 x 6 x 65mm
SL02	2mm	6 x 6 x 65mm
SL02.5	2.5mm	6 x 6 x 65mm
SL03	3mm	6 x 6 x 65mm
SL04	4mm	7 x 7 x 65mm
SL05	5mm	8 x 8 x 65mm
SL06	6mm	9 x 9 x 75mm
SL07	7mm	11 x 11 x 76mm
SL08	8mm	11 x 11 x 76mm
SL10	10mm	12 x 12 x 80mm
SL12	12mm	14 x 14 x 80mm
SL15	15mm	16 x 16 x 85mm
SL20	20mm	24 x 15 x 100mm
SL25	25mm	28 x 15 x 100mm

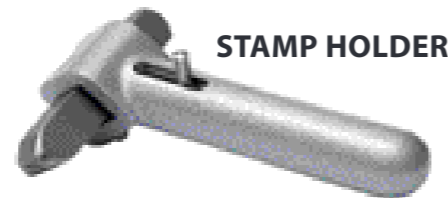

**STAMP HOLDER**

Allows a safe distance between the stamping head and your hand Quick-Change device with spring lock.  
 Will hold stamps with a maximum cross section of 20 x 20mm.

Part Number
HHS

### STAMPS - LETTER & NUMBER - REVERSE

For use in making moulds, the stamps produce reversed impressions, or in sheet metal raising the character in the opposite side.

### 9 PIECE NUMBER SETS

Part Number	Character Height	Dimensions
SNR02	2mm	6 x 6 x 65mm
SNR03	3mm	6 x 6 x 65mm
SNR04	4mm	7 x 7 x 65mm
SNR05	5mm	8 x 8 x 65mm
SNR06	6mm	9 x 9 x 75mm
SNR08	8mm	11 x 11 x 76mm
SNR10	10mm	12 x 12 x 80mm
SNR12	12mm	14 x 14 x 80mm

### 27 PIECE LETTER SETS

Part Number	Character Height	Dimensions
SLR02	2mm	6 x 6 x 65mm
SLR03	3mm	6 x 6 x 65mm
SLR04	4mm	7 x 7 x 65mm
SLR05	5mm	8 x 8 x 65mm
SLR06	6mm	9 x 9 x 75mm
SLR08	8mm	11 x 11 x 76mm
SLR10	10mm	12 x 12 x 80mm
SLR12	12mm	14 x 14 x 80mm

*Individual letter and number stamps are available on request.  
 All stamps are UPPER CASE, lower case are available on special buy-in from Germany*

## STAMPS - LETTER & NUMBER - EXTRA EXTRA

For use on high tensile and hard materials

### 9 PIECE NUMBER SETS

Part Number	Character Height	Dimensions
SNH02	2mm	7 x 7 x 75mm
SNH03	3mm	8 x 8 x 75mm
SNH04	4mm	9 x 9 x 80mm
SNH05	5mm	10 x 10 x 80mm
SNH06	6mm	12 x 12 x 85mm
SNH08	8mm	14 x 14 x 90mm
SNH10	10mm	16 x 16 x 90mm
SNH12	12mm	18 x 18 x 100mm
SNH15	15mm	18 x 18 x 100mm

### 27 PIECE LETTER SETS

Part Number	Character Height	Dimensions
SLH02	2mm	7 x 7 x 75mm
SLH03	3mm	8 x 8 x 75mm
SLH04	4mm	9 x 9 x 80mm
SLH05	5mm	10 x 10 x 80mm
SLH06	6mm	12 x 12 x 85mm
SLH08	8mm	14 x 14 x 90mm
SLH10	10mm	16 x 16 x 90mm
SLH12	12mm	18 x 18 x 100mm
SLH15	15mm	18 x 18 x 100mm

### STAMPS - LETTER & NUMBER - LOW STRESS

Low stress engraving, silky dulled design, for marking gas pipes, weld seams, high pressure pipes, turbines etc

### 9 PIECE NUMBER SETS

Part Number	Character Height	Dimensions
SNLS03	3mm	6 x 6 x 65mm
SNLS04	4mm	7 x 7 x 65mm
SNLS05	5mm	8 x 8 x 65mm
SNLS06	6mm	9 x 9 x 75mm
SNLS08	8mm	11 x 11 x 76mm
SNLS10	10mm	12 x 12 x 80mm



### 27 PIECE LETTER SETS

Part Number	Character Height	Dimensions
SLLS03	3mm	6 x 6 x 65mm
SLLS04	4mm	7 x 7 x 65mm
SLLS05	5mm	8 x 8 x 65mm
SLLS06	6mm	9 x 9 x 75mm
SLLS08	8mm	11 x 11 x 76mm
SLLS10	10mm	12 x 12 x 80mm

### STAMPS - LETTER & NUMBER - DOT LOW STRESS

For use on low impact, low stress dot style engraving, silky dulled design

### 9 PIECE NUMBER SETS

Part Number	Character Height	Dimensions
SND02	2mm	7 x 7 x 75mm
SND03	3mm	8 x 8 x 85mm
SND04	4mm	9 x 9 x 78mm
SND05	5mm	10 x 10 x 78mm
SND06	6mm	12 x 12 x 84mm
SND08	8mm	16 x 16 x 90mm
SND10	10mm	16 x 16 x 90mm
SND12	12mm	16 x 16 x 90mm



### 27 PIECE LETTER SETS

Part Number	Character Height	Dimensions
SLD02	2mm	7 x 7 x 75mm
SLD03	3mm	8 x 8 x 85mm
SLD04	4mm	9 x 9 x 78mm
SLD05	5mm	10 x 10 x 78mm
SLD06	6mm	12 x 12 x 84mm
SLD08	8mm	16 x 16 x 90mm
SLD10	10mm	16 x 16 x 90mm
SLD12	12mm	16 x 16 x 90mm

### TYPE IN FONT SETS - EURO TYPE INTERCHANGEABLE 100 PCE

All sets contain Letters A - Z, Numbers 0 - 9, / slash, comma, full stop, hyphen, spacers, holder, tweezers. All nickel plated

Part Number	Description
S100S01M	1.0mm - 1.5 x 4.0 x 19.00mm - 19pcs Per Holder
S100S1.5M	1.5mm - 1.5 x 4.0 x 19.00mm - 19pcs Per Holder
S100S02M	2.0mm - 2.0 x 4.0 x 19.00mm - 14pcs Per Holder
S100S02.5M	2.5mm - 2.5 x 6.0 x 19.00mm - 15pcs Per Holder
S100S03M	3.0mm - 3.0 x 6.0 x 19.00mm - 13pcs Per Holder
S100S04M	4.0mm - 4.0 x 8.0 x 19.00mm - 10 Pcs Per Holder
S100S05M	5mm - 5.0 x 8.0 x 19.00mm - 8 Pcs Per Holder



Content																																		
A	A	B	B	C	D	D	E	E	E	E	F	F	G	G	H	H	I	I	J	J	K	K	L	L	M	M	N	N	N	O	O	P	P	Q
R	R	R	S	S	S	T	T	T	U	U	U	V	V	V	W	W	X	X	Y	Z	/	,	.	-	-	-	-	-	-	-	-	-	-	-
4	4	5	5	5	6	6	6	7	7	7	8	8	8	9	9	9	0	0	0	0	0	0	0	0	0	0	0	0	0	0	0	0	0	

Additional the Euro Type Font Set contains 6 blank spacers!

## ADJUSTABLE HAND REAMERS

Each reamer expands to the smallest size of the next larger size.

Reamers are used for light cut, repair work, removing stock or simply for enlarging holes.

Reamers can be hand operated with a wrench. Blades are hardened & ground.

The size can be adjusted by moving the blades in tapered slots by means of loosening one nut and tightening the other.

## ADJUSTABLE HAND REAMERS - SETS

Part No.	Description
READSET8A-5A	Set of 4. 8/A to 5/A
READSET4A-M	Set of 16. 4A to M

Part No.	Metric Size	Inch Size	No. Blades
READ8A	6.35 - 7.14	1/4 - 9/32	4
READ7A	7.14 - 7.94	9/32 - 5/16	4
READ6A	7.94 - 8.73	5/16 - 11/32	4
READ5A	8.73 - 9.52	11/32 - 3/8	5
READ4A	9.52 - 10.32	3/8 - 13/32	6
READ3A	10.32 - 11.11	13/32 - 7/16	6
READ2A	11.11 - 11.91	7/16 - 15/32	6
READA	11.91 - 13.49	15/32 - 17/32	6
READB	13.49 - 15.08	17/32 - 19/32	6
READC	15.08 - 16.67	19/32 - 21/32	6
READD	16.67 - 18.26	21/32 - 23/32	6
READE	18.26 - 19.84	23/32 - 25/32	6
READF	19.84 - 21.43	25/32 - 27/32	6
READG	21.43 - 23.81	27/32 - 15/16	6
READH	23.81 - 26.99	15/16 - 1-1/16	6
READI	26.99 - 30.16	1-1/16 - 1-3/16	6
READJ	30.16 - 34.13	1-3/16 - 1-11/32	6
READK	34.13 - 38.10	1-11/32 - 1-1/2	6
READL	38.10 - 46.04	1-1/2 - 1-13/16	6
READM	46.04 - 56.36	1-13/16 - 2-7/32	6
READN	56.36 - 69.85	2-7/32 - 2-3/4	6
READO	69.85 - 84.93	2-3/4 - 3-11/32	6



## CENTERING SQUARE

For locating turning centres on all square and round material  
Stainless steel  
Metric Calibrations

Part No.	RANGE
PCSS	100mm x 70mm
PCSM	150mm x 130mm
PCSL	200mm x 150mm



## TOOLMAKERS PARALLEL CLAMPS

Features hardened & tempered jaws  
Clamps equipped with spring screw clip  
Highly useful for holding small work together, when drilling, welding, assembling, etc  
End jaw is chamfered to clamp under a shoulder or in a recess

Part No.	Capacity x Jaw Size
TPC44 x 63	44mm x 63mm
TPC70 x 102	70mm x 102mm
TPC114 x 152	114mm x 152mm



## DEPTH GAUGE WITH PROTRACTORS

Manufactured from polished stainless steel  
Double graduation from 0 - 180° in opposite directions

The rectangular head model provides four convenient working edges  
Narrow 6" and 150mm rule  
Spring tension nut to secure the rule in the desired depth & angle

Part No.	DESCRIPTION
PRODGMERD	Round Head. 90mm x 150mm blade
PRODGMESQ	Rectangular 90mm x 50mm x 150mm blade



## UNIVERSAL BEVEL PROTRACTOR

Made of stainless steel  
With a magnifier for easy and clear reading  
Measuring surface hardened, ground and lapped ensures smooth movement  
Satin chrome finish, anti-rust and durable  
With fine adjustment  
Provided with 3 adjustments (150mm, 200mm, 300mm)

Part No.	Description
UBP300	Universal Bevel Protractor
UBPE300	Digital Universal Bevel Protractor

## DEGREE PROTRACTORS

Manufactured from polished stainless steel  
Double graduation from 0 - 180° in opposite directions  
The rectangular head model provides four convenient working edges  
Used to draw radial lines, setting bevels and transferring angles  
Knurled nut for firm setting of the blade

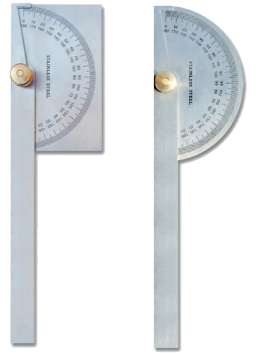

Part No.	DESCRIPTION
PRORD	Round Head. 90mm x 150mm blade
PROSQ	Rectangular 90mm x 50mm x 150mm blade

## PROTRACTORS ROUND OPEN HEAD STYLE

Locking type protractor with an open head  
Heavy duty, made from ground stainless steel  
Easy to read lettering, reads left to right  
0 - 180 degree

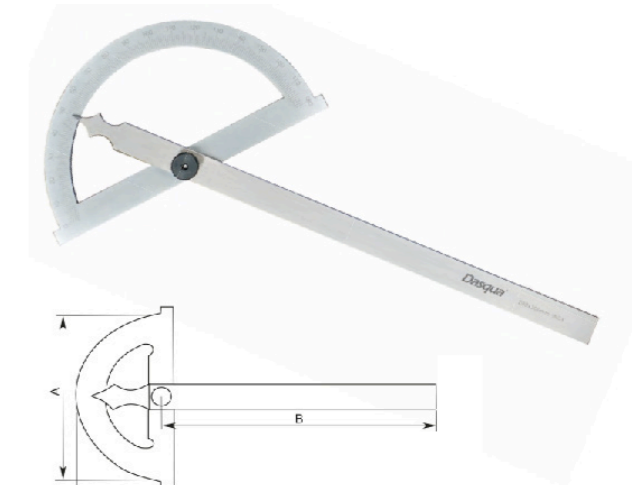

Part No.	A	B	DESCRIPTION
PRO	120	150	120mm Head x 150mm Rule
PROL	150	200	150mm Head x 200mm Rule
PROXL	200	300	200mm Head x 300mm Rule
PROXXL	300	500	300mm Head x 500mm Rule

## ANGULAR DEPTH GAUGE

Angular depth gauge can be used as a protractor for measuring angles 15°, 30° & 45° graduated left & right  
Rule is graduated metric one side, inches the other

Part No.	SIZE
DG150	150mm & 6 inch with 15, 30 & 45 degree
DG200	200mm & 8 inch with 15, 30 & 45 degree
DG300	300mm & 12 inch with 15, 30 & 45 degree

## ROUND SHEET METAL & WIRE GAUGE

Popular gauge for measuring steel wire, hot & cold rolled steel sheet  
Made from polished stainless steel  
Clear permanently etched graduations from 0 - 36

Part No.	DESCRIPTION
WGO-36	Wire Gauge 0 - 36

## DIAL THICKNESS GAUGE

For quick and easy measurements of small parts and thicknesses.  
Often used to measure thickness of paper, leather, rubber, fabric, metal plate, glass and plastic plate etc.  
0.1mm Graduation

Part No.	RANGE
DTG010	0-10mm
DTG020	0-20mm

## CENTRE GAUGES

Very useful gauge used in grinding and setting screw cutting tools. Clearly etched scale for finding number of threads per inch through graduations in 14th, 20ths, 24ths, & 32nds of an inch. Also features a table of double depth of thread for determining size of tap drills. Made of tempered stainless steel

Part No.	Thread profiles
CGM	Metric threads 60° mm scale
CGUN	American threads 60° inch scale
CGW	BSW threads 55° scale

## DRILL GAUGES

Hole sizes and decimal equivalents permanently etched

Part No.	Description
DGM	1 - 13mm x 0.1mm increments
DGIMP	1/16 - 1/2 x 1/32 increments
DGL	Letter Drills A - Z
DGN	Number Drills 60 - 80



## UNIVERSAL SCREW CUTTING GAUGE

Used for gauging thread profiles 47.5° BA, 14.5° ACME, 60° American & Metric, 55° BSW & BSF  
Stainless Steel with clearly etched graduation

Part No.	Thread profiles
UNSCG	BA - ACME - Metric - BSW - UNC - UNF



## SCREW PITCH GAUGES

Useful gauges to quickly determine the pitch of various threads  
All leaves are clearly marked with the size  
Features a locking device at both ends to securely lock the leaves  
Made of high quality polished tool steel

Part No.	Description
SPGM	Metric 24 blades 0.25 - 6mm
SPGME	Metric / BSW 52 blades 0.25 - 6mm & 4 - 62
SPGUN	UNC / UNF 60° 31 blades 4 - 42
SPGUNL	UNC / UNF 60° 31 blades 4 - 84
SPGW	BSW 55° 28 blades 4 - 62 G
SPGBSP	BSP 6 blades 8 - 28
SPGMUN	Metric / Unified 52 blades 0.25 - 6mm 4 - 62

## RADIUS GAUGES

Handy device for checking radii of tools and dies easier & faster - measures both convex & concave radii

Part No.	Description
RG1-7	1 - 7mm 34 leaves
RG7.5-15	7.5 - 15mm 32 leaves
RG15-25	15.5 - 25mm 30 leaves
RG1/32-1/4	1/32 - 1/4 by 1/64 30 leaves
RG17/64-1/2	17/64 - 1/2 by 1/64 32 leaves



## TAPER GAUGE

Handy gauge for measuring cylindrical bores, bearing work & gauging slots  
Made from polished stainless steel  
Clearly etched graduations for metric on one side and inch the other



Part No.	Description
TGME	1 - 16mm & 1/32 - 5/8 inch

## WING COMPASS

Square leg, heavy duty, polished steel, hardened & ground point.



Part No.	Size
WC150	150mm
WC200	200mm
WC250	250mm
WC300	300mm
WC500	500mm
WC600	600mm
WC800	800mm

Part No.	Size
JC100	100mm
JC150	150mm
JC200	200mm
JC250	250mm
JC300	300mm

## JENNY CALIPERS

### HERMAPHRODITE CALIPER

Used in layout works for locating and testing centres. Adjustable point.



## FIRM JOINT DIVIDERS

Firm joint to adjust tension as desired. Legs machined to rigid length and balance



Part No.	Size
FD150	150mm
FD200	200mm
FD300	300mm
FD450	450mm
FD600	600mm

Part No.	Size
FIC150	150mm
FIC200	200mm
FIC250	250mm
FIC300	300mm
FIC450	450mm
FIC600	600mm
FIC900	900mm

## FIRM JOINT INSIDE CALIPERS

Firm joint to adjust tension as desired. Legs machined to rigid length and balance



Part No.	Size
FOC150	150mm
FOC200	200mm
FOC250	250mm
FOC300	300mm
FOC450	450mm
FOC600	600mm
FOC900	900mm
FOC1050	1050mm

## FIRM JOINT OUTSIDE CALIPERS

Firm joint to adjust tension as desired. Legs machined to rigid length and balance





Inside Calipers

Outside Calipers



Spring Dividers  
Solid Nut & Washer



### SPRING DIVIDERS

Flat leg, heat treated points, polished steel  
solid nut & washer, hardened & tempered spring

Part No.	Size
SD075	75mm
SD100	100mm
SD150	150mm
SD200	200mm
SD250	250mm
SD300	300mm
SD450	450mm
SD600	600mm
SD900	900mm

### OUTSIDE CALIPERS

Flat leg, heat treated points, polished steel  
solid nut & washer, hardened & tempered spring

Part No.	Size
OC075	75mm
OC100	100mm
OC150	150mm
OC200	200mm
OC250	250mm
OC300	300mm
OC450	450mm
OC600	600mm
OC900	900mm

### INSIDE CALIPERS

Flat leg, heat treated points, polished steel  
solid nut & washer, hardened & tempered spring

Part No.	Size
IC075	75mm
IC100	100mm
IC150	150mm
IC200	200mm
IC250	250mm
IC300	300mm
IC450	450mm
IC600	600mm
IC900	900mm

### ENGINEERS PRECISION SQUARES

#### INTERNAL & EXTERNAL SQUARENESS TO DIN 875 OR BS939

#### GRADE B

Made of the finest quality ground steel  
Blade is hardened & ground for straightness and parallelism  
For setting up and checking jobs where extreme accuracy is required

Part No.	Blade x Stock Length
ESQ025	25mm x 38mm
ESQ050	50mm x 50mm
ESQ075	75mm x 63mm
ESQ100	100mm x 75mm
ESQ150	150mm x 100mm
ESQ200	200mm x 127mm
ESQ225	225mm x 150mm
ESQ250	250mm x 150mm
ESQ300	300mm x 200mm
ESQ450	450mm x 254mm
ESQ600	600mm x 330mm
ESQ915	915mm x 445mm



LARGE SCREEN READOUT  
15MM CHARACTER HEIGHT

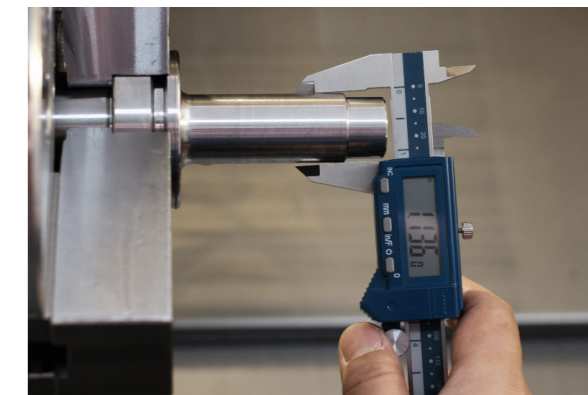

### DIGITAL CALIPERS IP54 SPLASH PROOF

Advanced Design  
IP54 Protection against water, dust, oil or any other liquid  
Hardened, ground and lapped measuring surfaces  
Zero setting at any position, plus data hold

Strictly made in accordance with DIN862  
Silky Smooth Movement throughout  
Millimetres, Decimal, & Fraction

Part No.	Old Part No	Description	Range	Reading
CE150LS54	111-101FR	Digital Caliper IP54 Splashproof Large Screen Triple Read Scale	150mm / 6"	0.01mm / 0.0005"
CE200LS54	111-102FR	Digital Caliper IP54 Splashproof Large Screen Triple Read Scale	200mm / 8"	0.01mm / 0.0005"
CE300LS54	111-103FR	Digital Caliper IP54 Splashproof Large Screen Triple Read Scale	300mm / 12"	0.01mm / 0.0005"

### DIGITAL CALIPERS IP67 COOLANT PROOF

Advanced Design  
Strictly made in accordance with DIN862  
IP67 Protection against water, dust, oil or any other

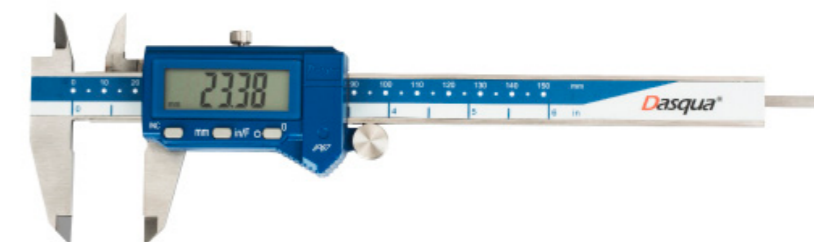

15MM CHARACTER HEIGHT

Part No.	Description	Range	Reading
CE150CP67	Digital Caliper IP67 Coolant Proof Large Screen	150mm / 6"	0.01mm / 0.0005"
CE200CP67	Digital Caliper IP67 Coolant Proo Large Screen	200mm / 8"	0.01mm / 0.0005"
CE300CP67	Digital Caliper IP67 Coolant Proof Large Screen	300mm / 12"	0.01mm / 0.0005"

### LARGE SCREEN DIGITAL CALIPERS

With long jaws  
Strictly made in accordance with DIN862  
With fine adjustment  
With hold function  
Hardened stainless steel construction for long life  
Metric / inch fraction conversion

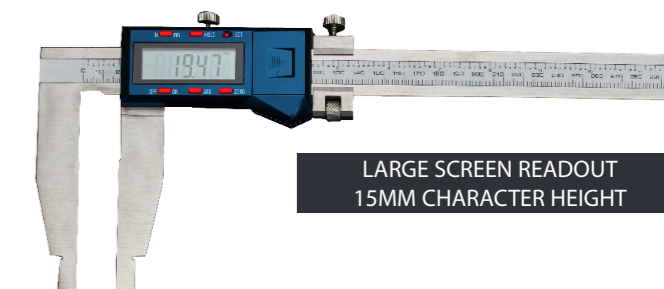

LARGE SCREEN READOUT  
15MM CHARACTER HEIGHT

CE300LJ	Digital Caliper large LCD readout 90mm jaws	300mm / 12"	0.01mm / 0.0005"
CE500	Digital Caliper large LCD readout 100mm jaws	500mm / 20"	0.01mm / 0.0005"
CE600	Digital Caliper large LCD readout 100mm jaws	600mm / 24"	0.01mm / 0.0005"
CE1000	Digital Caliper large LCD readout 200mm jaws	1m / 40 inch	0.01mm / 0.0005"

## VERNIER CALIPERS WITH WIRELESS CONNECTIVITY

Advanced Design  
Wireless capability built in  
Strictly made in accordance with DIN862  
IP54 Protection against water, dust, oil or any other liquid  
Silky Smooth Movement throughout  
Hardened, ground and lapped measuring surfaces  
**Larger sizes available on request**

Part No.	Description	Range	Reading
CE150BT54	Digital Caliper Wireless IP54 Triple Read Scale	150mm / 6"	0.01mm / 0.0005"

## POLYAMIDE VERNIER CALIPERS

**SCALE:** 5 Digit display with 7.5mm numeral height for easy readings.

**MATERIAL:** Made from Non-Metallic high tech material with 50% fibre glass content.

**READING:** 0.01mm as well as 0.0005 inch

**STANDARD:** CE Compliant

**APPLICATION:** For outside, inside and depth measurements

### Additional Information:

- Switches off automatically after 5 minutes of non-use.
- Zero setting possible in every position for quick comparison measurements.

Part No.	Description	Range	Reading
CEP150ME	Digital Caliper Polyamide 150mm CE Compliant	150mm / 6"	0.01mm / 0.0005"
CVP150ME	Vernier Caliper Polyamide 150mm CE Compliant	150mm / 6"	0.1mm / 0.015"

## VERNIER CALIPERS



STANDARD

STANDARD AND FINE ADJUSTMENT AVAILABLE FOR MOST SIZES

Part No.	Description	Range	Reading
CV150ME	Vernier Caliper with locking screw	150mm / 6"	0.02mm / 0.001"
CV150MEFA	Vernier Caliper with fine adjustment	150mm / 6"	0.02mm / 0.001"
CV200MEFA	Vernier Caliper with fine adjustment	200mm / 8"	0.02mm / 0.001"
CV300MEFA	Vernier Caliper with fine adjustment	300mm / 12"	0.02mm / 0.001"
CV600MEFA	Vernier Caliper fine adjustment 90mm jaws	600mm / 24"	0.02mm / 0.001"
CV1MMEFA	Vernier Caliper fine adjustment 125mm jaws	1m / 40"	0.02mm / 0.001"
CV1.5MEFA	Vernier Caliper fine adjustment 125mm jaws	1.5m / 60"	0.02mm / 0.001"
CV2MEFA	Vernier Caliper fine adjustment 200mm jaws	2m / 80"	0.02mm / 0.001"

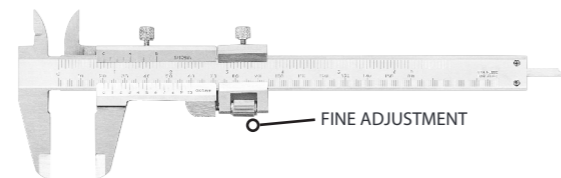

4 usages for measuring outside diameter, inside diameter, step and depth.

Strictly made in accordance with DIN862.

Made with Stainless Steel.

Distinct lines and figures etched against satin chrome finish.

With locking screen for stable reading.

## GEAR TOOTH VERNIER CALIPERS

Vertical scale measures the depth of the teeth from the top of the pitch line

Horizontal scale is used to measure the Chordal Thickness of the gear tooth

The gear does not have to be removed from the machine

Range 1 - 26 Graduations 0.02mm Accuracy ± 0.02mm

Part No.
CVGT

## DIAL CALIPERS

Part No.	Description	Range	Reading
CDL150	Dial Caliper	150mm	0.02mm
CDL200	Dial Caliper	200mm	0.02mm
CDL300	Dial Caliper	300mm	0.02mm
CDL6	Dial Caliper	6 inch	0.001"

## PRECISION MACHINE LEVELS

Used to measure straightness and parallelism of the guideways of various kinds of machine tools and other equipment, and to inspect the horizontal or perpendicular position after the installation of equipment.

Part No.	Size	Accuracy
PL100x0.02	100mm	0.02mm
PL150x0.02	150mm	0.02mm
PL200x0.02	200mm	0.02mm
PL200x0.05	200mm	0.05mm
PL250x0.02	250mm	0.02mm
PL300x0.02	300mm	0.02mm

## PRECISION FRAME LEVELS

Mainly used to inspect guide way straightness of various kinds of machine tools and other equipment, and to inspect the horizontal or perpendicular position after the installation of equipment. The measuring surfaces are "V" shaped so that the levels can be used on cylinders.

Part No.	Size	Accuracy
PLSQ150x0.05	150mm	0.05mm
PLSQ200x0.02	200mm	0.02mm
PLSQ200x0.05	200mm	0.05mm

## GAUGE BLOCK SETS NEW

Part No.	Description
GBM103-0	GRADE 0 - 103 Pce metric set
GBM103-1	GRADE 1 - 103 Pce metric set
GBM112-0	GRADE 0 - 112 Pce metric set
GBM112-1	GRADE 1 - 112 Pce metric set
GBM32-0	GRADE 0 - 32 Pce metric set
GBM32-1	GRADE 1 - 32 Pce metric set
GBM47-0	GRADE 0 - 47 Pce metric set
GBM47-1	GRADE 1 - 47 Pce metric set
GBM87-0	GRADE 0 - 87 Pce metric set
GBM87-1	GRADE 1 - 87 Pce metric set



## THREAD PLUG GAUGES

- A thread limit plug gauge is a combination of go plug gauge and no-go plug gauge. The scrap side of the thread plug gauge is marked with a red ring.
- The go end of the thread plug gauge must screw into the thread cut into a part by hand (without using excessive force). If unable to do so, the thread does not meet the requested standards (=scrap).
- The scrap side of the thread plug gauge must not be able to be manually turned more than two turns into the cut thread (without using excessive force). If it can be screwed in more, the thread does not meet the requested standards (=scrap).
- The reference temperature for parts and gauges is 20° Celsius. A very wide range is available on request, including Thread Ring Gauges.



7 pce set comes with Thread Pce M3, M4, M5, M6, M8, M10, 12

NEW

Part No.	Description
TPGM01420	M14 X 2.0
TPGM01602	M16 X 2.0
TPGS03012	7 PCE SET



### THREE POINTS INSIDE MICROMETER SET

- Strictly made in accordance with DIN863
- Carbide measuring faces
- Satin chrome-plated scales and operating parts
- Self aligning and self centring
- Ratchet stop to provide uniform measuring pressure for highest possible reading accuracy
- Non-removable anvils
- Includes extension ring gauge, supplied with extension



Part No.	Range (mm)	Points (mm)	Resolution (mm)	Extension (mm)
MICIN0612	6-12	6-8, 8-10, 10-12	0.001	50
MICIN1220	12-20	12-16, 16-20	0.005	100
MICIN2050	20-50	20-25, 25-30, 30-40, 40-50	0.005	150
MICIN50100	50-100	50-63, 62-75, 75-88, 87-100	0.005	150

### INSIDE MICROMETER - CALIPER TYPE

Hardened and Ground Spindle Threads and Measuring Face

Part No.	Range	Reading
MICIN5-30	5 - 30mm	0.01mm
MICIN25-50	25 - 50mm	0.01mm
MICIN50-75	50 - 75mm	0.01mm
MICIN75-100	75 - 100mm	0.01mm

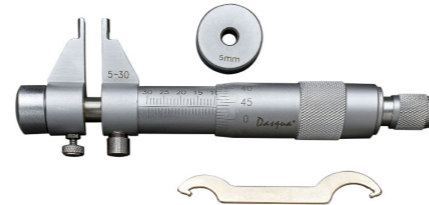

### INSIDE MICROMETER - EXTENSION ROD TYPE

Part No.	Range	Reading
MICIN50-250	50 - 250mm	0.01mm
MICIN25-50	25 - 50mm	0.001 inch



**NEW**

### DIAL BORE GAUGES

Part No.	Range	Reading
BG35-160	35-160	0.01

- Large measuring range from 35mm to 160mm
- So cost effective that can reach the range of 2 or 3 dial bore gauges
- Carbide Tipped and ceramic contact points optional for customers' desires
- Strictly made in accordance with DIN878



**NEW**

### PIN GAUGE SETS

- Strictly Made in accordance with DIN2269
- Perfect for measuring hole diameter, distance between holes, hole location, slot standards of setting measuring equipment
- Made of hardened steel, heat treatment, abrasion resistant, hardness 60-63HRC, precision ground for long service life

Part No.	Range	PCE	Standard
PGC0110	0-10MM	91 PCEs	DIN2269



**NEW**



\*MICD AVAILABLE UP TO 100MM  
IMPERIAL SIZES AVAILABLE UPON REQUEST UP TO 4"

\*MIC LISTED BELOW

### OUTSIDE MICROMETERS BOXED SETS

Part No.	Description
MIC0-75	Micrometer 3 piece set
<b>0 - 75mm range x 0.01mm</b>	
MIC0-150	Micrometer 6 piece set
<b>0 - 150mm range x 0.01mm</b>	
MIC0-300	Micrometer 12 piece set
<b>0 - 300mm range x 0.01mm</b>	
MIC0-6	Micrometer 6 piece set
<b>0 - 6 inch range x 0.001"</b>	



### OUTSIDE MICROMETERS

Part No.	Range	Reading
MIC0-25	0 - 25mm	0.01mm
MIC25-50	25 - 50mm	0.01mm
<b>NEW</b> MICD025	0 - 25mm	0.01mm
MIC50-75	50 - 75mm	0.01mm
MIC75-100	75 - 100mm	0.01mm
MIC100-125	100 - 125mm	0.01mm
MIC125-150	125 - 150mm	0.01mm
MIC150-175	150 - 175mm	0.01mm
MIC175-200	175 - 200mm	0.01mm
MIC200-225	200 - 225mm	0.01mm
MIC225-250	225 - 250mm	0.01mm
MIC250-275	250 - 275mm	0.01mm
MIC275-300	275 - 300mm	0.01mm
MIC300-400	300 - 400mm	0.01mm
MIC400-500	400 - 500mm	0.01mm
MIC500-600	500 - 600mm	0.01mm
MIC600-700	600 - 700mm	0.01mm
MIC700-800	700 - 800mm	0.01mm
MIC800-900	800 - 900mm	0.01mm
MIC900-1000	900 - 1000mm	0.01mm
MIC0-1	0 - 1"	0.001"
MIC1-2	1 - 2"	0.001"
MIC2-3	2 - 3"	0.001"
MIC3-4	3 - 4"	0.001"
MIC4-5	4 - 5"	0.001"
MIC5-6	5 - 6"	0.001"
MIC6-7	6 - 7"	0.001"
MIC7-8	7 - 8"	0.001"
MIC8-9	8 - 9"	0.001"
MIC9-10	9 - 10"	0.001"
MIC10-11	10 - 11"	0.001"
MIC11-12	11 - 12"	0.001"

Large Micrometers contain Interchangeable Anvils

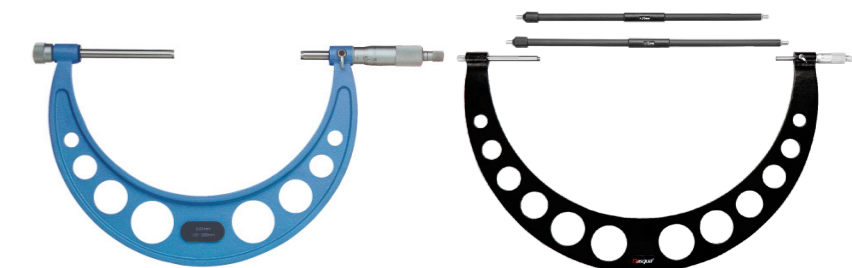

## DISK BRAKE MICROMETER

Part No.	Range	Reading
MICDB	7.6 - 33mm	0.01mm

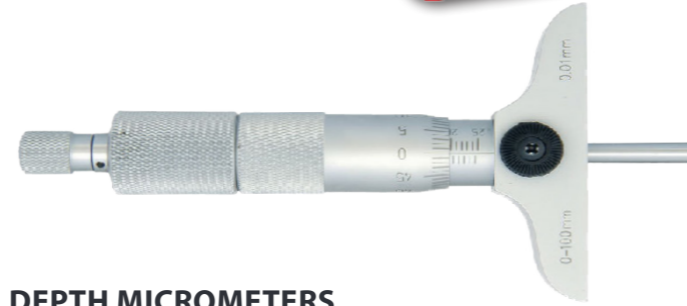

## DEPTH MICROMETERS

Part No.	Range	Reading
MICD1	0 - 1 inch	0.001"
MICD6	0 - 6 inch	0.001"
MICD25	0 - 25mm	0.01mm
MICD100	0 - 100mm	0.01mm

## ELECTRONIC DIGITAL OUTSIDE MICROMETERS

Large display  
Data Hold & ABS.  
Carbide Tipped Anvils  
Ratchet stop handle

Power On / Off.  
Metric reading 0.001mm and Inch reading 0.00005"  
Hardened & Ground Measuring Spindle

Part No.	Range
MICE0-25	0 - 25mm & 0 - 1 inch
MICE25-50	25 - 50mm & 1 - 2 inch
MICE50-75	50 - 75mm & 2 - 3 inch
MICE75-100	75 - 100mm & 3 - 4 inch
MICE100-125	100 - 125mm & 4 - 5 inch
MICE125-150	125 - 150mm & 5 - 6 inch
MICE150-175	150 - 175mm & 6 - 7 inch
MICE175-200	175 - 200mm & 7 - 8 inch



## IP65 WATER PROOF ELECTRONIC DIGITAL OUTSIDE MICROMETERS

Large display  
Data Hold & ABS.  
Carbide Tipped Anvils

Power On / Off.  
Metric reading 0.001mm and Inch reading 0.00005"  
Hardened & Ground Measuring Spindle

Part No.	Range
MICE0025IP65	0 - 25mm & 0 - 1 inch
MICE2550IP65	25 - 50mm & 1 - 2 inch
MICE5075IP65	50 - 75mm & 2 - 3 inch
MICE75100IP65	75 - 100mm & 3 - 4 inch



## ELECTRONIC DIGITAL OUTSIDE MICROMETER WITH WIRELESS CONNECTIVITY

Wireless capability built in  
Large display  
Data Hold & ABS.  
Carbide Tipped Anvils  
Ratchet stop handle

Quick Measuring Function  
Power On / Off.  
Metric reading 0.001mm and Inch reading 0.00005"  
Hardened & Ground Measuring Spindle



Larger sizes can be ordered on request

Part No.	Range
MICE0025BT65	0 - 25mm & 0 - 1 inch



## VERNIER HEIGHT GAUGES

Fine adjustment  
Magnifying glass for quick and easy reading

Part No.	Description	Range	Reading
HGV300FAME	Vernier Height Gauge	300mm	0.02mm
HGV500FAME	Vernier Height Gauge	500mm	0.02mm
HGV1000FAME	Vernier Height Gauge	1000mm	0.02mm

## DIGITAL HEIGHT GAUGES

Part No.	Description	Range	Reading
HGE300ME	Digital Height Gauge	300mm/12"	0.01mm/0.0005"
HGE500ME	Digital Height Gauge	500mm/20"	0.01mm/0.0005"
HGE1000ME	Digital Height Gauge	1000mm/40"	0.01mm/0.0005"



## VERNIER DEPTH GAUGES

Part No.	Description	Range	Reading
DGV250	Vernier Depth Gauge	250mm	0.05mm
DGV300	Vernier Depth Gauge	300mm	0.02mm
DGV500	Vernier Depth Gauge	500mm	0.02mm

## DIGITAL DEPTH GAUGES

Part No.	Description	Range	Reading
DGE150	Digital Depth Gauge	150mm	0.01mm / 0.0005"
DGE300	Digital Depth Gauge	300mm	0.01mm / 0.0005"
DGE500	Digital Depth Gauge	500mm	0.01mm / 0.0005"



NEW

## HYDRAULIC MAGNETIC BASE

Part No.	Holding Power	Base	Bottom Arm	Top Arm	Dia. Of Clam Hole
MBH7412	80kg	60 x 50 x 55	120mm	116mm	6.0 x 8.0 x dovetail

- Mechanical central locking of all joints
- Special structure ensures high pressure
- Oil hydraulics protected against oil leakage by double seals
- Powerful permanent magnet- Smooth and easy on/off switch
- Joined arms rotate 360 degrees on the dial indicator holder and can be twisted 180 degrees



NEW

## MINI MAGNETIC HOLDER

Part No.	Holding Power	Base	Dia. Of Clam Hole
MBD0005	20kg	73 x 37 x 12	8.0
MBD0010	20kg	73 x 37 x 26	8.0

- Smaller shape ensures easy and fast fixing to the machine and vices
- light metal with laminated permanent magnets
- Low height enables fast, safe and wasy mount on machines and jigs
- Black enamel finish





Long Measuring Range

### DIAL INDICATORS

Part No.	RANGE	Reading	Diameter
DIM10	0 - 10mm	0.01mm	58mm
DIM30	0 - 30mm	0.01mm	58mm
DIM50	0 - 50mm	0.01mm	58mm
DIM80	0 - 80mm	0.01mm	58mm
DIM100	0 - 100mm	0.01mm	58mm
DII1/2	0 - 1/2"	0.001"	58mm
DII1	0 - 1"	0.001"	58mm
DII2	0 - 2"	0.001"	58mm



### DIAL TEST INDICATORS

Part No.	RANGE	Reading	Diameter
TIM008	0 - 0.8mm	0.01mm	30mm
TII003	0 - 0.03 inch	0.0005"	30mm



### DIGITAL INDICATORS

Part No.	RANGE	Reading
DIE13	12.7mm - 1/2"	0.01mm - 0.0005"

### DIGITAL INDICATORS WITH WIRELESS CONNECTIVITY

Larger sizes can be ordered on request



Part No.	RANGE	Reading
DIE127BT	12.7mm - 1/2"	0.01mm - 0.0005"

### UNIVERSAL SURFACE MARKING GAUGE

Basic tool for machinists and toolmakers for accurately scribing lines, transferring measurements and probing during inspection work.

Base 82 x 63 x 25mm  
Spindle diameter 9.5mm



Part No.	Size
USG300	300mm spindle

### SLIDING T-BEVEL

Stainless Steel blade with aluminium handle

Adjustable gauge for setting & transferring angles. The blade pivots and can be locked at any angle by loosening or tightening the thumbscrew.

Can be used to duplicate an existing angle or set to a desired angle.



Part No.	Size
STB250SS	250mm blade

### TELESCOPIC GAUGES

For quick inside measurement & determination of inside diameters  
Spring loaded plunger that expands in the bore or groove

Part No.	Range
TGSET8-150	8mm through 152mm
TGSET300LR	8mm through 152mm with 300mm Long Reach

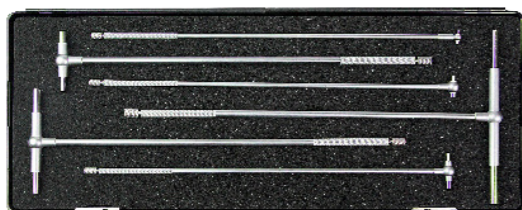

### POT MAGNETS

General purpose magnet - magnetic fasteners, displays, holding maps etc

Supplied with plated keepers

Part No.	Size	Approximate Pull
MPA16X17	16 x 17mm	2.65 Kg
MPB19X22	19 x 22mm	4.00 Kg
MPC25X27	25 x 27mm	5.00 Kg
MPD30X35	30 x 35mm	10.5 Kg



### MAGNIFYING GLASS - EYE LOUPE

Lens made of clear ground & polished glass

Body made from black polished plastic

Hands free magnification

Part No.	Magnification	Focal Length
MG10	10 X	25mm



### ADHESIVE BACKED MEASURING TAPES

Use as a customized measure for workbenches, saw tables, machinery, desks countertops, poles, walls, columns etc

Can be cut to desired length

Part No.	Description
ABT2M	2 metre reads left to right
ABT5M	5 metre reads left to right
ABT2MRL	2 metre reads right to left
ABT5MRL	5 metre reads right to left

### MARKING GAUGE ROUND TYPE

Vernier Scale

Thumb screw for easy adjustment

FAME model features Fine Adjustment

Part No.	Range	Reading	Fine Adjustment
MG300	300mm	0.1mm	No
MG500	500mm	0.1mm	Yes
MG300S	Replacement Scriber	-	-
MG300SCREW	Replacement Screw	-	-

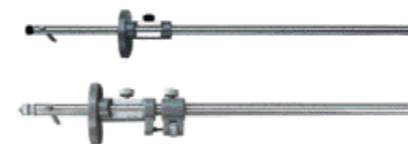

### TRAMMELS

Trammels & Trammel Heads

Used to draw circles and measure sizeable distances with the accuracy of a divider. Also for layout, marking templates. Needle point legs and one trammel can hold a pencil.

Part No.	Description
TRHEADS	Trammel Head Set 2 PCE
TR500	Trammel Set with Fine Adj up to 500mm

## FEELER STRIP

METRIC 12.7 x 300mm Long

IMPERIAL 1/2 x 12 Inch Long

Part No.	Thickness	Part No.	Thickness
FSM0.03	0.03mm	FSM1.70	1.70mm
FSM0.04	0.04mm	FSM1.80	1.80mm
FSM0.05	0.05 mm	FSM1.90	1.90mm
FSM0.06	0.06 mm	FSM2.00	2.00mm
FSM0.07	0.07 mm	FSIO.001	0.001 inch
FSM0.08	0.08 mm	FSIO.0015	0.0015 inch
FSM0.09	0.09 mm	FSIO.002	0.002 inch
FSM0.10	0.10mm	FSIO.0025	0.0025 inch
FSM0.11	0.11mm	FSIO.003	0.003 inch
FSM0.12	0.12mm	FSIO.004	0.004 inch
FSM0.13	0.13mm	FSIO.005	0.005 inch
FSM0.14	0.14mm	FSIO.006	0.006 inch
FSM0.15	0.15mm	FSIO.007	0.007 inch
FSM0.16	0.16mm	FSIO.008	0.008 inch
FSM0.17	0.17mm	FSIO.009	0.009 inch
FSM0.18	0.18mm	FSIO.010	0.010 inch
FSM0.19	0.19mm	FSIO.011	0.011 inch
FSM0.20	0.20mm	FSIO.012	0.012 inch
FSM0.25	0.25mm	FSIO.013	0.013 inch
FSM0.30	0.30mm	FSIO.014	0.014 inch
FSM0.35	0.35mm	FSIO.015	0.015 inch
FSM0.40	0.40mm	FSIO.016	0.016 inch
FSM0.45	0.45mm	FSIO.017	0.017 inch
FSM0.50	0.50mm	FSIO.018	0.018 inch
FSM0.55	0.55mm	FSIO.019	0.019 inch
FSM0.60	0.60mm	FSIO.020	0.020 inch
FSM0.65	0.65mm	FSIO.021	0.021 inch
FSM0.70	0.70mm	FSIO.022	0.022 inch
FSM0.75	0.75mm	FSIO.023	0.023 inch
FSM0.80	0.80mm	FSIO.024	0.024 inch
FSM0.85	0.85mm	FSIO.025	0.025 inch
FSM0.90	0.90mm	FSIO.026	0.026 inch
FSM0.95	0.95mm	FSIO.027	0.027 inch
FSM1.00	1.00mm	FSIO.028	0.028 inch
FSM1.10	1.10mm	FSIO.029	0.029 inch
FSM1.20	1.20mm	FSIO.030	0.030 inch
FSM1.30	1.30mm	FSIO.032	0.032 inch
FSM1.40	1.40mm	FSIO.035	0.035 inch
FSM1.50	1.50mm	FSIO.040	0.040 inch
FSM1.60	1.60mm		



### SETS

FSSETMM300MM
20 piece 0.05 - 1mm
300mm length
FSSETMM150MM
20 piece 0.05 - 1mm in 0.05
increments
150mm length
FSSETMM100MM
10 piece 0.05 - 80mm
100mm length
100mm length



Single Replaceable Point

Replaceable Carbide Tip

Regular & Chisel Point

## ENGINEERS SCRIBERS

Part No.	Description
SC190	L Shaped. Double Ended. Knurled Body. 190mm length
SC225	L Shaped. Double Ended. Knurled Body. 225mm length
SCTCT	Fixed Carbide Tip. Chrome Plated Handle. Pocket Clip. 150mm length
SCTCWRT	Replaceable Carbide Tip. Magnetic End. Knurled Body. Pocket Clip. 150mm length
SCTCWRTTIP	- Replacement Carbide Tip for SCTCWRT
SCMACH	Single Replaceable Point. Knurled Body. 125mm length
SCCH	Regular Point & Chisel Point Knurled Body. 165mm length



L Shape

Fixed Carbide Tip



## PARTING TOOL HOLDERS HSS - STRAIGHT

- Heat treated hardened body
- Machined to precise tolerances
- Support the blade over a wide area, reducing blade breakage
- Supplied with one wrench

Part No.	Blade Size	Shank Size
LPTH5/16	5/16"	8 x 14 x 90mm
LPTH1/2	1/2"	8 x 19 x 114mm
LPTH5/8	5/8"	9.5 X 22 X 127mm
LPTH3/4	3/4"	13 x 28 x 152mm
LPTH7/8	7/8"	16 x 35 x 178mm
LPTH1	1 inch	19 x 41 x 203mm



Blades sold separately

## PARTING TOOL HOLDERS CLAMP TYPE

- Tool blocks with rigid construction for 100% clamping power
- Hardened and tempered body
- Can be used on front or rear tool posts

Part No.	Shank Size	Body Size	Blade Size
COTB1/2	1/2"	55 x 30.5 x 28mm	3/4"
COTB5/8	5/8"	90 x 38 x 32mm	1 inch
COTB3/4	3/4"	90 x 38 x 36mm	1 inch



Blades sold separately

## LATHE PARTING TOOL BLADES

Part No.	Material	Blade Size
LPT5/16	HSS M-2	5/16 x 1/16 x 3-1/2
LPT1/2	HSS M-2	1/2 x 3/32 x 4
LPT5/8	HSS M-2	5/8 x 3/32 x 5
LPT3/4	HSS M-2	3/4 x 1/8 x 6
LPT7/8	HSS M-2	7/8 x 1/8 x 6
LPT1	HSS M-2	1 x 3/16 x 6



- Available in HSS M-2 & 5% Cobalt
- Fit most common tool holders
- Hardened & Ground
- Trapezoidal section to fit standard tool holders

## FLY CUTTER HOLDERS

- Counterbalanced to get smoother finishes
- Machines up to 150mm wide surface with standard tool bit

- Round shank 1/2" & 3/4"

Part No.	Bit Size	Head Diameter	Shank
FC3/16	3/16"	19mm - 3/4"	1/2"
FC1/4	1/4"	28mm - 1-1/8"	1/2"
FC5/16	5/16"	38mm - 1-1/2"	1/2"
FCSET1/2	1/2" shank set of 3 includes above 3 sizes		
FC1.5-3/4	5/16"	38mm - 1-1/2"	3/4"
FC2.5-3/4	5/16"	64mm - 2-1/2"	3/4"
FCSET3/4	3/4" shank set of 3 includes (38mm, 50.8mm, 63.5mm)		



Bits sold separately



## TURNING TOOL HOLDERS



- Accurately machined from special steel
- Available in straight, left & right hand shanks
- Supplied with Wrench / Key

Holder size dimensions are :  
Length x Height x Width

Part No.	Bit Size	Holder Size	Shank
LTH1/8	1/8	115 x 12.7 x 8mm	Straight
LTH3/16	3/16	115 x 19 x 8mm	Straight
LTH1/4	1/4	125 x 22.5 x 10mm	Straight
LTH5/16	5/16	152 x 28 x 13mm	Straight
LTH3/8	3/8	178 x 35 x 16	Straight
LTH1/2	1/2	228 x 44 x 22mm	Straight
LTH5/8	5/8	280 x 50 x 25mm	Straight
LTH3/4	3/4	330 x 57 x 32mm	Straight
LTH3/16R	3/16	115 x 19 x 8mm	Right Hand
LTH1/4R	1/4	125 x 22.5 x 10mm	Right Hand
LTH5/16R	5/16	152 x 28 x 13mm	Right Hand
LTH3/8R	3/8	178 x 35 x 16	Right Hand
LTH1/2R	1/2	228 x 44 x 22mm	Right Hand
LTH5/8R	5/8	280 x 50 x 25mm	Right Hand
LTH3/4R	3/4	330 x 57 x 32mm	Right Hand
LTH3/16L	3/16	115 x 19 x 8mm	Left Hand
LTH1/4L	1/4	125 x 22.5 x 10mm	Left Hand
LTH5/16L	5/16	152 x 28 x 13mm	Left Hand
LTH3/8L	3/8	178 x 35 x 16	Left Hand
LTH1/2L	1/2	228 x 44 x 22mm	Left Hand
LTH5/8L	5/8	280 x 50 x 25mm	Left Hand
LTH3/4L	3/4	330 x 57 x 32mm	Left Hand

## DOUBLE ENDED BORING BARS WITH HOLDERS

Part No.	Bar Size	Holder Size	Square Bit
LBB1/8HSS	3/8 x 4-1/2	1/2 x 2-1/4	1/8"
LBB3/16HSS	7/16 x 5-1/4	5/8 x 2-1/2	3/16"
LBB1/4HSS	9/16 x 6-3/4	5/8 x 3	1/4"
LBB5/16HSS	3/4 x 9-1/4	7/8 x 3-3/4	5/16"
LBB3/8HSS	7/8 x 11-1/2	1-1/4 x 4-1/2	3/8"
LBB1/2HSS	1-3/16 x 13-3/4	1-5/8 x 5	1/2"

- Double ended boring bars & holder comes complete with screws & hex keys
- Boring Bars have one end 45° and the other 90°
- Made from tool steel with black finish



## SLOTTED ANGLE PLATES

Made of high quality seasoned castings

Accurately machined 90 degrees square

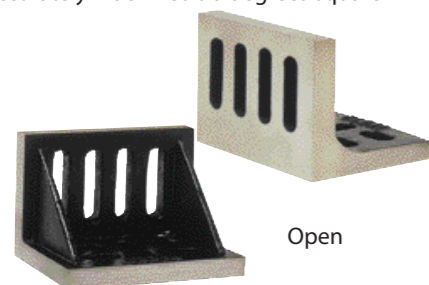

Open

Webbed

Part No.	Length	First	Second	Style
AP075	75mm	63mm	50mm	Slotted & Webbed
AP112	115mm	90mm	75mm	Slotted & Webbed
AP150	150mm	125mm	115mm	Slotted & Open
AP200	200mm	150mm	125mm	Slotted & Webbed
AP250	250mm	200mm	150mm	Slotted & Webbed
AP300	300mm	225mm	200mm	Slotted & Open
AP300W	300mm	225mm	200mm	Slotted & Webbed



## COMBINATION SQUARE CAST IRON

Sturdy high quality cast iron  
Combination Square

- Metric & Imperial measurements
- Spirit Level on square & protractor
- Engraved graduations on both the rule & protractor
- Rule has a Satin Chrome Finish
- Supplied in a Sturdy Storage Case



NEW

Part No.	Description
COMBSETCI	Combination Set Cast Iron 300mm / 12 inch Rule
COMBSQ	Combination Square for Cast Iron Set
COMBSACE	Combination Set Centre Finder Piece Only
COMBSAPRO	Combination Set Cast Iron Protractor Head Only
COMBR300ME	Ruler to Suit Combination Set. 300mm / 12inch
COMBSETDIG	<b>NEW</b> Combination Set Cast Iron 300mm / 12 inch Rule

## VEE BLOCKS

### VEE BLOCK AND CLAMP SET

All sides are ground square and parallel to each other. V's are central, parallel and square and are matched in pairs. Made of heat treated and hardened tool steel. Precision made for machinist's and tool-makers use

Part No.	Length x Width x Height	Clamping Capacity
VB25	40 x 32 x 32mm	25mm
VB38	50 x 38 x 38mm	38mm
VB38HD	70 x 45 x 40mm	38mm
VB70	100 x 75 x 75mm	70mm

These V-Blocks can be used on top, bottom and either side. Clamps are secured in grooves machined in top & bottom surfaces.

Part No.	Length x Width x Height	Clamping Capacity
VB38TOP	70 x 63 x 45mm	38mm
VB55TOP	125 x 88 x 70mm	55mm



### CAST IRON V BLOCKS in Pairs without Clamps

Made of high quality seasoned castings. Blocks are accurately ground square & parallel. Supplied in matched & numbered pairs. Parallelism tolerance of Vee Axis to base per 6 inch length within 30 microns. Squareness tolerance of Vee Axis to end faces within 25 microns.

Part No.	Length	Height	Thickness	Width of Vee
VBCI100	100mm	65mm	41mm	50mm
VBCI125	125mm	80mm	50mm	50mm
VBCI160	150mm	90mm	63mm	82mm
VBCI200	205mm	140mm	100mm	100mm
VBCI250	255mm	168mm	125mm	125mm
VBCI300	305mm	205mm	180mm	165mm



## LATHE LIVE CENTRES DUAL BEARING - for applications up to 2000rpm

Hardened and ground High Carbon Steel - point hardened to 52-58 HRC  
Two anti-friction bearings - Single row deep groove ball bearing and taper roller bearing to absorb combined radial and thrust loads.  
Run out within 0.005mm (0.0002") and speed capacity up to 2000rpm.

Part No.	Morse Taper	Length	Feature
LLC1MTHD	1MTHD	120mm	Dual Bearings
LLC2MTHD	2MTHD	148mm	Dual Bearings
LLC3MTHD	3MTHD	185mm	Dual Bearings
LLC4MTHD	4MTHD	220mm	Dual Bearings
LLC5MTHD	5MTHD	260mm	Dual Bearings
LLC6MTHD	6MTHD	355mm	Dual Bearings

## LATHE LIVE CENTRES TRIPLE BEARINGS HIGH PRECISION

Precision Triple bearing design  
Manufactured of hardened and ground alloy steel

Part No	Morse Taper	Point Dia.	Length
LLC2MTHDPREC	2MT	15mm	140mm
LLC3MTHDPREC	3MT	15mm	155mm
LLC4MTHDPREC	4MT	20mm	180mm

## LATHE LIVE CENTRE SETS - with 7 interchangeable tips

- Hardened and ground High Carbon Steel
- Complete with seven interchangeable tips + drift
- Incorporates three anti-friction bearings
- Run out within 0.005mm (0.0002")

LLCSET2MT	2MTHD	3 bearings
LLCSET3MT	3MTHD	3 bearings

## PIPE LIVE CENTRES

- Designed to hold pipe and hollow work
- Preloaded bearings to achieve good thrust and radial load capacities
- Head made from heat treated hardened high carbon alloy steel
- Head hardened to 55-60 HRC

Part No.	Morse Taper	Head Diameter	Total Length	Angle of Bevel
LLCP2MT063	2MT	63mm	136mm	70 deg.
LLCP3MT078	3MT	78mm	172mm	70 deg.
LLCP4MT128	4MT	128mm	193mm	75 deg.
LLCP5MT147	5MT	147mm	243mm	75 deg.

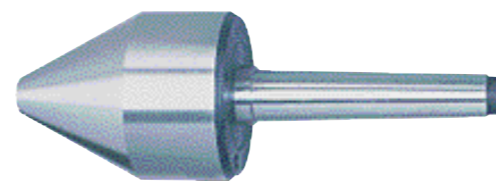

## LATHE DEAD CENTRES

- Design features to ISO298 / DIN806 standards
- 60° point solid lathe centre
- Precision ground and hardened
- Carbide tipped centres offer more wear resistance in both turning and grinding applications thus giving longer tool life and reducing costs

Part No.	Morse Taper	Length	Body Diameter
LDC0MT	0MT	70mm	9.2mm
LDC1MT	1MT	80mm	12.2mm
LDC2MT	2MT	100mm	18.0mm
LDC3MT	3MT	125mm	24.1mm
LDC4MT	4MT	160mm	31.6mm
LDC5MT	5MT	200mm	44.7mm
LDC6MT	6MT	270mm	63.8mm

Lathe DEAD CENTRES - CARBIDE TIPPED			
LDC1MTTCT	1MT	80mm	12.2mm
LDC2MTTCT	2MT	100mm	18.0mm
LDC3MTTCT	3MT	125mm	24.1mm
LDC4MTTCT	4MT	160mm	31.6mm
LDC5MTTCT	5MT	200mm	44.7mm
LDC6MTTCT	6MT	270mm	63.8mm

## LATHE HALF CENTRES - CARBIDE TIPPED

- Solid, fully hardened construction
- 60° point hardened to 60-63 HRC
- Carbide tipped centres offer more wear resistance in both turning and grinding applications thus giving longer tool life and reducing costs

Part No.	Morse Taper	Length	Feature
LDC2MTH	2MT	104mm	carbide tipped
LDC3MTH	3MT	133mm	carbide tipped

## EDGE & CENTRE FINDERS

Hardened and centreless ground to precision tolerance  
Locate working edges like shoulders, centering points and scribed lines easily & accurately

Part No.	Description	Shank	Tip
EFI	Edge Finder	1/2 inch	0.2000"
EFM	Edge Finder	12mm	5mm
ECFI	Edge & Centre Finder	1/2 inch	0.2000"

## WIGGLER & CENTRE FINDER SET

For accurately locating working points on drill presses, lathes, milling & other machines  
Set consists of Snap In Holder, Needle point, ball contact & disc contact attachments and offset indicator holder

CFSET	5 Piece Set
-------	-------------

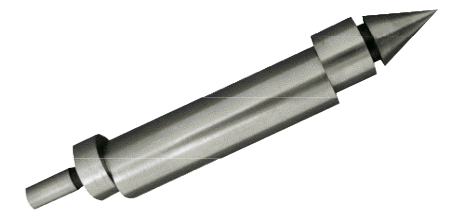

## UNIGRIP DRILL PRESS VICE

- Made of high tensile iron casting
- Used for precision jobs
- Slots for easy clamping to the tables
- Heavy duty construction

Part No.	Jaw Width	Depth of Jaw	Weight
VDP4	100mm	24mm	4.2 Kg
VDP5	125mm	30mm	5.8 Kg

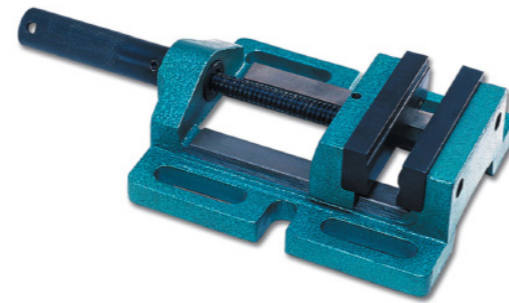

\*Vice colours may vary

**NEW**

## WELDERS CORNER ANGLE VICE

- Heavy duty vise to clamp at right angle.
- Floating head design
- Copper Plated Screw to withstand weld splatter

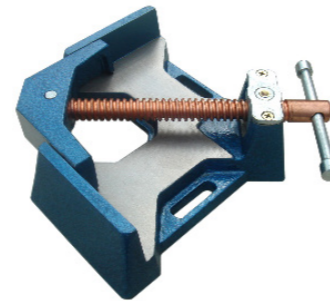

Part No.	Jaw Size	Jaw Opening	Jaw Height
MGWC0080	100x35mm	75mm	35mm

**NEW & IMPROVED**

## NEEDLE FILE SETS

NF12 - 12 PCE Needle File Set in plastic box

DFN00012 - 12 PCE Diamond Needle File Set in plastic wallet

The MAXIGEAR Standard Needle File set as well as the Diamond Needle File Set are suitable for working on a range of materials by tool and die makers, instrument makers, jewellers and hobbyist.

### Standard Needle File Set NF12:

- Effective filing
- Set contains various shapes
- Set comes in a sturdy plastic contain and a hang-sell box for easy storage

### Diamond Needle File Set DNF00012:

- Diamond particles securely bonded onto steel body
- Effective filing
- Comfortable plastic handle
- Each set contains a variety of shapes



## TOOL STEEL

Part No.	Size	Material	Shape
TS1/8x2.5	1/8 x 2-1/2	M-2 HSS	Square
TS1/8x3	1/8 x 3	M-2 HSS	Square
TS3/16x2.5	3/16 x 2.5	M-2 HSS	Square
TS3/16x3	3/16 x 3	M-2 HSS	Square
TS3/16x8	3/16 x 8	M-2 HSS	Square
TS1/4x2.5	1/4 x 2-1/2	M-2 HSS	Square
TS1/4x3	1/4 x 3	M-2 HSS	Square
TS1/4x8	1/4 x 8	M-2 HSS	Square
TS5/16x2.5	5/16 x 2-1/2	M-2 HSS	Square
TS5/16x3	5/16 x 3	M-2 HSS	Square
TS5/16x4	5/16 x 4	M-2 HSS	Square
TS5/16x8	5/16 x 8	M-2 HSS	Square
TS3/8x2.5	3/8 x 2-1/2	M-2 HSS	Square
TS3/8x3	3/8 x 3	M-2 HSS	Square
TS3/8x4	3/8 x 4	M-2 HSS	Square
TS3/8x8	3/8 x 8	M-2 HSS	Square
TS1/2x3	1/2 x 3	M-2 HSS	Square
TS1/2x4	1/2 x 4	M-2 HSS	Square
TS1/2x5	1/2 x 5	M-2 HSS	Square
TS1/2x8	1/2 x 8	M-2 HSS	Square
TS5/8x5	5/8 x 5	M-2 HSS	Square
TS3/4x5	3/4 x 5	M-2 HSS	Square
TS1x7	1 x 7	M-2 HSS	Square
TS6x100	6mm x 100	M-2 HSS	Square
TS8x100	8mm x 100	M-2 HSS	Square
TS9x100	9mm x 100	M-2 HSS	Square
TS10x100	10mm x 100	M-2 HSS	Square
TS10x200	10mm x 200	M-2 HSS	Square
TSR1/8x2-3/4	1/8 x 2-3/4	M-2 HSS	Round
TSR3/16x3-1/2	3/16 x 3-1/2	M-2 HSS	Round
TSR1/4x3	1/4 x 3	M-2 HSS	Round
TSR5/16x4-1/2	5/16 x 4-1/2	M-2 HSS	Round
TSR3/8x5	3/8 x 5	M-2 HSS	Round
TSR1/2x4	1/2 x 4	M-2 HSS	Round
TSR5/8x6	5/8 x 6	M-2 HSS	Round
TSR3/4x6	3/4 x 6	M-2 HSS	Round



### M-2 High Speed Steel

- This general purpose tool gives exceptional results on mild steel, alloys and tool steel
- Ideal for finishing applications





## TOOL HOLDERS

Machined & Ground in shiny black finish , Knurls are hob cut from HSS and heat treated

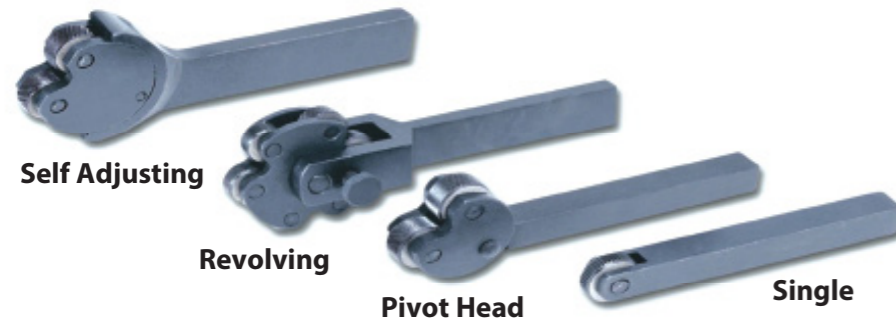

Part No.	Description	Knurl type	Knurls	Knurl Size	Bore	Shank
KTS1/2	Single Straight	Medium	1	3/4 x 1/4	1/4	12mm
KTS3/4	Single Straight	Medium	1	3/4 x 3/8	1/4	19mm
KTP	Pivot Head	Medium Diagonal	2	3/4 x 3/8	1/4	12mm
KTAS	Self Adjusting	Medium Diagonal	2	5/8 x 5/16	7/32	19 x 8mm
KTAL	Self Adjusting	Medium Diagonal	2	3/4 x 3/8	1/4	35 x 16mm
KT6S	Revolving	Fine Medium Coarse	6	5/8 x 5/16	7/32	19 x 8mm
KT6L	Revolving	Fine Medium Coarse	6	3/4 x 3/8	1/4	19 x 13mm



## REPLACEMENT KNURLING WHEELS



Part No.	Size	Bore	Description	Suit Tool
K5/8SF	5/8 x 5/16	7/32	Straight Fine	KTAS & KT6S
K5/8SM	5/8 x 5/16	7/32	Straight Medium	KTAS & KT6S
K5/8SC	5/8 x 5/16	7/32	Straight Coarse	KTAS & KT6S
K5/8CF	5/8 x 5/16	7/32	Diamond Cross Fine	KTAS & KT6S
K5/8CM	5/8 x 5/16	7/32	Diamond Cross Medium	KTAS & KT6S
K5/8CC	5/8 x 5/16	7/32	Diamond Cross Coarse	KTAS & KT6S
K5/8DLF	5/8 x 5/16	7/32	Diagonal Left Hand Fine	KTAS & KT6S
K5/8DLM	5/8 x 5/16	7/32	Diagonal Left Hand Medium	KTAS & KT6S
K5/8DLC	5/8 x 5/16	7/32	Diagonal Left Hand Coarse	KTAS & KT6S
K5/8DRF	5/8 x 5/16	7/32	Diagonal Right Hand Fine	KTAS & KT6S
K5/8DRM	5/8 x 5/16	7/32	Diagonal Right Hand Medium	KTAS & KT6S
K5/8DRC	5/8 x 5/16	7/32	Diagonal Right Hand Coarse	KTAS & KT6S
K3/4SF	3/4 x 3/8	1/4	Straight Fine	KTS3/4 KTP KTAL KT6L
K3/4SM	3/4 x 3/8	1/4	Straight Medium	KTS3/4 KTP KTAL KT6L
K3/4SC	3/4 x 3/8	1/4	Straight Coarse	KTS3/4 KTP KTAL KT6L
K3/4CF	3/4 x 3/8	1/4	Diamond Cross Fine	KTS3/4 KTP KTAL KT6L
K3/4CM	3/4 x 3/8	1/4	Diamond Cross Medium	KTS3/4 KTP KTAL KT6L
K3/4DLF	3/4 x 3/8	1/4	Diagonal Left Hand Fine	KTS3/4 KTP KTAL KT6L
K3/4DLM	3/4 x 3/8	1/4	Diagonal Left hand Medium	KTS3/4 KTP KTAL KT6L
K3/4DLC	3/4 x 3/8	1/4	Diagonal Left Hand Coarse	KTS3/4 KTP KTAL KT6L
K3/4DRF	3/4 x 3/8	1/4	Diagonal Right Hand Fine	KTS3/4 KTP KTAL KT6L
K3/4DRM	3/4 x 3/8	1/4	Diagonal Right Hand Medium	KTS3/4 KTP KTAL KT6L
K3/4DRC	3/4 x 3/8	1/4	Diagonal Right Hand Coarse	KTS3/4 KTP KTAL KT6L
K3/4SF1/4	3/4 x 1/4	1/4	Straight Fine	KTS1/2
K3/4SM1/4	3/4 x 1/4	1/4	Straight Medium	KTS1/2
K3/4SC1/4	3/4 x 1/4	1/4	Straight Coarse	KTS1/2

Pitch of Knurls Coarse = 2mm or 14 TPI Medium 1.05mm or 21 TPI Fine = 0.75mm or 33 TPI

## WHEEL DRESSERS

Sturdy Cast Iron Construction

Part No.	Description
WD0	Wheel dresser #0 for small wheels
WD1	Wheel dresser #1 for wheels to 200mm
WD2	Wheel dresser #2 for wheels > 200mm
WDSP0	Spare Cutter Wheels for #0
WDSP1	Spare Cutter Wheels for #1
WDSP2	Spare Cutter Wheels for #2

#0 - 4 wheels x 30mm O/D x 12mm wide x 8mm bore  
 #1 - 4 wheels x 40mm O/D x 12mm wide x 13mm bore  
 #2 - 6 wheels x 60mm O/D x 16mm wide x 15.25mm bore



## DIAMOND WHEEL DRESSERS

Part No.	Diamond	Shank Size
WDD0.25x6	0.25 Carat	12.7 x 150
WDD0.5	0.5 Carat	12.7 x 150
WDD0.5-3	0.5 Carat	10 x 75
WDD0.5x3	0.5 Carat	12.7 x 150
WDD0.75x6	0.75 Carat	12.7 x 150
WDD1	1 Carat	12.7 x 150
WDD1.5x6	1.5 Carat	12.7 x 150
WDD2.0x6	2 Carat	12.7 x 150
WDDT	0.5 Carat	40 x 120



WDDT  
T-Pattern



Ideal tool for dressing wheels for surface grinders, universal grinders etc.

Quality industrial diamonds.

## TAP WRENCHES - BAR TYPE

The best tool for hand tapping. Hardened and tempered jaws.

Part No.	Tap Capacity	Length	Square Range	Equivalent
TWB0	1.6 - 6.35mm	180mm	2 - 6mm	No. 00
TWB1	1.6 - 9.5mm	235mm	2.5 - 8mm	
TWB1-1/2	1 - 12mm	175mm	2 - 7 mm	No. 0
TWB2	4 - 12.7mm	280mm	4 - 9mm	No. 5
TWB3	6.35 - 19mm	375mm	4.9 - 12mm	No. 6
TWB4	6.35 - 28.75mm	500mm	5.5 - 16mm	No. 7
TWB5	19 - 38.1mm	1000mm	9 - 25mm	
TWB6	12.7 - 63.5mm	1370mm	16 - 32mm	



## TAP WRENCHES T TYPE SOLID JAW

Designed to hold taps in confined areas where it is not possible to use bar type wrenches. Heavy knurled cap for a better grip. Ground finish.

Part No.	Suit Taps
TWT1	2 - 5mm
TWT2	3 - 6mm
TWT3	6 - 12mm
TWTSET	TWT1, TWT2, TWT3



## TAP WRENCHES T TYPE EXTRA LONG

Hardened & tempered replaceable jaws

Part No.	Tap Capacity	Length
TWT2L	4 - 8mm	330mm
TWT3L	6 - 12mm	330mm



## TAP WRENCHES T TYPE RATCHETING

Part No.	Tap Capacity
TWTR2	3 - 6mm
TWTR3	6 - 12mm
TWTR3-12	3 - 12mm



## TAP WRENCHES T TYPE RATCHETING EXTRA LONG

Part No.	Tap Capacity	Length
TWTR2L	3 - 6mm	330mm
TWTR3L	6 - 12mm	330mm

## ROUND DIE STOCK HANDLES

For holding adjustable round split dies

Three set screw pattern. Single piece construction

Part No.	Die OD	Length
DH5/8	5/8	140mm
DH13/16	13/16	170mm
DH1	1 inch	220mm
DH1-5/16	1-5/16	250mm
DH1-1/2	1-1/2	300mm
DH1-3/4	1-3/4	370mm
DH2	2 inch	380mm
DH2-1/4	2-1/4	420mm
DH2-1/2	2-1/2	480mm
DH3	3 inch	560mm





### PIN SPANNERS



Part No.	Description	Colour
PSRED	Pins 5mm on 35mm centres	Red
PSBE	Pins 4mm on 20mm centres	Blue
PSBK	Pins 5mm on 23mm centres	Black
PSG	Pins 4mm on 28mm centres	Grey
PSADJ	Adjustable light duty pin spanner	
PSZINC	Flat style 5mm on 35mm centres	Zinc

### FLANGES FOR ANGLE GRINDERS

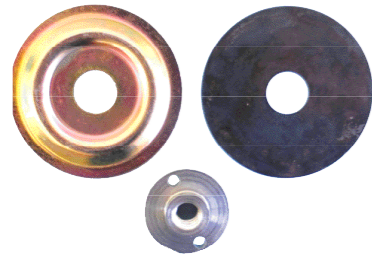

Part No.	Description
FSC14X2	Flange Set for cut-off wheels 14 x 2 x 90mm
F14X2	Flange 45mm diameter M14 x 2.0 thread
FSCW	Hard washer 90mm diameter M14x2.0 thread
FSCBF	Bottom Flange 90mm diameter M14 x 2.0 thread
F10X1.5	Flange 32mm diameter 100mm Grinder M10 x 1.5

### PLANER BLADES



BACKING PADS - BLACK			SWISS MANUFACTURED		
Part No	Size	Thread	Density		
BP100X10X125B	100	M10 x1.25	HARD		
BP100X10X15B	100	M10 x 1.5	HARD		
BP115X14X2B	115	M14 x 2	HARD		
BP125X14X2B	125	M14 x 2	HARD		
BP178X14X2B	178	M14 x 2	HARD		

BACKING PADS - FLEXIBLE NYLON BLACK					
Part No	Size	Thread	Grits	Flexipads	
BP100x10x15BISO	100	M10 x 1.5	80 + FINER	11502	
BP115X14X2BISO	115	M14 x 2	80 + FINER	11513	
BP125X14X2BISO	125	M14 x 2	80 + FINER	11523	
BP178X14X2BISO	178	M14 x 2	80 + FINER	11532	

BACKING PADS - WHITE			SWISS MANUFACTURED		
Part No	Size	Thread	Density	Grits	Flexipads
BP100X10X15W	100	M10 x 1.5	MEDIUM		
BP115X14X2W	115	M14 x 2	MEDIUM		
BP125X14X2W	125	M14 x 2	MEDIUM		
BP178X14X2W	178	M14 x 2	MEDIUM		

BACKING PADS - FLEXIBLE NYLON WHITE						
Part No	Size	Thread	Foam layer	Density	Grits	Flexipads
BP100X10X15WISO	100	M10 x 1.5			60 + FINER	11102
BP115X14X2WISO	115	M14 x 2			60 + FINER	11113
BP125X14X2WISO	125	M14 x 2			60 + FINER	11123
BP178X14X2WISO	178	M14 x 2			60 + FINER	11132
BP178X5/8WISO	178	5/8 UNC			60 + FINER	11131

BACKING PADS - TURBO HARD FLEXIBILITY					
Part No	Size	Thread	Density	Grits	Flexipads
BP100X10X15T	100	M10 x 1.5	HARD	36 + finer	11703
BP115X14X2T	115	M14 x 2	HARD	36 + finer	11713
BP125X14X2T	125	M14 x 2	HARD	36 + finer	11723
BP178X14X2T	178	M14 x 2	HARD	36 + finer	11732

**NEW**

BACKING PADS - EXTRA LONG HEAVY DUTY 'GRIPPER SYSTEM' - SWISS MANUFACTURED					
Part No	Size	Thread	Density		
BP100VLHCK	100	M14 x 2	HARD		
BP100VLHPL	100	M14 x 2	HARD		
BP115VLHCK	115	M14 x 2	HARD		
BP125VLHCK	125	M14 x 2	HARD		
BP125VLHPL	125	M14 x 2	HARD		
BP175VLHCK	175	M14 x 2	HARD		



FOAM LAYER

NO FOAM LAYER



**SANDER POLISHER PADS - SOFT DENSITY VELCRO**

Part No	Size	Thread	Foam layer	Density	Max RPM
BP125x14x2VEF12S	125	M14 x 2	15mm	Soft	12,250

**SANDER POLISHER PADS - MEDIUM DENSITY VELCRO**

Part No	Size	Thread	Foam layer	Density	Max RPM
BP125X14X2VEF12M	125	M14 x 2	15mm	Medium	6,500
BP150X14X2VEF12M	150	M14 x 2	15mm	Medium	5,500

**BACKING PADS - MEDIUM FLEXIBILITY VELCRO NO FOAM LAYER**

Part No	Size	Thread	Foam layer	Density	Max RPM
BP125X14X2VEGP	125	M14 x 2	NONE	FIRM	6,500

**POLISHING COMPOUNDS**

Part No.	Description	
PCBRL	Polishing compound brown	Tripoli
Non ferrous & plastics - soft metals ie Aluminium, brass, copper, diecast - combined cutting & finishing. General purpose - use with stitched rag or loose leaf calico buff		
PCGY	Polishing compound grey	Ferropol
Fast cutting for polishing steel & stainless - use with stitched sisal buff Used to cut back light scratches		
PCWH	Polishing compound white	Hyfin
Fast cutter for all metals - use with sisal buff for cutting then calico for finishing		
PCGN	Polishing compound green rouge	Orion BB
For mirror finish on all metals when using calico mops		
PCBLS	Polishing compound	Multishine
Fine finish for non ferrous metals - for high gloss polish use loose leaf calico buff		
PCUN	Polishing compound liquid	Unipol
Liquid polish for metals, plastic and stone		
PCBB	Polishing compound tripoli fine	Tripoli BB
Fine finish for non ferrous metals		



**ALUMINIUM LUBRICANTS**

Used for lubricating circular saws, band saws etc when cutting aluminium & non ferrous metals & reduce clogging of sanding discs & belts

\*\* Weights are approximate and can vary\*\*

Part No.	Description
AL700	Tallow base lubricant 500 gram tube
WAX600	White Stearene Wax in a tray 600 gram



**ABRASIVE RESTORERS**

Cleaning stick for Abrasive Belts and discs

Part No.	Description
ARL032	Natural Rubber Large 32 x 32 x 200mm
ARM050	Natural Rubber Magnum 50 x 50 x 200mm



**VELCRO CONVERTER DISCS & ABRASIVE DISCS**

Part No.	Description
CD125B	Converter Disc 125mm
CD150B	Converter Disc 150mm
CD180B	Converter Disc 180mm
CD230B	Converter Disc 230mm
CD125D	Converter Disc & Abrasive Disc 125mm
CD150D	Converter Disc & Abrasive Disc 150mm
CD180D	Converter Disc & Abrasive Disc 180mm
CD230D	Converter Disc & Abrasive Disc 230mm

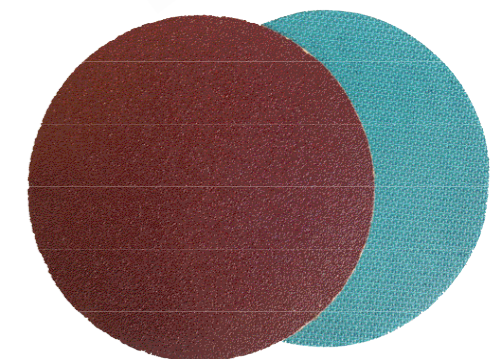

Converter Discs accept Hook & Loop type abrasive discs on one side and the other side is adhesive stick on.



## TAPERED SPINDLES

TAPERED SPINDLES FOR BENCH GRINDERS • MANUFACTURED IN AUSTRALIA

Part No.	Description
TS12MLH	M12 x 1.75 thread Left Hand 140mm length
TS12MRH	M12 x 1.75 thread Right Hand 140mm length
TS1/2WLH	1/2 BSW thread Left Hand 140mm length
TS1/2WRH	1/2 BSW thread Right Hand 140mm length
TS16MLH	M16 x 2.0 thread Left Hand 140mm length
TS16MRH	M16 x 2.0 thread Right Hand 140mm length
TS16X1.5LH	M16 x 1.5 thread Left Hand 140mm length
TS16X1.5RH	M16 x 1.5 thread Right Hand 140mm length
TSS/8WLH	5/8 BSW thread Left Hand 140mm length
TSS/8WRH	5/8 BSW thread Right Hand 140mm length
TSS/8FLH	5/8 UNF thread Left Hand 140mm length
TSS/8FRH	5/8 UNF thread Right Hand 140mm length
TS5/8PRH	5/8 inch 10mm untapped Pilot Right Hand 140mm length
TS20MRH	M20 x 2.5 thread Right Hand 140mm length
TS1WLH	1" BSW thread Left Hand
TS1WRH	1" BSW thread Right Hand

Spindles described as "Pilot" have 10mm untapped hole that can be drilled and tapped.

## TAPERED SPINDLES FOR STRAIGHT GRINDERS • MANUFACTURED IN AUSTRALIA

TSS12M	M12 x 1.75 thread Right Hand 90mm length
TSS14M	M14 x 2 thread Right Hand 90mm length
TSS1/2W	1/2 BSW thread Right Hand 90mm length
TSS10PLH	10mm Untapped Pilot Left Hand 90mm length
TSS10PRH	10mm Untapped Pilot Right Hand 90mm length

Spindles described as "Pilot" have 10mm untapped hole that can be drilled and tapped.

## TAPERED SPINDLES WITH ROUND SHANK • MANUFACTURED IN AUSTRALIA

TS06MRDASH	6mm Round Shank Right Hand 85mm length
TS12MRDASH	12mm Round Shank Right Hand 95mm length

Can be used in straight grinders / polishers or in drill chucks with 6-12mm capacity.

## EXTENSION SPINDLES FOR BENCH GRINDERS • MANUFACTURED IN AUSTRALIA

ES1/2WLH	1/2 BSW thread Left Hand 135mm overall length
ES1/2WRH	1/2 BSW thread Right Hand 135mm overall length
ES16MLH	M16 thread Left Hand 135mm overall length
ES16MRH	M16 thread Right Hand 135mm overall length
ES5/8WLH	5/8 BSW Left Hand 135mm overall length
ES5/8WRH	5/8 BSW Right Hand 135mm overall length
ES5/8FLH	5/8 UNF Left Hand 135mm overall length
ES5/8FRH	5/8 UNF Right Hand 135mm overall length

## EXTENSION SPINDLES FOR ANGLE GRINDERS • MANUFACTURED IN AUSTRALIA

ESS14-5/8	M14 Female thread 5/8-11 Male thread 55mm length
ESS5/8-14	5/8-11 Female thread M14 Male thread 55mm length
ESS14MM	M14 Female thread M14 Male thread 55mm length

ESS14-5/8 is for using wire brushes etc with 5/8" female threads on angle grinders with 14mm spindles  
ESS5/8-14 is for using wire brushes etc with 14mm female threads on angle grinders with 5/8" spindles

Note - All lengths are approximate and subject to change as per Manufacturer's Specifications.



## POLISHING MOPS - LOOSE LEAF CALICO (UNSTITCHED)

Part No.	Size	Folds	Width
PMC038050	38 mm	50	13 mm
PMC038100	38 mm	100	36 mm
PMC050050	50 mm	50	13 mm
PMC050100	50 mm	100	36 mm
PMC050125	50 mm	125	
PMC075050	75 mm	50	13 mm
PMC075100	75 mm	100	36 mm
PMC100050	100 mm	50	13 mm
PMC100100	100 mm	100	36 mm
PMC100150	100 mm	150	
PMC125100	125 mm	100	36 mm
PMC150050	150 mm	50	13 mm
PMC150100	150 mm	100	36 mm
PMC150150	150 mm	150	
PMC150200	150 mm	200	
PMC200025	200 mm	25	
PMC200050	200 mm	50	13 mm
PMC200100	200 mm	100	36 mm
PMC200150	200 mm	150	
PMC200200	200 mm	200	
PMC250050	250 mm	50	13 mm
PMC250100	250 mm	100	36 mm
PMC250200	250 mm	200	
PMC300050	300 mm	50	13 mm
PMC300100	300 mm	100	36 mm

Loose Leaf Calico Mop



Sisal Stitched Mop



Stitched Rag Mop



## POLISHING RAG MOPS - STITCHED RAG

Part No.	Size	Sections	Width
PMST0381	38 mm	1 section	13mm
PMST0382	38 mm	2 sections	25mm
PMST0501	50 mm	1 section	13mm
PMST0502	50 mm	2 sections	25mm
PMST0503	50 mm	3 sections	38mm
PMST0751	75 mm	1 section	13mm
PMST0752	75 mm	2 sections	25mm
PMST1001	100 mm	1 section	13mm
PMST1002	100 mm	2 sections	25mm
PMST1003	100 mm	3 sections	38mm
PMST1501	150 mm	1 section	13mm
PMST1502	150 mm	2 sections	25mm
PMST1503	150 mm	3 sections	38mm
PMST2001	200 mm	1 section	13mm
PMST2002	200 mm	2 sections	25mm
PMST2003	200 mm	3 sections	38mm
PMST2004	200 mm	4 sections	50mm
PMST2501	250 mm	1 section	13mm
PMST2502	250 mm	2 sections	25mm
PMST2503	250 mm	3 sections	38mm
PMST2504	250 mm	4 sections	50mm
PMST3001	300 mm	1 section	13mm
PMST3002	300 mm	2 sections	25mm
PMST3003	300 mm	3 sections	38mm
PMST3004	300 mm	4 sections	50mm
PMST3502	350 mm	2 sections	25mm
PMST3504	350 mm	4 sections	50mm

## POLISHING MOPS - SISAL STITCHED

Part No.	Size	Sections	Width	Colour
PMS0381	38 mm	1 section	13mm	Untreated
PMS0382	38 mm	2 section	25mm	Untreated
PMS0501	50 mm	1 section	13mm	Untreated
PMS0502	50 mm	2 section	25mm	Untreated
PMS0503	50 mm	3 section	38mm	Untreated
PMS0751	75 mm	1 section	13mm	Untreated
PMS0752	75 mm	2 section	25mm	Untreated
PMS1001	100 mm	1 section	13mm	Untreated
PMS1002	100 mm	2 section	25mm	Untreated
PMS1501	150 mm	1 section	13mm	Untreated
PMS1502	150 mm	2 section	25mm	Untreated
PMS2001	200 mm	1 section	13mm	Untreated
PMS2002	200 mm	2 section	25mm	Untreated
PMS2003	200 mm	3 section	38mm	Untreated
PMS2004	200 mm	4 section	50mm	Untreated
PMS2501	250 mm	1 section	13mm	Untreated
PMS2502	250 mm	2 section	25mm	Untreated
PMS3001	300 mm	1 section	25mm	Untreated
PMS3002	300 mm	2 section	25mm	Untreated
PMS3004	300 mm	4 section	50mm	Untreated
PMS3504	350 mm	4 section	50mm	Untreated

## POLISHING MOPS - LAMBSWOOL BONNETS

Part No.	Size
PB180	180 mm
PB200	200 mm





## POLISHING MOPS - NONWOVEN MOPS

Generally used as a cut and polish wheel where a clean satin finish is required. Non woven wheels are sensitive to heat and must not run too fast or with too much pressure.

Part No.	Size	Sections	Thickness	Colour
PMGNW0506	50mm	6	42mm	Green
PMGNW1003	100mm	3	21mm	Green
PMGNW1503	150mm	3	21mm	Green
PMGNW1506	150mm	6	42mm	Green
PMMNW0506	50mm	6	42mm	Maroon
PMMNW1003	100mm	3	21mm	Maroon
PMMNW1503	150mm	3	21mm	Maroon
PMMNW1506	150mm <td 6	42mm	Maroon	

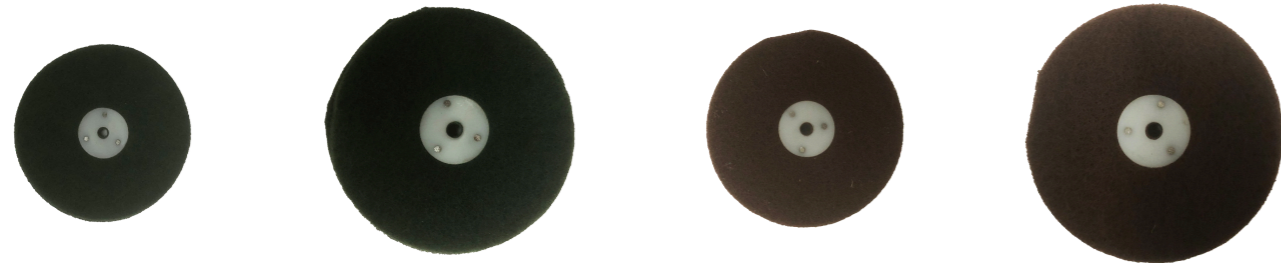

## IN-LINE LUBRICATORS - MADE IN THE USA

Designed for use with tools being used too far away from compressor to be lubricated by a permanently mounted unit. Suitable for use on a wide range of tools, including air scribes, chipping hammers, needle scalars and piston scalars.

Part No.		Max working pressure	Oil WT. Rec	Air Flow 70 PSI
TX-0L	1.4 fl.oz (42 ml) in-line lubricator 1/2" BSPF	500	10 WT.	30 CFM
TX-1L	3.7 fl.oz (111 ml) in-line lubricator 3/4" BSPF	260	10 WT.	70 CFM
TX-2L	11 fl.oz (330ml) in-line lubricator 3/4" BSPF	300	10 WT.	70 CFM
TX-3L	16 fl.oz (480 ml) in-line lubricator 1" BSPF	250	10 WT.	150 CFM



## IN-LINE FILTER LUBRICATORS - MADE IN THE USA

One of the most common repairs an air tool undergoes is disassembly to clean foreign material out of the valve assembly. In-line Filter Lubricators help prevent this from happening. The 40 micron filter can be easily cleaned or replaced.



Part No.		Max working pressure	Oil WT. Rec	Air Flow 70 PSI
TX-0L-F	1.4 fl.oz (42 ml) in-line filter lubricator 1/2" BSPF	500	10 WT.	30 CFM
02008	40 Micron bronze filter to suit TX-0L-F			
TX-1L-F	3.7 fl.oz (111 ml) in-line filter lubricator 3/4" BSPF	260	10 WT.	70 CFM
02013	40 Micron bronze filter to suit TX-1L-F			

## SAFETY LOCK CABLE & AIR SCRIBERS - MADE IN THE USA



### Safety Lock Cables

Durable heavy duty steel cables help prevent injury from accidental separation of clamp and coupling devices

TX-SLC1 1/8" cable x 20"  
TX-SLC2 1/4" cable x 38"



### TXAS1 Air Scribe

Adjustable throttle for a variety of jobs  
Carbide tipped stylus for longer life  
Equipped with a flexible hose & filter with a 3/8" NPT fitting

## VENTURI AIR MOVERS - MADE IN THE USA

Air movers or air horns are used wherever there is a need to disperse fumes, move air into confined spaces, or cool machinery or products with a blast of directed air.

Part No	Description
TX3AMS	6" Horn x 16.75" length air mover
TX3AM	7" Horn x 30.5" length air mover
TX6AM	12.5" Horn x 44.25" length air mover
TX8AM	15.5" Horn x 46.06" length air mover
TX10AM	15.75" Horn x 48" length air mover



## PIN CHUCKS

### PIN CHUCK KIT

Designed for holding small drills. 3 interchangeable collets  
0 - 0.8mm, 0.8 - 1.60mm, & 1.60 - 2.40mm

PCHUCK	Pin Chuck Kit with 3 collets
--------	------------------------------

### MICRO CHUCK

For use in drill press or hand held tools. Suitable for drills 0.3 - 1.00mm  
Can be held in any 1/8 or 3/16 collet or 3 jaw drill chuck

PMICRO	Micro chuck for 0.3 - 1.00mm drills
--------	-------------------------------------

### DOUBLE ENDED PIN VICE

Has two 4 jaw double ended collets  
Popular tool for jewellers, watch makers, model makers

PVDE	4 Jaw Pin Vice 0 - 3.2mm
------	--------------------------

### PIN VICE SET

PV4001S	4 Jaw Pin vices 0.8 through 4.85mm
---------	------------------------------------

### TWEezer SET

6 Piece Set contains 2 straight, 1 knurled straight, 2 bent point & 1 self locking  
Lengths vary from 125 - 175mm

TWSET	Stainless Steel Hobbyist Set
-------	------------------------------

### SUPERFLEX CURVE

Product innovation, designed and manufactured by Grinding Techniques in accordance with European Safety Standards ensures exceptional safety for hand held radii and contour cutting. Used for hand-held grinders, suitable for Stainless and Carbon steel, High alloy steel and Mild steel. (Available in Shape 28).



MGCCD125	Super Flex Curve Disc 125 x 2.1 x 23mm
----------	--



## Marking Tools

NEW

**Tajima**  
Since 1909

### CHALK-RITE II™ EXTRA BOLD



### CHALK-RITE II™ ULTRA THIN



Code	Item	Details	Inner	Outer
CR201R-PR	Chalk-Rite II™ Extra Bold Line & Dye	1.0mm x 30m Line, 5 Gear Fast Wind	4	24
CR202B	Chalk-Rite II™ Ultra Thin Line & Chalk	0.5mm x 30m Line + Chalk, 5 Gear Fast Wind	4	24

### CHALK-RITE II™ JAM FREE



Code	Item	Details	Inner	Outer
CR301JF	Chalk-Rite II™ Jam Free	1.0mm x 30m Line, 5 Gear Fast Wind	8	32
CR101S	Chalk-Rite II™ Auto wind	1.0mm x 7m Line, Auto Wind	6	36

**SNAP LINE DYE**

**MICRO CHALK**

**CHALK-RITE II™ LINE**



Code	Item	Details	Inner	Outer
PLCDR300	Snap Line Dye Dark Red	300g Semi Permanent Dye Powder	6	60
PLGBK300	Snap Line Dye Black	300g Semi Permanent Dye Powder	6	60
PLCB300	Micro Chalk Blue	300g Chalk Powder	6	60
PLGR300	Micro Chalk Red	300g Chalk Powder	6	60
PLCY300	Micro Chalk Yellow	300g Chalk Powder	6	60
PLGW300	Micro Chalk White	300g Chalk Powder	6	60
PLITOL	Chalk-Rite II™ Extra Bold Line	1.0mm x 30m Replacement Snap Line	10	100
PLTOS	Chalk-Rite II™ Ultra Thin Line	0.5mm x 30m Replacement Snap line	10	100

**INK-RITE II™ SNAP LINE AUTO WIND**

**INK-RITE II™ SNAP LINE INK**



Code	Item	Details	Inner	Outer
IR101S	Ink-Rite II™ Snap Line Auto Wind	0.6mm x 7.5m Line, 5 Gear Fast wind	6	36
PSB2180	Ink-Rite II™ Snap Line Ink Black	180ml Quick Dry Ink	12	60
PSR2180	Ink-Rite II™ Snap Line Ink Red	180ml Quick Dry Ink	12	60
PSW3180	Ink-Rite II™ Snap Line Ink White	180ml Wet Weather Ink	12	60

**SNAP BLADE KNIVES**



Code	Item	Details	Inner	Outer
LC360	GRI® 9mm Knife	Precision Craft, Auto-Lock Blade Lock	10	120
LC580	GRI® 18mm Knife	Heavy Duty, Auto-Lock Blade Lock	10	120
LC660	GRI® 25mm Knife	Rock Hard, Auto-Lock Blade Lock	10	120

**SNAP BLADE KNIVES**



Code	Item	Details	Inner	Outer
LC500	Endura™ 18mm Knife	Display box, Cellophane pack	40	120
LC500B	Endura™ 18mm Knife	Blester pack	10	120
LC850	Rock Hard® 25mm Knife	Bonus 3 blades & Storage case	18	72

**REPLACEMENT BLADES**

**9mm**



Code	Item	Details	Inner	Outer
LCB30C	Endura Blade™ 9mm 10Pk	Snap Segment Blades	10	120
LCB30-50	Endura Blade™ 9mm 50Pk	Snap Segment Blades	10	100

**18mm**



Code	Item	Details	Inner	Outer
LCB50	Endura Blade™ 18mm 10pk	Snap Segment Blades	10	120
LCB50-50	Endura Blade™ 18mm 50pk	Snap Segment Blades	10	50
LCB50S	Endura Blade™ Solid 18mm 10pk	Solid Blades	10	120

**25mm**



Code	Item	Details	Inner	Outer
LCB65	Rock Hard Blade™ 25mm 10pk	Snap Segment Blades	10	120
LCB65-20	Rock Hard Blade™ 25mm 20pk	Snap Segment Blades	10	50
LCB65S	Rock Hard Blade™ 25mm 10pk	Solid Blades	10	120

**UTILITY KNIVES**



Code	Item	Details	Inner	Outer
VR101	V-Rex™ Fixed Blade Knife	Bonus 3 Blades	12	72
VR102	V-Rex™ Retractable Blade Knife	Bonus 3 Blades	12	72
VR103	V-Rex™ Safety Knife	Bonus 3 Blades	12	72

**UTILITY BLADES**



Code	Item	Details	Inner	Outer
VRB5B	V-Rex™ Blade 5pk		10	120
VRB10B	V-Rex™ Blade 10pk	Dispenser Pack	10	120
VRB50B	V-Rex™ Blade 50pk	Dispenser Pack	10	120
VRB100B	V-Rex™ Blade 100pk	Dispenser Pack	10	120

**PULL SAWS AND BLADES**



Code	Item	Details	Inner	Outer
JPR265	Japan Pull™ Saw & 265mm blade	Ergonomic Non-slip Curved Handle	6	24
<b>GNE230</b>	<b>Japan Pull™ Saw Blade 230mm</b>	<b>21 TPI, Replacement Blade</b>	<b>24</b>	<b>120</b>
GNB250	Japan Pull™ Saw Blade 250mm	19 TPI, Replacement Blade	24	120
<b>GNE265</b>	<b>Japan Pull™ Saw Blade 265mm</b>	<b>16 TPI, Replacement Blade</b>	<b>24</b>	<b>120</b>
GNB300	Japan Pull™ Saw Blade 300mm	13 TPI, Replacement Blade	24	120

**FOLDING PRUNING SAWS AND BLADES**



Code	Item	Details	Inner	Outer
GK-G210	G-Saw™ Rapid-Pull 210mm	Folding Handle, Lock Blade	6	60
<b>GK-G240</b>	<b>G-Saw™ Rapid-Pull 240mm</b>	<b>Folding Handle, Lock Blade</b>	<b>6</b>	<b>60</b>
GKB-G210	G-Saw™ Spare Blade 210mm	Replacement Blade	12	120
<b>GKB-G240</b>	<b>G-Saw™ Spare Blade 240mm</b>	<b>Replacement Blade</b>	<b>12</b>	<b>120</b>

**SCRAPERS & BLADES**



Code	Item	Details	Inner	Outer
SCR300	Scrape-Rite™ 300mm Handle	Includes 3 x 18mm blades	4	24
<b>SCR600</b>	<b>Scrape-Rite™ 600mm Handle</b>	<b>Includes 3 x 18mm blades</b>	<b>4</b>	<b>24</b>
LCB50S	Endura Blade™ Solid 18mm 10pk	Solid Replacement Blades	10	120
<b>LCB65S</b>	<b>Rock Hard Blade™ 25mm 10pk</b>	<b>Solid Replacement Blades</b>	<b>10</b>	<b>120</b>

**LAYOUT TOOLS**

**PLASTER TOOLS**



Code	Item	Details	Inner	Outer
PZB-400GP	Plumb-Rite™ Bob 400g	Self-Retracting Line, Quick Stabilizing Bob	6	24
<b>SLT-100</b>	<b>Slant 100 Rotary Angle Measre</b>	<b>One Hand Operation Angle Measure</b>	<b>6</b>	<b>36</b>
TBYD180	Combination Plaster Rasp 180mm	3 Grinding Sections, Dual Action, Clog Free	6	36
<b>TBK180-H45</b>	<b>Plaster Beveling Tool 45°</b>	<b>Includes 1 Blade &amp; Resizing Tool</b>	<b>6</b>	<b>36</b>

**CAULKING GUNS**



Code	Item	Details	Inner	Outer
CNV-JUST	Convoy Just™ Yellow Caulking Gun	Auto Flow Stop, for 300 to 400ml cartridges	6	24
CNV-100LT	Convoy Lite™ Caulking Gun	Ultra Light Weight	6	24
CNV100SP12	Convoy Super™ 12 Caulking Gun	For Thick Viscous Materials	6	24
CNV100SP26	Convoy Super™ 26 Caulking Gun	For Extra Thick Viscous Materials	6	24

**MEASURING TAPES**



Code	Item	Details	Inner	Outer
G5P80MYL	G-Lock™ 8m Tape	Metric	4	40
G5PA0MYL	G-Lock™ 10m Tape	Metric	4	40
PIT 20	Pit Measure Adhesive Tape 2m		10	80
PIT 50	Pit Measure Adhesive Tape 5m		10	80

**STANDARD TIE DOWNS**



Code	Item	Lashing Capacity	Box Qty
153	Ratchet Tie Down 3m 4pk Green	200kg	4
<b>130</b>	<b>Ratchet Tie Down 4m 1pk Green</b>	<b>340kg</b>	<b>6</b>
138	Ratchet Tie Down 2m 2pk Green	340kg	6
<b>145</b>	<b>Ratchet Tie Down 4m 4pk Green</b>	<b>340kg</b>	<b>4</b>



Code	Item	Lashing Capacity	Box Qty
141	Ratchet Tie Down 4m 1pk Orange	680kg	4
<b>140</b>	<b>Ratchet Tie Down 3m 2pk Orange</b>	<b>680kg</b>	<b>3</b>

**RATCHET X TIE DOWNS**



Code	Item	Lashing Capacity	Box Qty
339	Ratchet X Tie Down 4.5m 1pk Green	340kg	4
<b>838</b>	<b>Ratchet X Tie Down 4m 2pk Green</b>	<b>340kg</b>	<b>4</b>
345	Ratchet X Tie Down 3.5m 4pk Green	340kg	4



Code	Item	Lashing Capacity	Box Qty
341	Ratchet X Tie Down 4.5m 1pk Orange	680kg	4
<b>840</b>	<b>Ratchet X Tie Down 4m 2pk Orange</b>	<b>680kg</b>	<b>4</b>



Code	Item	Lashing Capacity	Box Qty
151	Ratchet X Tie down 5.5m 1pk Yellow	1130kg	4
<b>150</b>	<b>Ratchet X Tie down 4.5m 2pk Yellow</b>	<b>1130kg</b>	<b>3</b>
143	Ratchet X Tie down 7.6m 1pk Yellow	2265kg	3
<b>807</b>	<b>Ratchet X Tie down 10m 1pk Yellow</b>	<b>2265kg</b>	<b>3</b>

**RATCHET X TIE DOWNS - CAMO**



Code	Item	Lashing Capacity	Box Qty
364	Ratchet X Camo 3m 2pk Camo	340kg	4
<b>305</b>	<b>Ratchet X Camo 4.2m 4pk Camo</b>	<b>340kg</b>	<b>4</b>

**RETRACTABLE TIE DOWNS**



Code	Item	Lashing Capacity	Box Qty
170	Retract Tie Down 1.8m 2pk Green	340kg	3
<b>408</b>	<b>Retract Tie Down 1.8m 4pk Green</b>	<b>340kg</b>	<b>3</b>
173	Retract Tie Down 3m 2pk Orange	680kg	3

**CAMBUCKLE TIE DOWNS**



Code	Item	Lashing Capacity	Box Qty
105	Cambuckle Lash Straps 3.6m 2pk Green	100kg	6
<b>136</b>	<b>Cambuckle Tie Down 2m 2pk Green</b>	<b>270kg</b>	<b>6</b>
137	Cambuckle Tie down 2.4m 2pk Orange	500kg	4
<b>148</b>	<b>Cambuckle Tie down 3m 4pk Green</b>	<b>200kg</b>	<b>4</b>

**STANDARD BUNGEE**



**SUPER STRONG BUNGEE**



Code	Item	Details	Box Qty
190	Bungee Cord	61cm 2pk Green	14
<b>191</b>	<b>Bungee Cord</b>	<b>91cm 2pk Orange</b>	<b>12</b>
192	Bungee Cord	122cm 2pk Yellow	10
<b>118</b>	<b>Bungee Cord</b>	<b>Assorted 20pcs</b>	<b>4</b>
183	Super Strong Bungee Cord	60cm 1pk Green	9
<b>184</b>	<b>Super Strong Bungee Cord</b>	<b>90cm 1pk Orange</b>	<b>9</b>
185	Super Strong Bungee Cord	120cm 1pk Yellow	9

**FLAT STRAP BUNGEE**



**BUNGEE X ADJUSTABLE**



Code	Item	Details	Box Qty
230	Bungee Flat Strap	61cm 2pk Green	12
<b>231</b>	<b>Bungee Flat Strap</b>	<b>91cm 2pk Orange</b>	<b>12</b>
232	Bungee Flat Strap	122cm 2pk Yellow	8
<b>215</b>	<b>Bungee Flat Strap</b>	<b>Assorted 10pk</b>	<b>4</b>
407	Bungee X Adjustable	40-60cm 1pk Green	7
<b>408</b>	<b>Bungee X Adjustable</b>	<b>55-80cm 1pk Orange</b>	<b>7</b>
409	Bungee X Adjustable	75-120cm 1pk Yellow	7

**TARP STRAPS**



Code	Item	Details	Box Qty
270	Tarp Strap	38cm 35pk	35
<b>271</b>	<b>Tarp Strap</b>	<b>53cm 20pk</b>	<b>20</b>
272	Tarp Strap	79cm 15pk	15
<b>273</b>	<b>Tarp Strap</b>	<b>104cm 15pk</b>	<b>15</b>

**ADJUSTABLE TARP STRAPS**



Code	Item	Details	Box Qty
374	Adjustable Tarp Strap	86cm 15pk	15
<b>118</b>	<b>Tarp Strap Assortment</b>	<b>10pk</b>	<b>4</b>

**ACCESSORIES**



Code	Item	Details	Box Qty
114	Mini Bungee Cords	20pk	9
111	Soft Ties	45cm 2pk Green	18
110	Toggle Balls Adjustable	5-30cm 8pk	9

**ACCESSORIES**



Code	Item	Details	Box Qty
221	Anchor Points Universal	2pk	5
104	Carabiner Hooks	2pk Assorted colours	22

**Marking Tools**

**PENCILS**



Code	Item	Details	Inner	Outer
CPSINGLE	Carpenters Pencil Single		72	
PEN-HOLD	Pencil Holder		12	
CP10	Carpenters Pencil 10pk	Includes bonus Sharpener	9	72
SHARP	Verasharp Sharpener - Box 25	Use for Pencils and Crayons	25	100

**CRAYONS**



Code	Item	Details	Inner	Outer
YCRAY	Crayon Yellow	No Melt Lumber Crayon	12	144
RCRAY	Crayon Red	No Melt Lumber Crayon	12	144
BCRAY	Crayon Blue	No Melt Lumber Crayon	12	144
BLCRAY	Crayon Black	No Melt Lumber Crayon	12	144
CRAYHOLD	Crayon Holder	Extends Crayon Life	12	

## Safety Products

NEW



### TTL EARMUFFS - STANDARD



Code	Item	Details	Inner	Outer
SEM002	Standard Earmuffs	Rating 28db, Class 5	6	24
SSLEM002	Standard Earmuffs Slimline	Rating 28db, Class 5	6	24

## Safety Products

NEW



### TTL KNEE PADS



Code	Item	Details	Inner	Outer
KP001	Knee Pads Gel	Gel Cushioned Comfort	1pr	10
KPS002	Knee Pads Standard	Pro Swivel-Flex Knee Pads	1pr	10



## Safety Products

### TTL EARMUFFS - ELECTRONIC



Code	Item	Details	Inner	Outer
EM001	Electronic Earmuffs	Noise cancelling, Rating 29db, Class 5	12	
SLEM001	Electronic Earmuffs Slim Line	Noise cancelling, Rating 22db, Class 4	6	24

### TTL SAFETY TAPES



Code	Item	Details	Box Qty
DANSAFE	Safety Tape	100m Danger	18
RWSAFE	Safety Tape	100m Red & White	18
CAUSAFE	Safety Tape	100m Caution	18
BYSAFE	Safety Tape	100m Black & Yellow	18



**NEW** Tool Belts

**TTL TOOL BELTS**



Code	Item	Details	Box Qty
NB001	Nail Bag 12 pocket	Oil-Tanned Split Leather, Adjustable Belt	15
GA12SL2	Construction Apron 12 Pocket	Split Suede Leather Adjustable Belt ( Out of stock)	25
CA18PL	Construction Apron 18 Pocket	Lightweight & Durable Polyester, Adjust Belt	20

**TTL TOOL POCKETS**



Code	Item	Details	Box Qty
NB10OSL	Nail Bag 10 Pocket Leather	Oil-Tanned Split Leather	25
NB10SL	Nail Bag 10 Pocket Suede	Split Leather	25
HH001	Hammer Holder Leather	Oil-Tanned Split Leather	100

Measuring Tools

**NEW**



**TTL COMBINATION SQUARES**



Code	Item	Details	Inner	Outer
CS150	Combination Square	150mm	10	
GS300	Combination Square	300mm	10	80

**CH HANSON ASQUARE**



Code	Item	Details	Box Qty
ASQUARE345	345 A Square	3' x 4' x 5' Folding Layout Triangle	3



Code	Item	Details	Inner	Outer
JM316A	Measuring Counter Wheel	Carry Bag Included	1	4
MW318	Measuring Wheel Trigger Brake	Carry Bag Included, Extra Long Handle	1	5

**TTL TAPES AND RULERS**



Code	Item	Details	Inner	Outer
TTL001RMET	Standard Tape Measure	8m Metric Only, Red	12	48
TTL001YMET	Standard Tape Measure	8m Metric only, Yellow	12	48
TTL002MET/IM	Standard tape Measure	8m Metric/Imperial, Yellow	12	48
RL001MET	Extendable Ruler	1m Metric	12	120
RL002MET/IMF	Extendable Ruler	1m Metric/Imperial	12	120

**TTL RIVETERS**



Code	Item	Details	Box Qty
BT108	Hand Riveter	Standard	6

**TTL RIVETERS**



Code	Item	Details	Box Qty
BT201	Hand Riveter	Long Arm (Out of stock)	10
BT301	Hand Riveter	Scissor	10

**TTL GENERAL ITEMS**



Code	Item	Details	Box Qty
MB001	Mitre box	Locks for 10 Pre-set Cuts	4
BUC001	Tradie bucket 12L	<b>Minimum Order Qty 8</b>	<b>20</b>
DT001	Duct Tape 30m - silver	PVC Sealing and Joining	60
DTB001	Duct Tape 30m - black	PVC Sealing and Joining	<b>60</b>

**TTL GENERAL ITEMS**



Code	Item	Details	Box Qty
WS986	Drywall/Plaster Jab Saw	With Storage Pouch	10
GK001	Gun Kit 27 Pieces	<b>Gun Cleaning Kit</b>	<b>20</b>